



Parts Manual

Model: 1550-D

Covers Serial Number Range:

501-K-50TKZ8Y2-02501 through _____

Sold & Serviced By:

Contents

Quick Order List	1
Hopper and Plastic	3
Push Beam and Sight Gauge	5
Engine Compartment	7
Hood Assembly	9
Engine Assembly.....	13
Engine Cooling Assembly	15
Air Intake Assembly	17
Hydraulic Oil Tank	19
Fuel Tank	21
Wash Down Tank	23
Flight Chain Deck	25
Flight Chain Idler Components	27
Flight Chain Drive Components.....	29
Left Drive Track Assembly.....	31
Right Drive Track Assembly	33
Screed Arm Components	35
Main Screed Assembly	37
Upper Auger Assembly	39
Left Extension Assembly	41
Right Extension Assembly	43
Left End Gate Assembly	45
Right End Gate Assembly.....	47
Screed Heat Components.....	49
Electrical Schematic.....	53
Hydraulic Schematics	55

Quick Order List

No Exploded View Available

Quick Order List

BOM ID	Part Number	Description	Quantity
1	112-302080	Auger Bearing Support Assembly	4
2	015-0045	Auger Coupling Chain (Upper and Lower)	4
3	015-0154	Auger Sprocket (Upper and Lower)	4
4	092-0014	Auger, Lower (LH)	1
5	092-0013	Auger, Lower (RH)	1
6	112-200541	Auger, Upper (LH)	1
7	112-200540	Auger, Upper (RH)	1
8	050-0648	Cable, Steering	2
9	050-0347	Cable, Throttle	1
10	050-0522	Cap (Fuel Tank)	1
11	060-0069	Cap, Hydraulic Tank	1
12	050-0522	Cap (Wash Down Tank)	1
13	093-0121	Conveyor Chain	2
14	015-0258	Conveyor Chain Bar	24
15	015-0259	Conveyor Chain Rivet	48
16	024-0152	Decal Kit	1
17	021-0269	Filter Kit	1
17.1	021-0213	Filter, Air Main	1
17.2	021-0214	Filter, Air Pre-Cleaner	1
17.3	021-0215B	Filter, Engine Oil	1
17.4	021-0212B	Filter, Fuel	1
17.5	021-0169	Filter, Hydraulic Oil	2
18	093-408756	Plastic, Hopper Outer	2
19	093-408620	Plastic, Hopper Inner	2
20	093-408622	Plastic, Front Center	1
21	093-408838	Plastic, Hopper Scraper	2
22	091-100776	Push Roller	2
23	112-109290	Screed Burner Assembly	2
24	020-0562	Ignitor Propane Burner	4
25	090-0231	Screed Lighting Torch Assembly	1
26	111-200008	Screed Plate	1
27	111-209030	Extension Wear Plate	2
28	050-0361	Spray Nozzle	2
29	015-0275A	Sprocket, Drive	2
30	015-0288A	Optional Hardened Cast Lower Auger Assy RH	1
31	015-0289A	Optional Hardened Cast Lower Auger Assy LH	1
32	015-0286	Optional Hardened Cast Auger Coupler	2

Hopper and Plastic

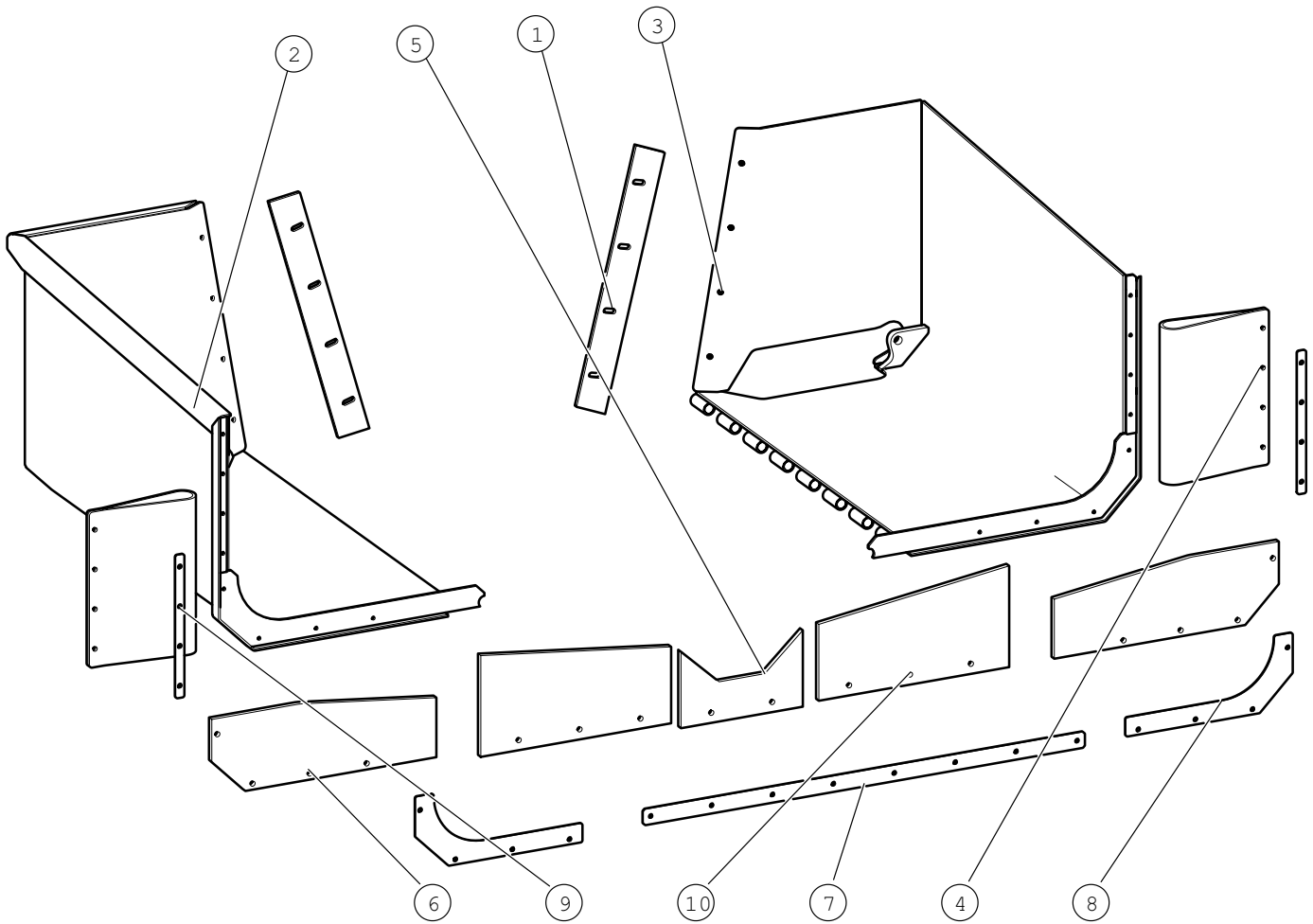

Plastic and Hopper

BOM ID	Part Number	Description	Qty
1	093-408838	HOPPER REAR PLASTIC WIPER	2
2	092-204400	HOPPER WELDMENT RH	1
3	092-204401	HOPPER WELDMENT LH	1
4	093-408756	HOPPER SIDE FLAPS	2
5	093-408621	HOPPER PLASTIC CENTER W/ CUTOUT	1
6	093-408758	HOPPER FRONT SIDE PLASTIC	2
7	093-100748	RETAINER BAR HOPPER PLASTIC	1
8	093-408832	RETAINER HOPPER PLASTIC	2
9	093-408830	RETAINER BAR HOPPER RUBBER	2
10	093-408620	HOPPER PLASTIC FRONT SIDES	2

Push Beam and Sight Gauge

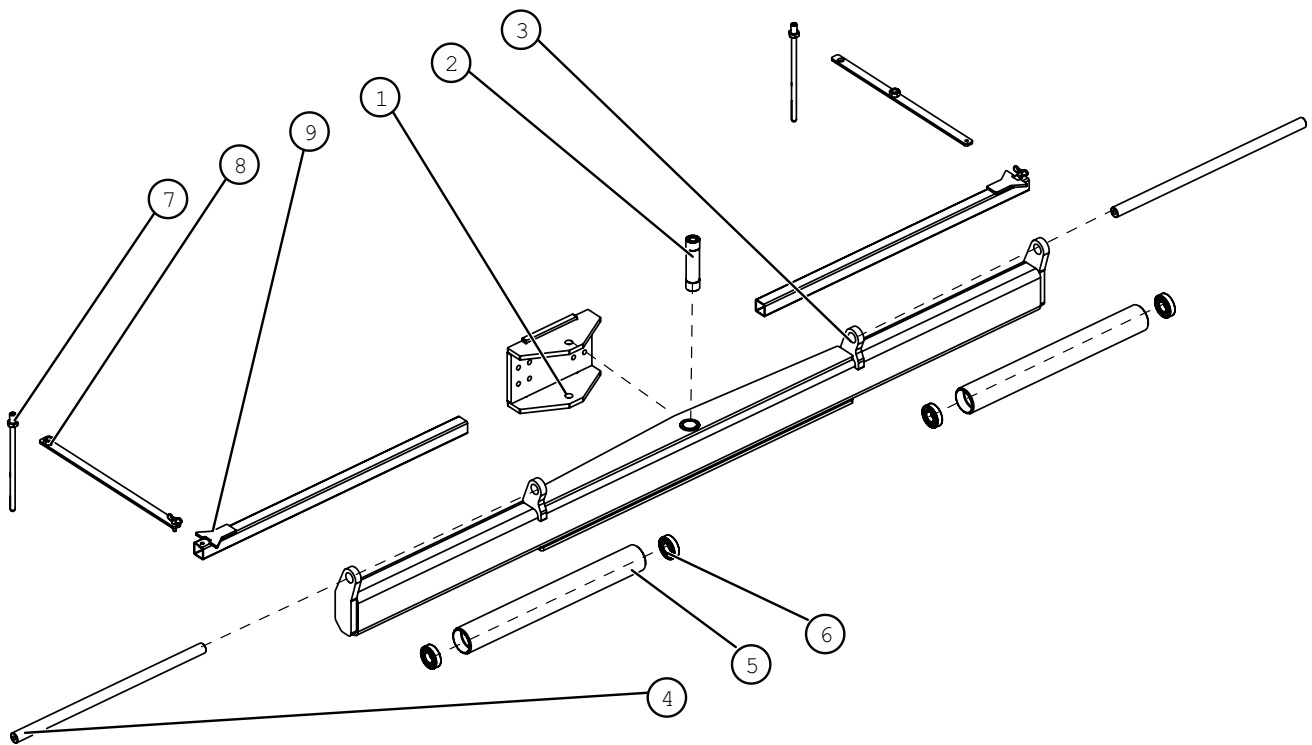

Push Beam and Sight Gauge

BOM ID	Part Number	Description	Quantity
1	092-408574	Push Beam Bracket	1
2	091-104306	Push Beam Pivot Bushing	1
3	092-100512	Push Beam Weldment	1
4	091-100778	Push Roller Shaft	2
5	091-100776	Push Roller Assembly	2
6	018-0010	Push Roller Replacement Bearing	4
7	093-204632	Sight Gauge Rod	2
8	093-204628	Guide Arm Sight Gauge	2
9	093-204634	Sight Gauge Ext Tube	2

Engine Compartment

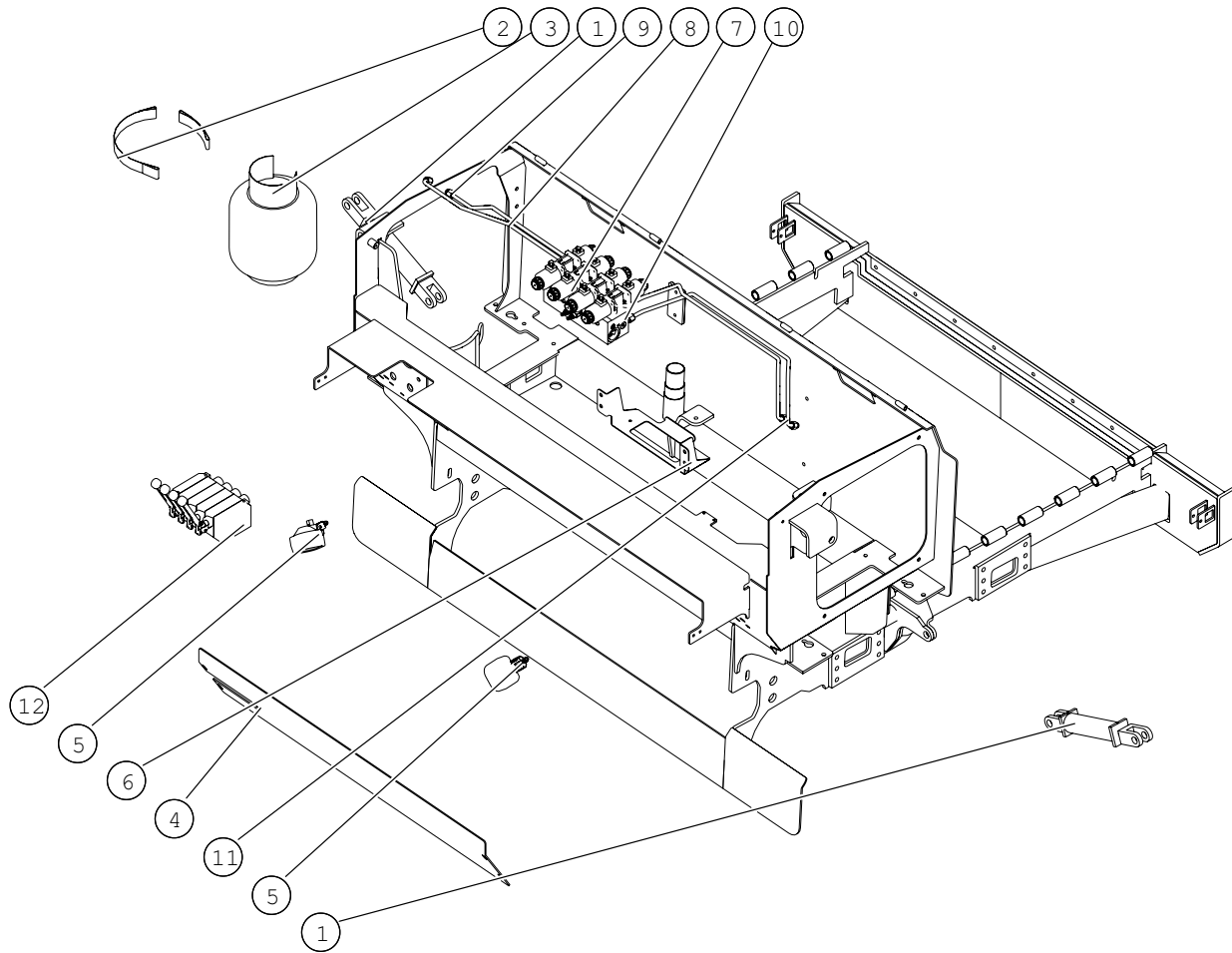

Engine Compartment

BOM ID	Part Number	Description	Quantity
1	012-0051	Hopper Cylinder	2
2	050-0649	Strap Propane Tank	1
3	050-0039	Propane Tank	1
4	093-204054	Engine Compartment Access Panel	1
5	020-0675	Work Lights	2
6	092-204102	Battery Bracket	1
7	017-0155	5 Station Valve Manifold	1
8	014-204000	Tube Hydraulic A2 to Left Outside	1
9	014-204001	Tube Hydraulic B2 to Left Inside	1
10	014-204002	Tube Hydraulic A4 to Right Outside	1
11	014-204003	Tube Hydraulic B4 to Right Inside	1
12	017-0193	4 Section Valve Bank	1

Hood Assembly

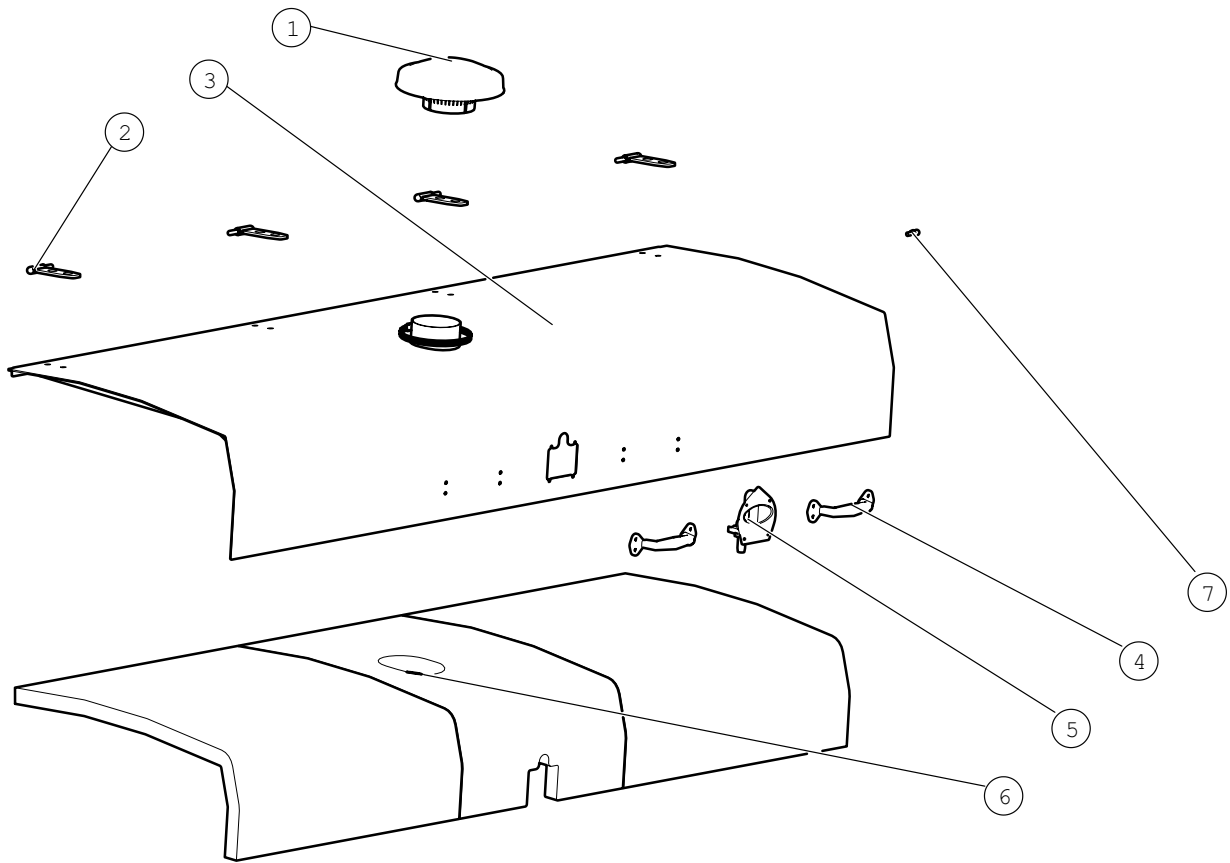

Hood Assembly

BOM ID	Part Number	Description	Quantity
1	050-0814	4.5" RAIN CAP	1
2	092-204086	HINGE	4
3	092-204080	WELDMENT HOOD	1
4	050-0205	GRAB HANDLE	2
5	050-0660	LOCKING HANDLE	1
6	027-204081	INSULATION	1
7	050-0659	MOUNTING BALL STUD	2

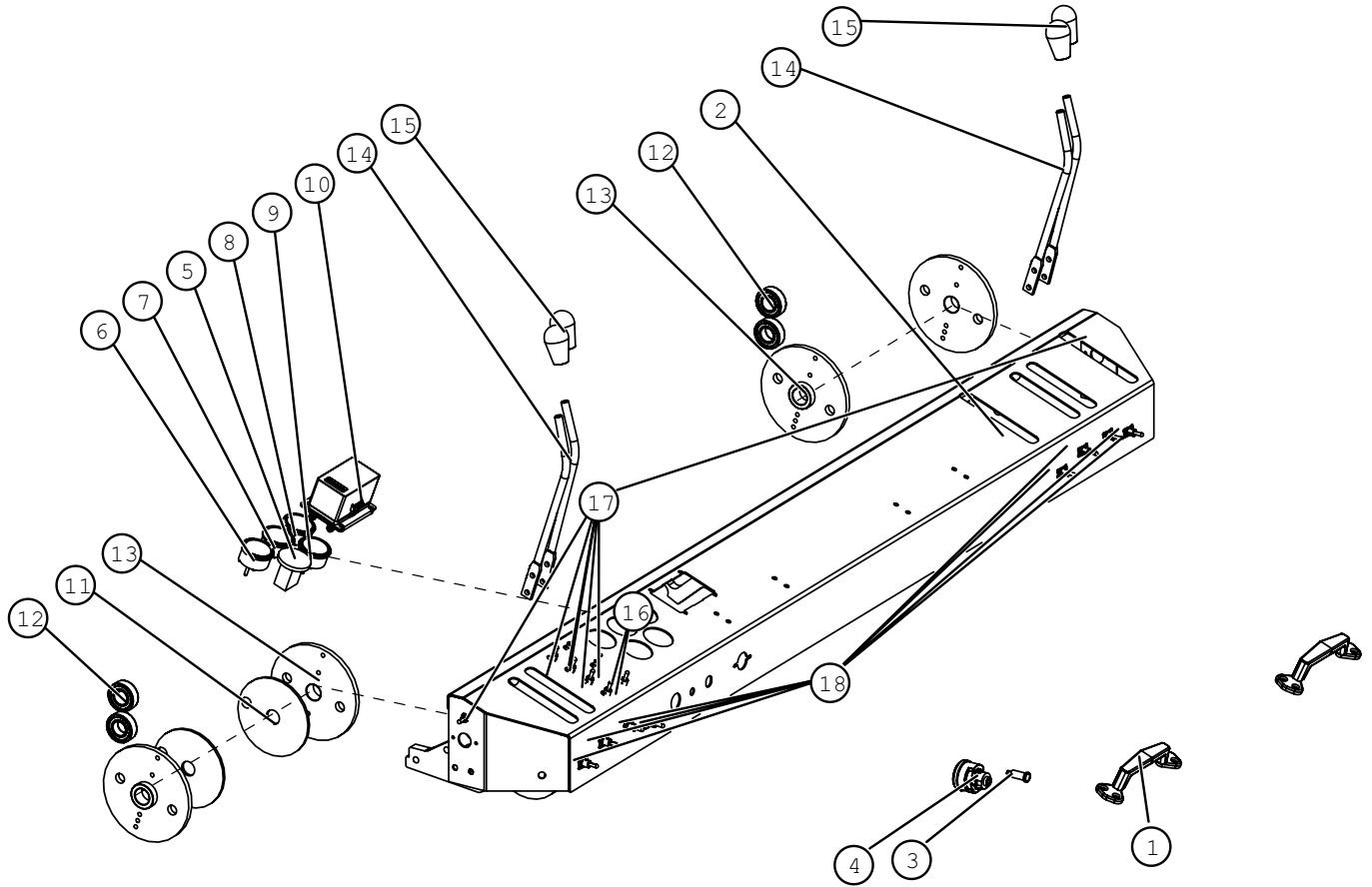

BOM ID	Part Number	Description	Quantity
1	050-0205	Grab Handle	2
2	092-204400	Dash Weldment	1
3	020-0140	Indicator Light	1
4	020-0156	Key Switch	1
5	020-0173	Gauge Hour Meter	1
6	020-0169	Gauge Volt Meter	1
7	020-0171	Gauge Oil Pressure	1
8	020-0172	Gauge Coolant Temperature	1
9	020-0170	Gauge Fuel Level	1
10	020-0476	Box Fuse and Relay	1
11	015-0229	Plastic Disc	2
12	018-0011	Bearing	4
13	093-100074	Aluminum Gear	4
14	093-0318	Steering Lever	4
15	050-0388	Steering Knob	4
16	020-0423	Switch (Horn, Reverse Conveyor)	2
17	020-0405	Switch On/Off	7
18	020-0083	Switch Auger and Conveyor Controls	8
(Not Shown)	050-0648	Cable Drive	2
(Not Shown)	050-0347	Throttle Cable	1
(Not Shown)	050-0372	Connector Auto Auger	2
(Not Shown)	020-0480	Circuit Breaker 20amp	10
(Not Shown)	020-0481	Relay 12v 5 Terminal	2

Engine Assembly

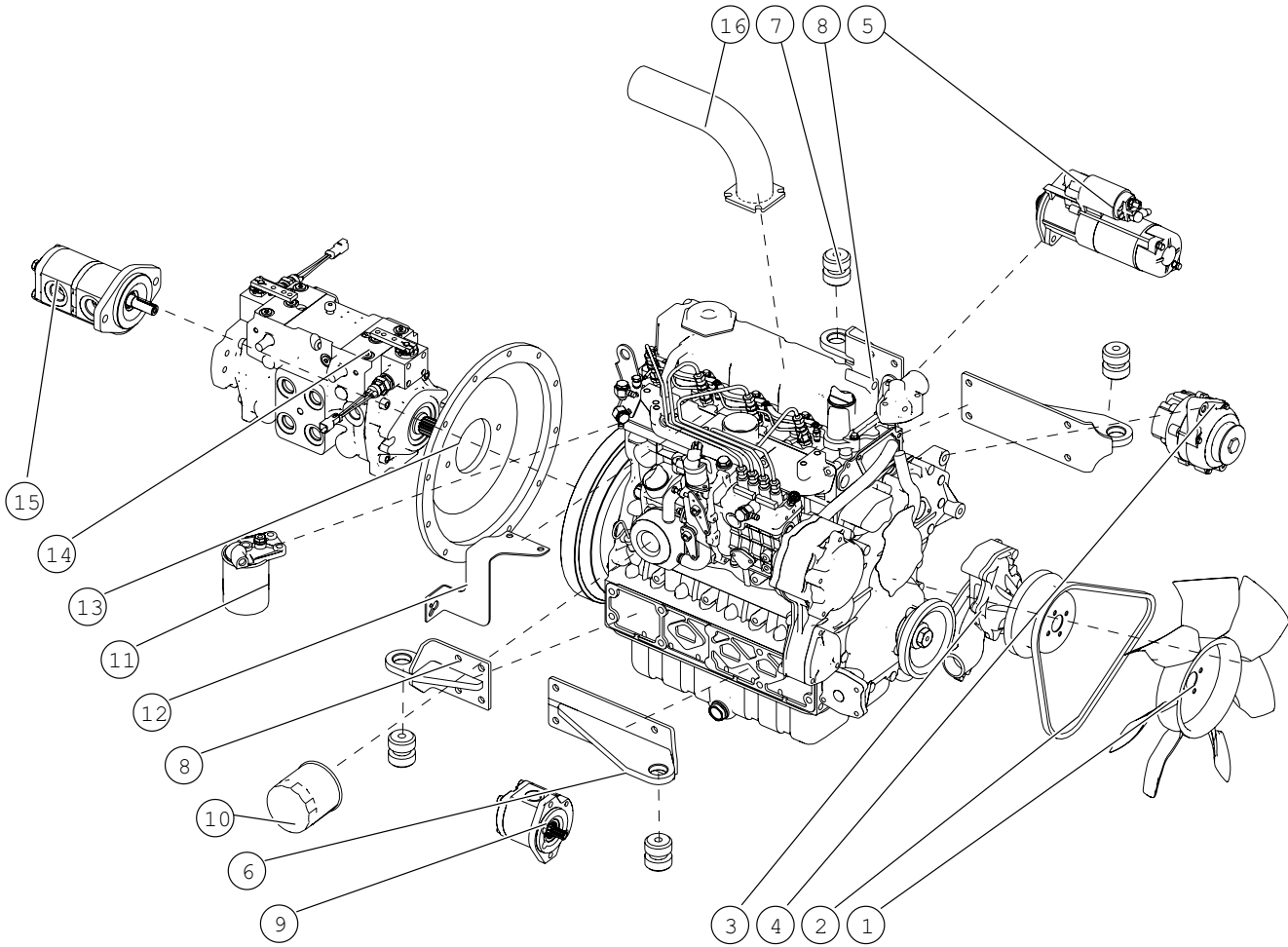

Engine Assembly

BOM ID	Part Number	Description	Quantity
1	010-0684	Fan Blade	1
2	010-0737	Serpentine Belt	1
3	010-0771	Water Pump	1
4	010-0704	Alternator	1
5	010-0702	Starter	1
6	092-204170	Engine Mount Bracket Long	2
7	050-0260	Engine Mount Rubber Isolator	4
8	092-204030	Engine Mount Short	2
9	011-0152B	Auxiliary Pump	1
10	021-0215B	Filter Oil	1
11	021-0212B	Filter Fuel	1
12	093-109046	Throttle Cable Bracket	1
13	010-04981	Plate Pump Mount Assy (includes coupling plate)	1
14	011-0268	Tandem Drive Pump	1
15	011-0269	Tandem Pump	1
16	092-109150	Exhaust Pipe	1
(Not Shown)	020-0304	Sending Unit Oil Pressure	1
(Not Shown)	020-0178	Sending Unit Coolant Temp	1

Engine Cooling Assembly

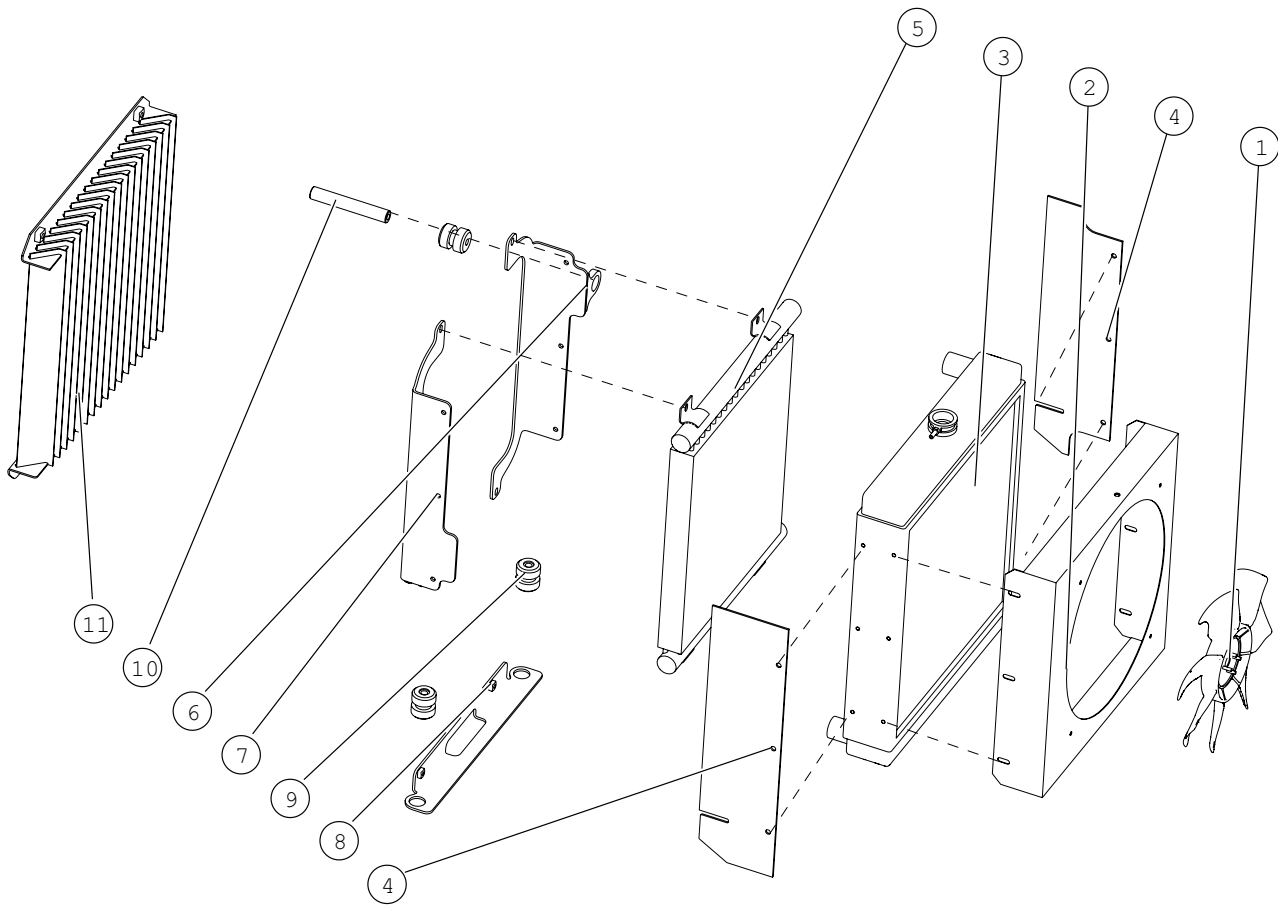

Engine Cooling Assembly

BOM ID	Part Number	Description	Quantity
1	010-0684	Fan	1
2	010-06841	Fan Shroud	1
3	010-0458B	Radiator	1
4	015-0255	Radiator Baffle	2
5	050-0181	Hydraulic Oil Cooler	1
6	092-109130	Forward Radiator Mount	1
7	093-109130	Rear Radiator Mount	1
8	092-109132	Lower Radiator Mount	1
9	050-0260	Rubber Isolator	3
10	093-204136	Radiator Shaft Mount	1
11	092-202100	Louver	1

Air Intake Assembly

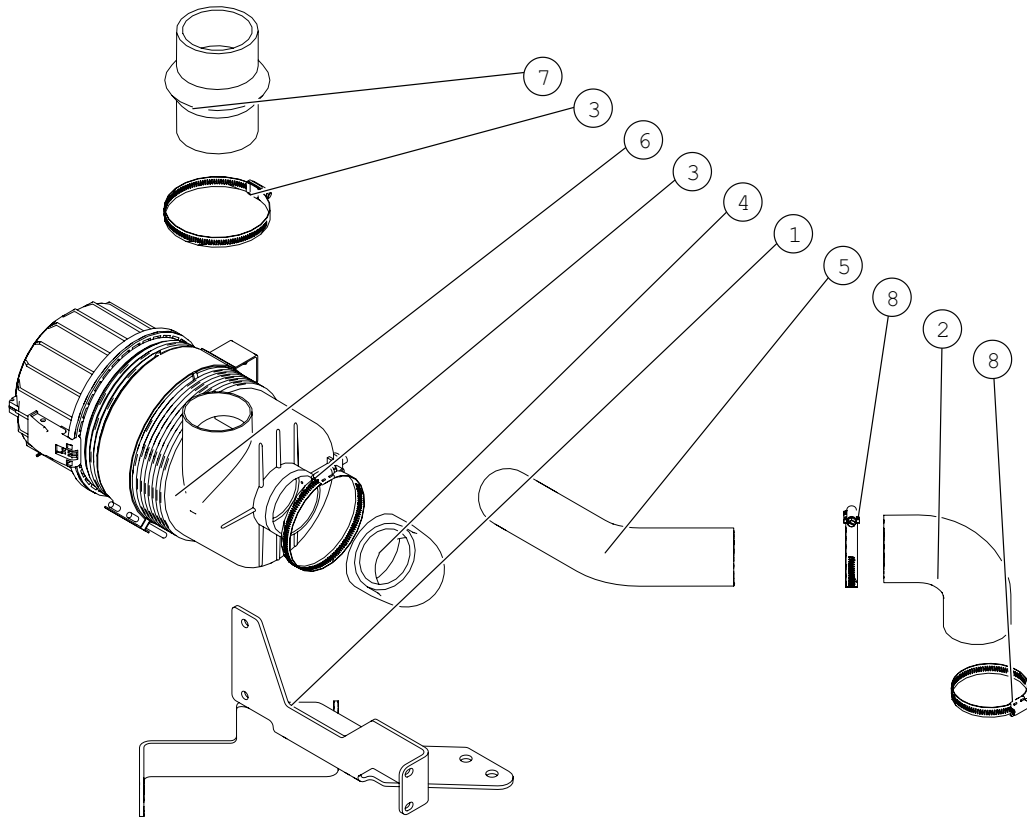

Air Intake Assembly

BOM ID	Part Number	Description	Quantity
1	093-204104	Air Cleaner Bracket	1
2	050-0633	Engine Intake Rubber Elbo	1
3	015-0227	Hose Clamp	2
4	050-0494	Air Box Rubber Elbo Reducer	1
5	050-0495	Intake Pipe	1
6	050-0638	Air Box Assembly	1
7	050-0813	Coupler Air Box to Hood	1
8	050-0360	Hose Clamp	2
(Not Shown)	021-0213	Filter Main Air	1
(Not Shown)	021-0214	Filter Precleaner Air	1

Hydraulic Oil Tank

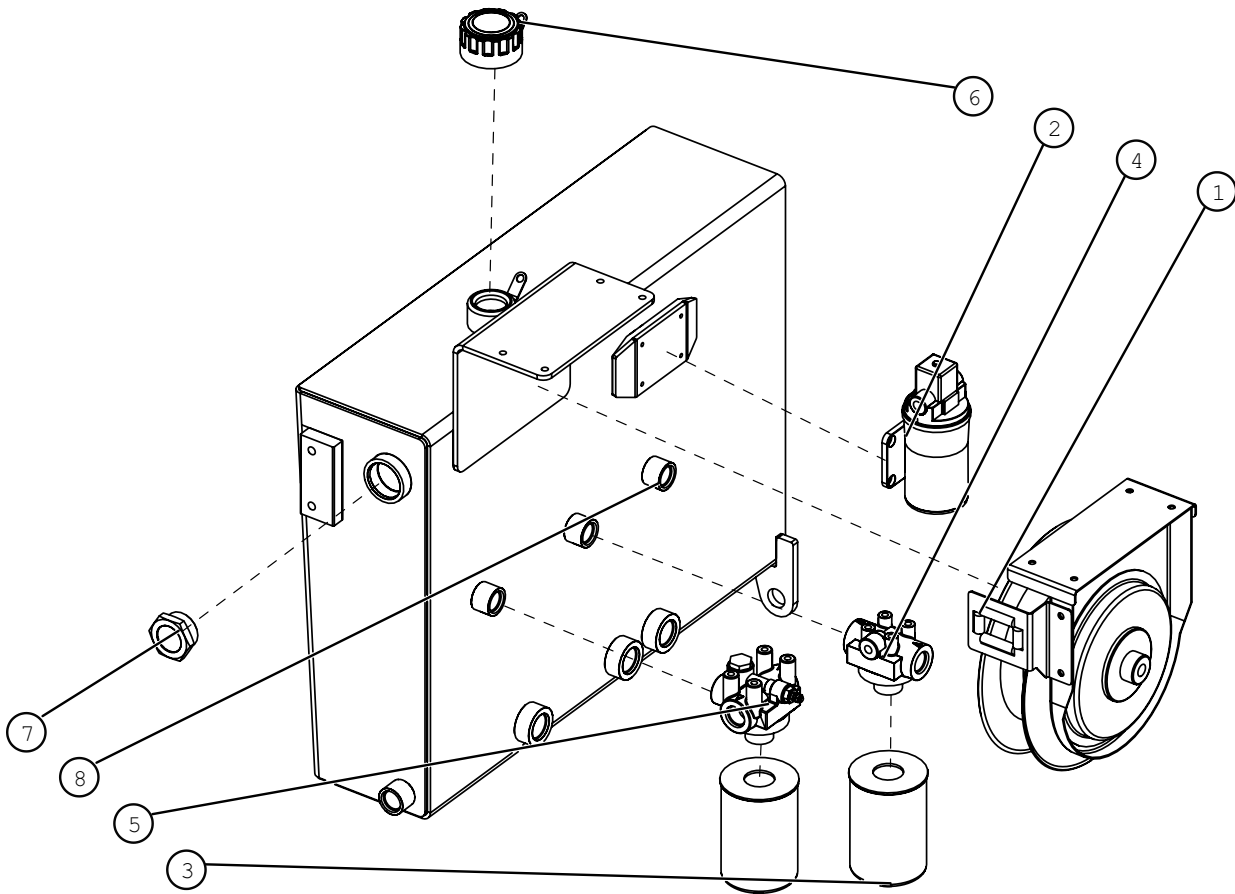

Hydraulic Oil Tank

BOM ID	Part Number	Description	Quantity
1	050-0344	Hose Reel Wash Down	1
2	011-0231	Pump Wash Down	1
3	021-0169	Filter Hydraulic	2
4	021-0192	Hydraulic Filter Head	1
5	021-0233	Filter Head	1
6	060-0069	Hydraulic Cap Locking	1
7	060-0066	Sight Gauge	1
8	092-204126	Hydraulic Tank Weldment	1

Fuel Tank

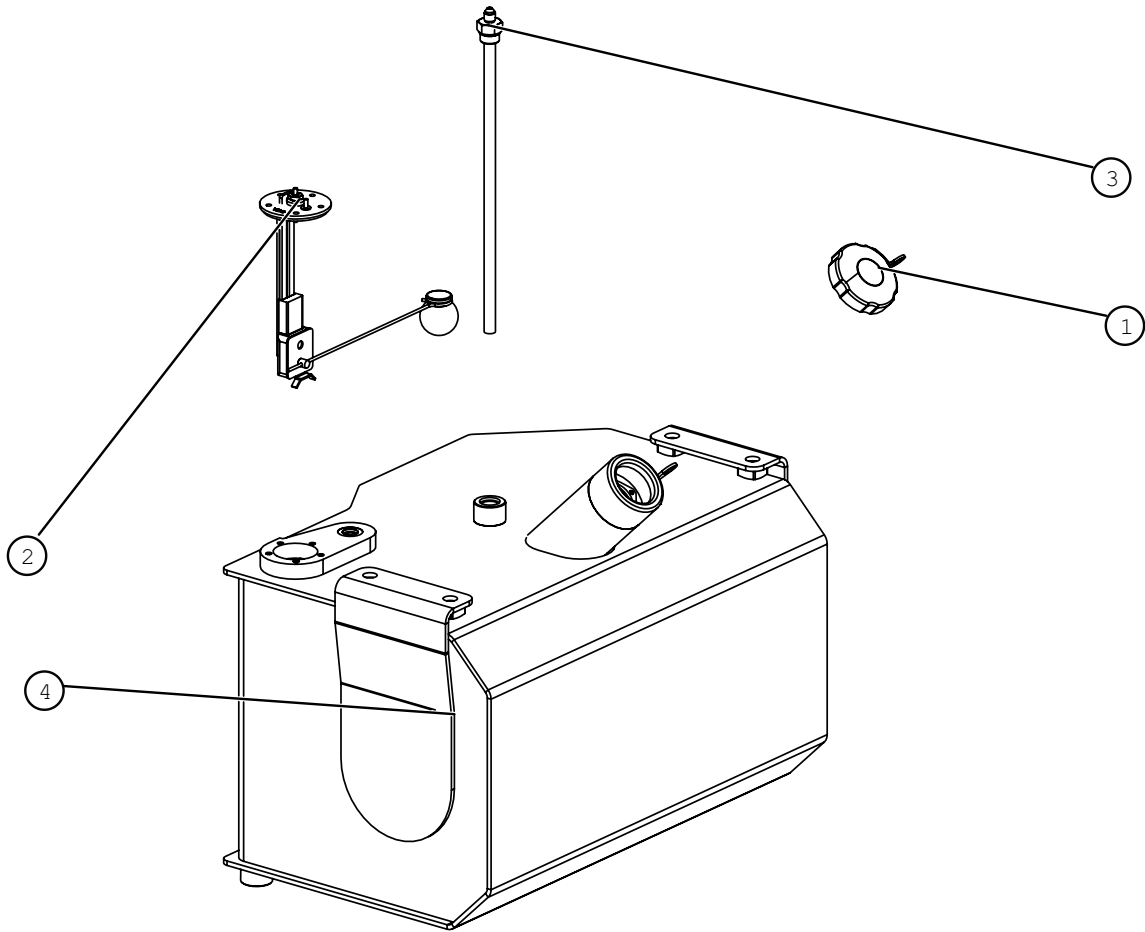

Fuel Tank

BOM ID	Part Number	Description	Quantity
1	050-0522	Cap Fuel Locking	1
2	020-0174	Sender Fuel	1
3	092-202300	Fuel Pick up Tube	1
4	092-204116	Fuel Tank Weldment	1

Wash Down Tank

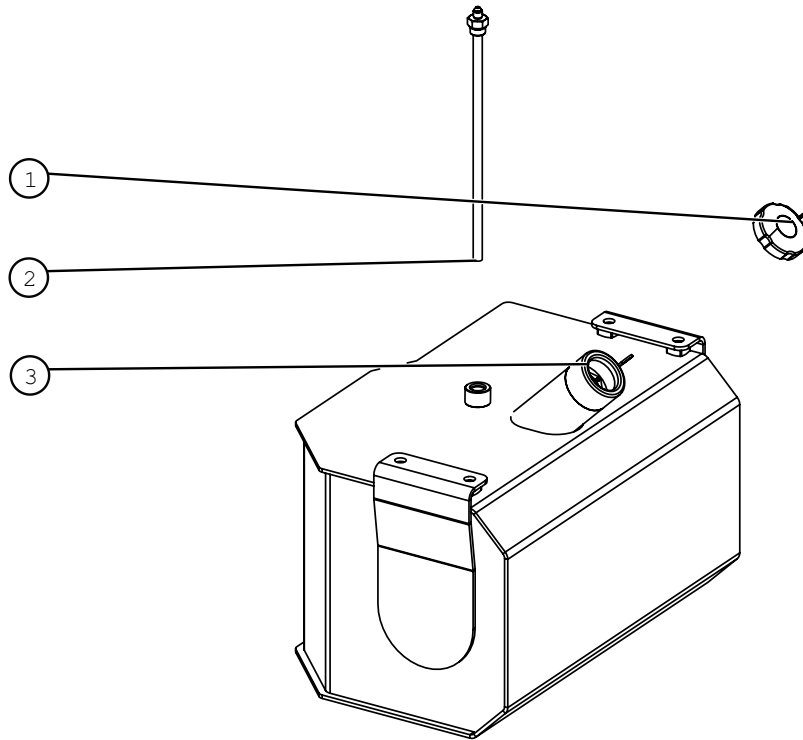

Wash Down Tank

BOM ID	Part Number	Description	Quantity
1	050-0522	Cap Wash Down Locking	1
2	092-202300	Wash Down Pick up Tube	1
3	092-204116	Wash Down Tank	1

Flight Chain Deck

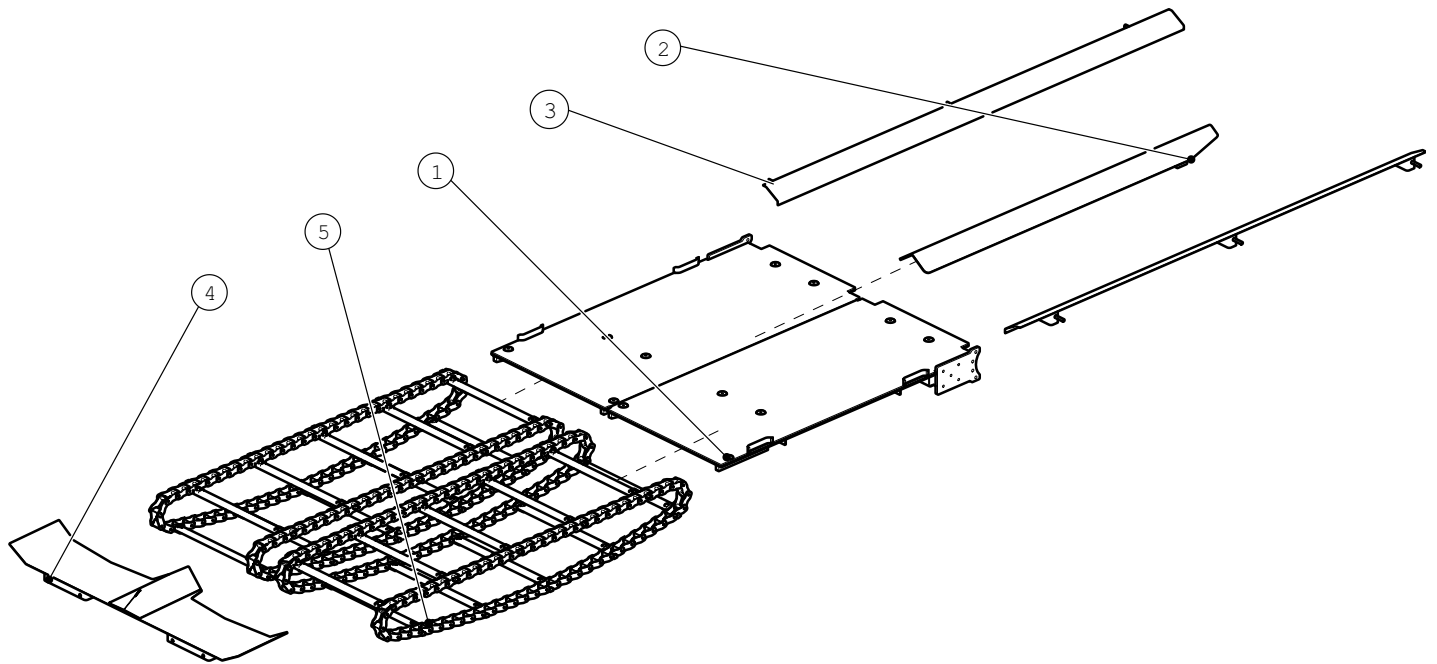

Flight Chain Deck

BOM ID	Part Number	Description	Quantity
1	092-214200	Flight Chain Deck	1
2	092-214230	Center Cover Flight Chain	1
3	092-214219	Left Hand Wear Plate	1
4	092-214218	Right Hand Wear Plate	1
5	093-0121	Flight Chain Assembly	2
6	092-214210	Cover Front Conveyor	1
7	092-100133	Cover Conveyor Sides	2

Flight Chain Idler Components

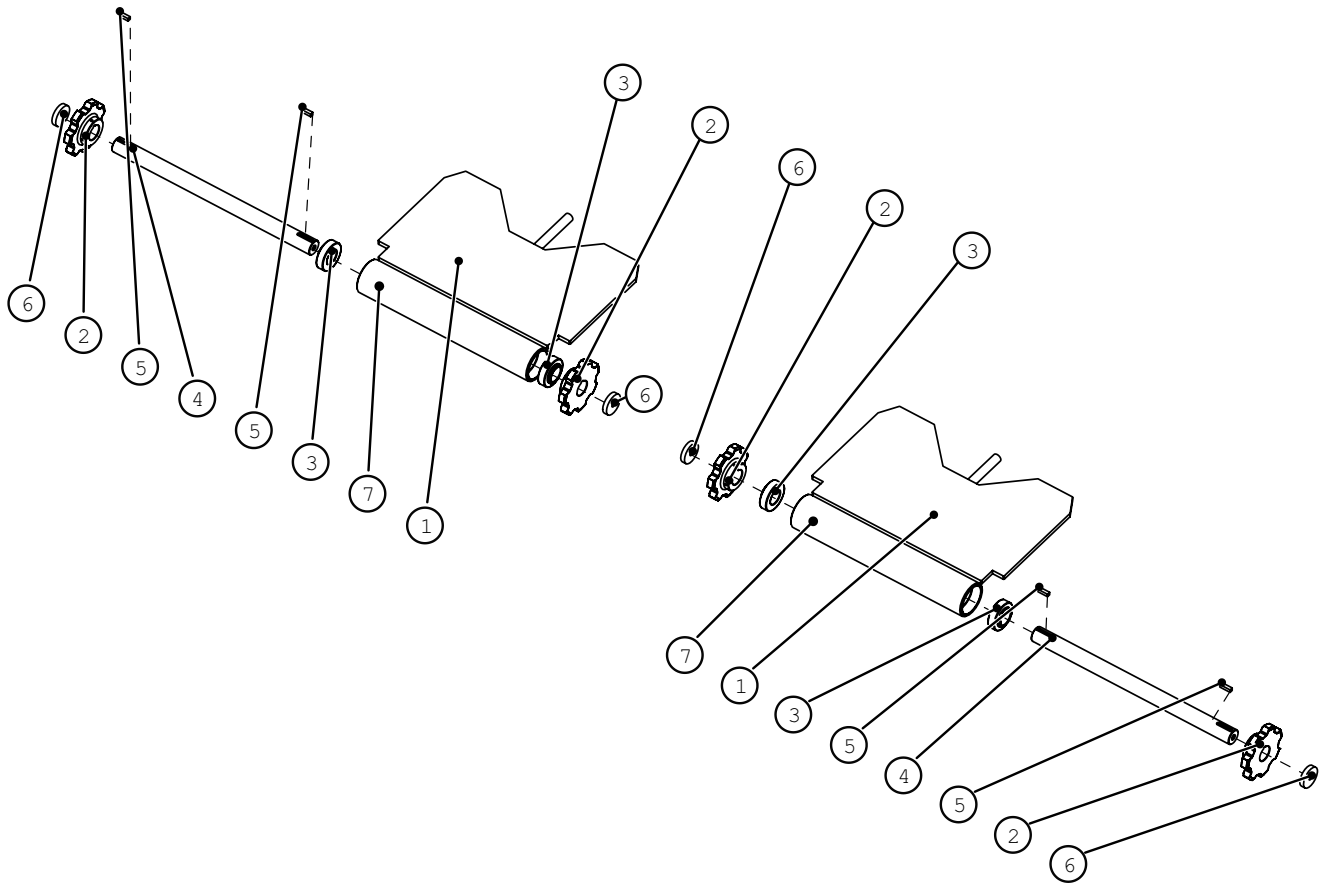

Flight Chain Idler Components

BOM ID	Part Number	Description	Quantity
1	092-214220	Weldment Flight Chain Adjusting Plate	2
2	015-0204	Sprocket 7 tooth	4
3	018-0091	Bearing Flight Chain Tube	4
4	093-0332	Shaft Flight Chain Idler	2
5	093-0335	Key way .375in x 1.750in	4
6	093-0339	Cap Spacer Flight Chain	4
7	093-0334	Flight Chain Tube	2

Flight Chain Drive Components

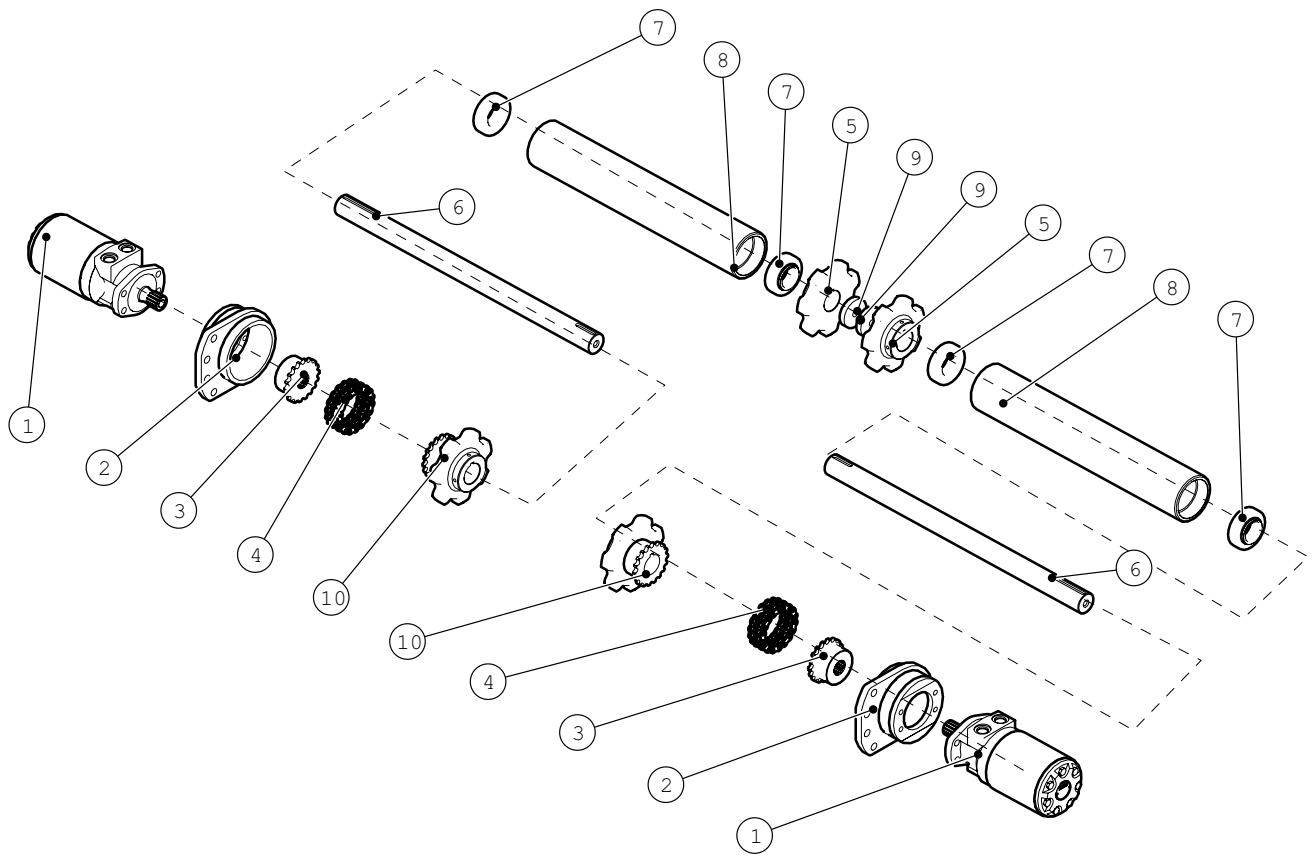

Flight Chain Drive Components

BOM ID	Part Number	Description	Quantity
1	013-0068	Flight Chain Hydraulic Motor	2
2	092-204260	Flight Chain Motor Mount	2
3	015-0202	Coupling 5018F 1.75in	2
4	015-0046	Chain Coupling	2
5	015-0204	Sprocket 7 tooth Flight Chain	2
6	093-0332	Flight Chain Drive Shafts	2
7	018-0091	Flight Chain Bearings	4
8	093-0334	Flight Chain Tube	2
9	093-0339	Spacer End Cap	2
10	092-109254	Sprocket Drive Flight Chain	2

Left Drive Track Assembly

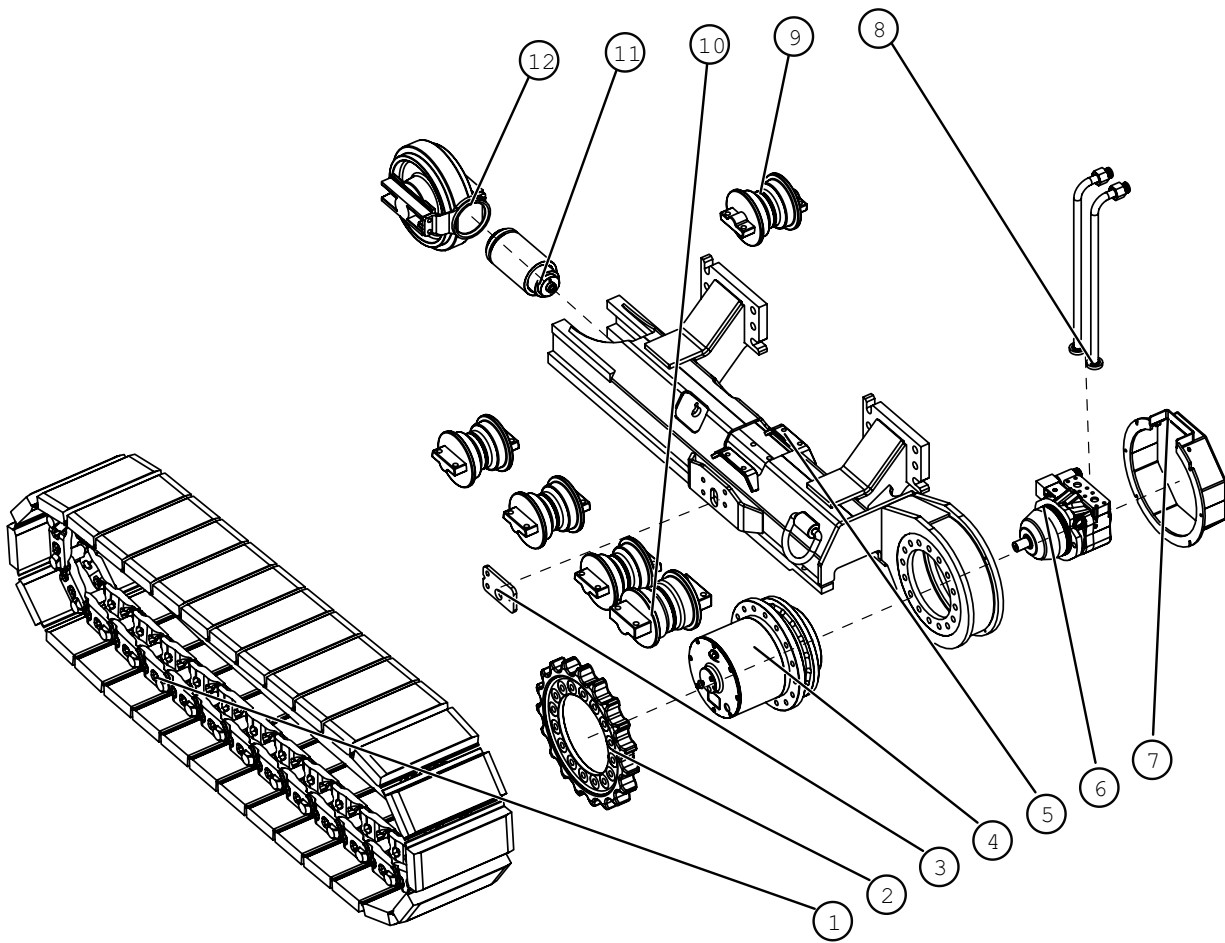

Left Drive Track Assembly

BOM ID	Part Number	Description	Quantity
1	050-0626EX	Track Chain Assembly	1
2	015-0275A	Drive Sprocket	1
3	093-204550	Screed Arm Mount Plate	1
4	016-0058	Planetary	1
5	092-204501	Undercarriage Weldment LH	1
6	011-0263	Drive Motor	1
7	092-204570	Drive Motor Cover	1
8	014-0635	Drive Motor Hydraulic Tube	2
9	050-0257	Track Roller Small	4
10	050-0163	Track Roller Large	1
11	012-0060	Track Tension Cylinder	1
12	050-0624	Track Idler	1
(Not Shown)	050-0664EX	Track Pad (Individual)	30
(Not Shown)	015-0276	Track Connecting Pin	1
(Not Shown)	030-0500	Bolt Track Pad	120
(Not Shown)	030-0501	Nut Track Pad	120

Right Drive Track Assembly

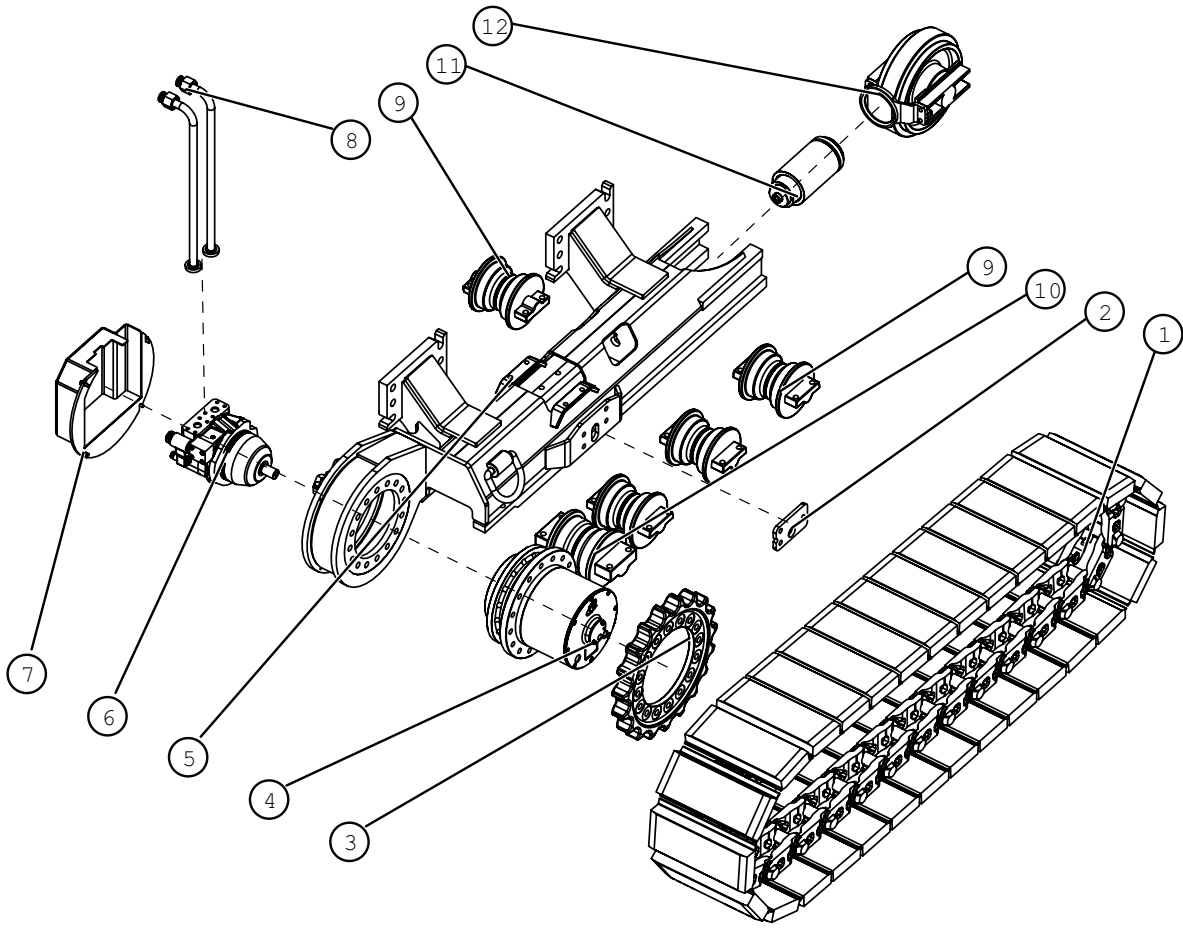

Right Drive Track Assembly

BOM ID	Part Number	Description	Quantity
1	050-0626EX	Track Chain Assembly	1
2	093-204550	Tow Arm Mounting Plate	1
3	015-0275A	Drive Sprocket	1
4	016-0058	Planetary	1
5	092-204500	Undercarriage Weldment RH	1
6	011-0263	Drive Motor	1
7	092-204570	Drive Motor Cover	1
8	014-0635	Drive Motor Hydraulic Tube	2
9	050-0257	Track Roller Small	4
10	050-0163	Track Roller Large	1
11	012-0060	Track Tension Cylinder	1
12	050-0624	Track Tension Idler	1
(Not Shown)	050-0664EX	Track Pad (Individual)	30
(Not Shown)	015-0276	Track Connecting Pin	1
(Not Shown)	030-0500	Bolt Track Pad	120
(Not Shown)	030-0501	Nut Track Pad	120

Screed Arm Components

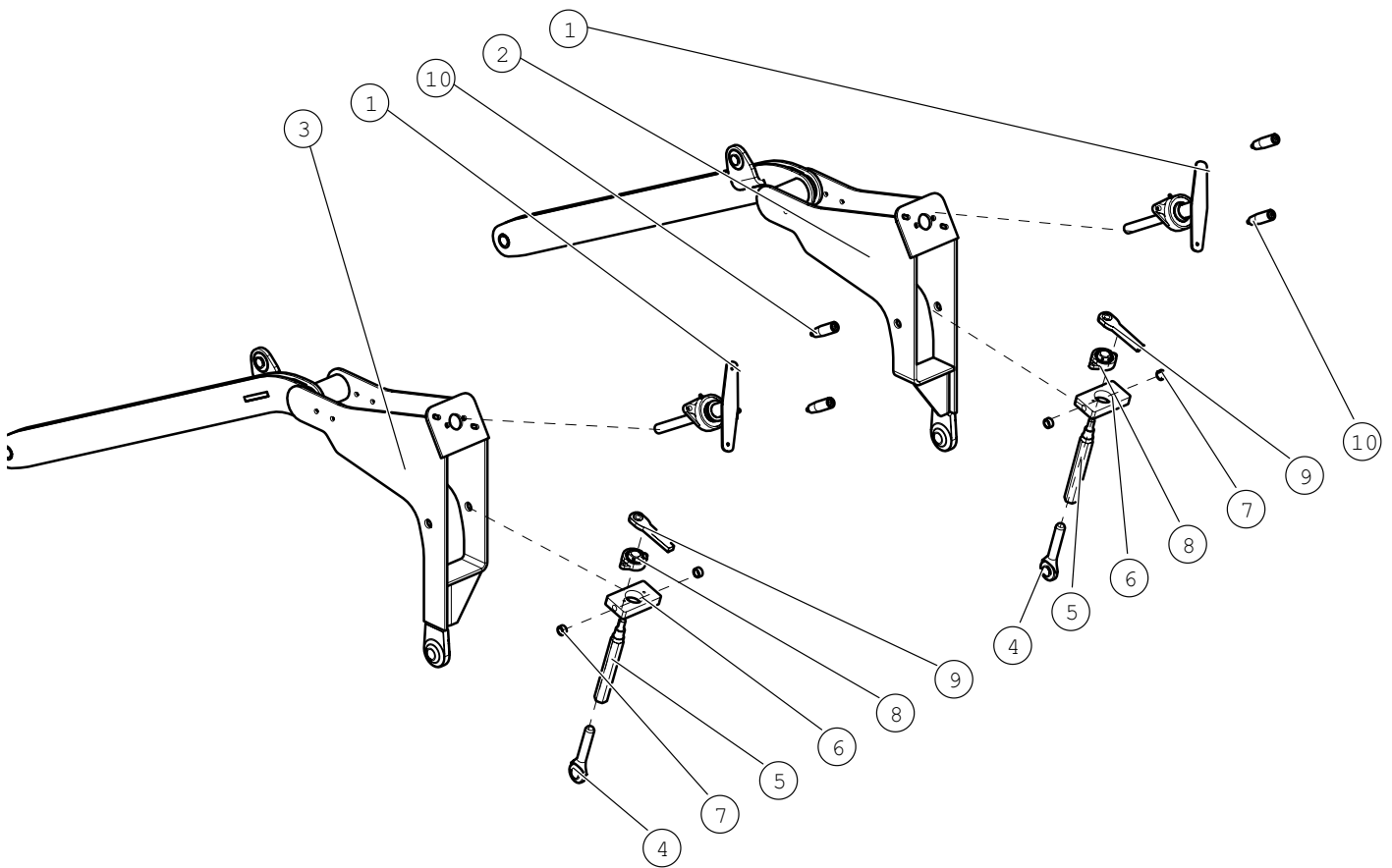

Screed Arm Components

BOM ID	Part Number	Description	Qty
1	111-209070	Screed Depth Handle	2
2	112-209552	Screed Arm RH	1
3	112-209553	Screed Arm LH	1
4	112-209582	Extension Height Adjustment Threaded	2
5	113-209182	Extension Height Hex Rod	2
6	113-209180	Extension Height Block	2
7	113-209184	Spacer	4
8	018-0027	Extension Height Bearing	2
9	111-104170	Handle Ratcheting	2
10	113-100427	Handle	4
(Not Shown)	012-0065	Screed Lift Hydraulic Cylinder	2

Main Screed Assembly

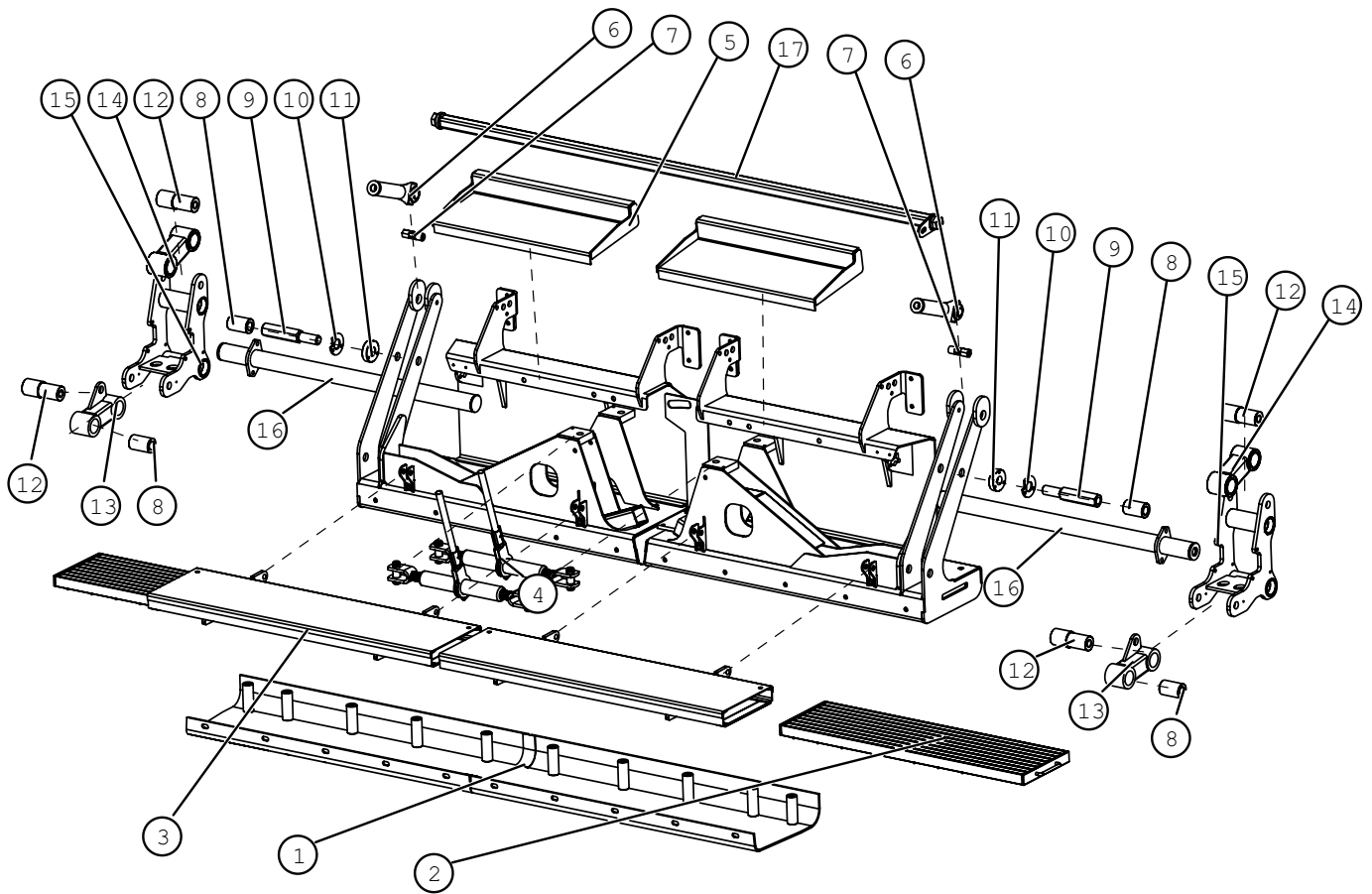

Main Screed Assembly

BOM ID	Part Number	Description	Quantity
1	111-200008	Screed Bottom	1
2	111-100701	Walk Board Extensions	2
3	112-209101	Lower Walk Board	2
4	050-0147B	Ratchet Jack	2
5	112-200520	Upper Walk Board	2
6	111-209400	Screed Depth Handle Receiver	2
7	113-209404	Screed Depth Receiver Pin	2
8	113-209150	Bushing	4
9	113-209080	Tower Adjusting Bolt	2
10	113-209084	Tower Adjusting Plate	2
11	113-209656	Nut Tower Adjusting	2
12	113-209152	Pivot Rod	4
13	111-209140	Match Height Link	2
14	111-209142	Linke Slope	2
15	111-209012	Screed Tower Link	2
16	012-0069	Extension Hydraulic Cylinder	2
17	112-209430	Screed Stabilizer	1
(Not Shown)	020-0667	Vibrator Electric	1

Upper Auger Assembly

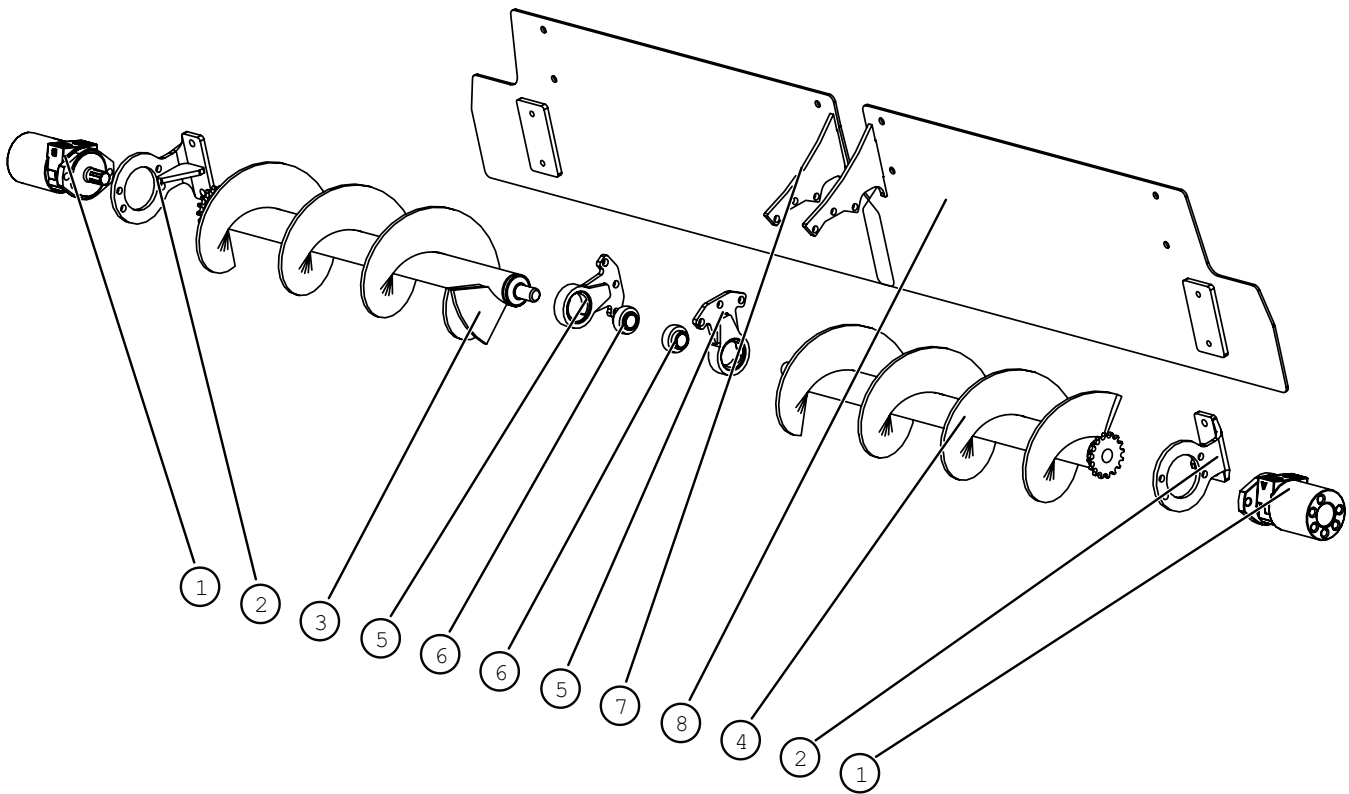

Upper Auger Assembly

BOM ID	Part Number	Description	Quantity
1	013-0096	Auger Motor	2
2	111-200072	Auger Mounting Bracket	2
3	112-200540	Upper Auger RH	1
4	112-200541	Upper Auger LH	1
5	112-302080	Auger Support Assembly	2
6	018-0105	Bearing Replacement	2
7	112-200502	Auger Mounting Plate RH	1
8	112-200503	Auger Mounting Plate LH	1
9 (not shown)	015-0154	Auger Sprocket	2
10 (not shown)	015-0045	Auger Chain Coupler	2

Left Extension Assembly

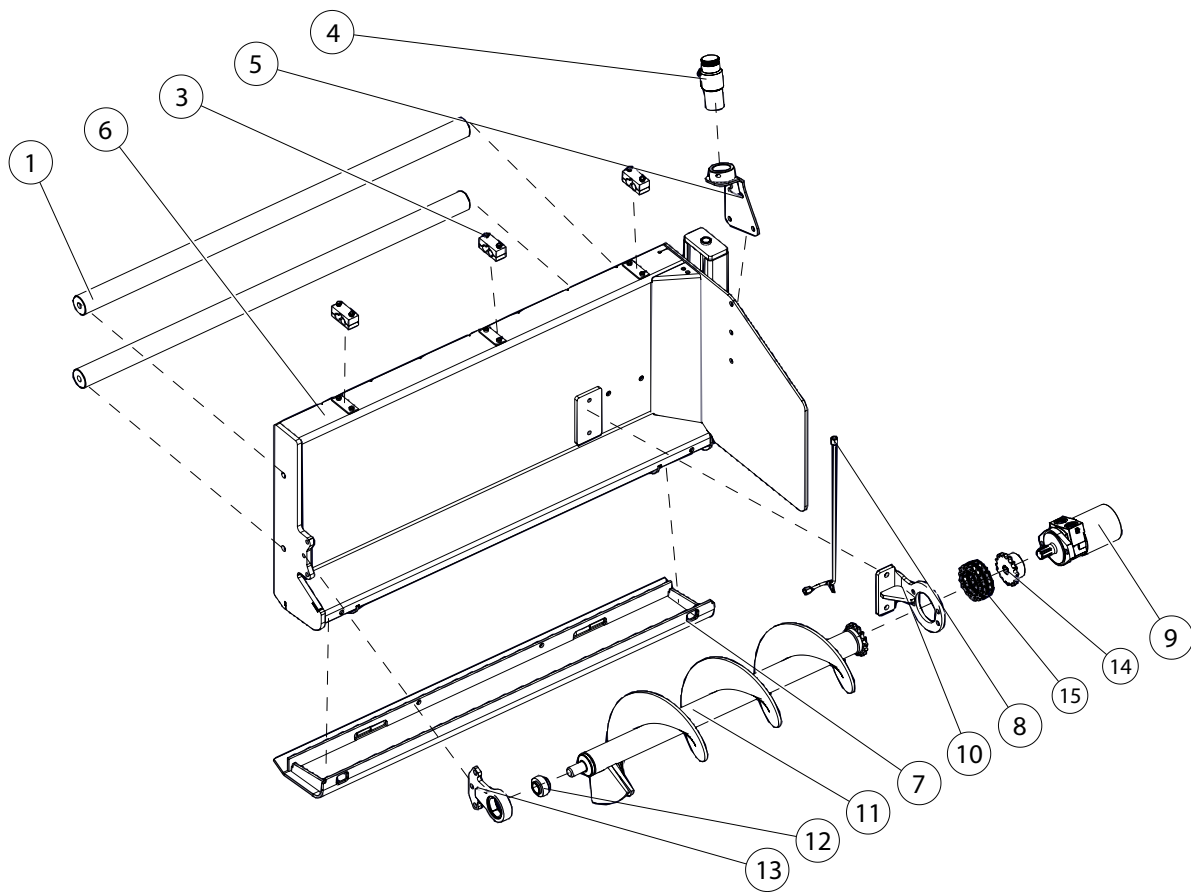

Left Extension Assembly

BOM ID	Part Number	Description	Quantity
1	113-209169	Extension Guide Rod	2
3	050-0415	Hose Clamp	3
4	050-0790	Sonic Sensor	1
5	112-200090	Sonic Sensor Mount	1
6	112-209515	Extension Weldment LH	1
7	111-209830	Extension Wear Plate	1
8	113-200046	Propane Tube	1
9	013-0096	Auger Motor	1
10	112-200072	Auger Motor Mount	1
11	092-0014	Auger Assembly LH	1
12	018-0105	Auger Bearing (bearing replacement)	1
13	112-302080	Auger Hanger Assembly (includes bearing)	1
14	015-0154	Sprocket	1
15	015-0045	Chain Coupler Auger	
(Not Shown)	050-0350	Electrical Cord Auger Sensor	1

Right Extension Assembly

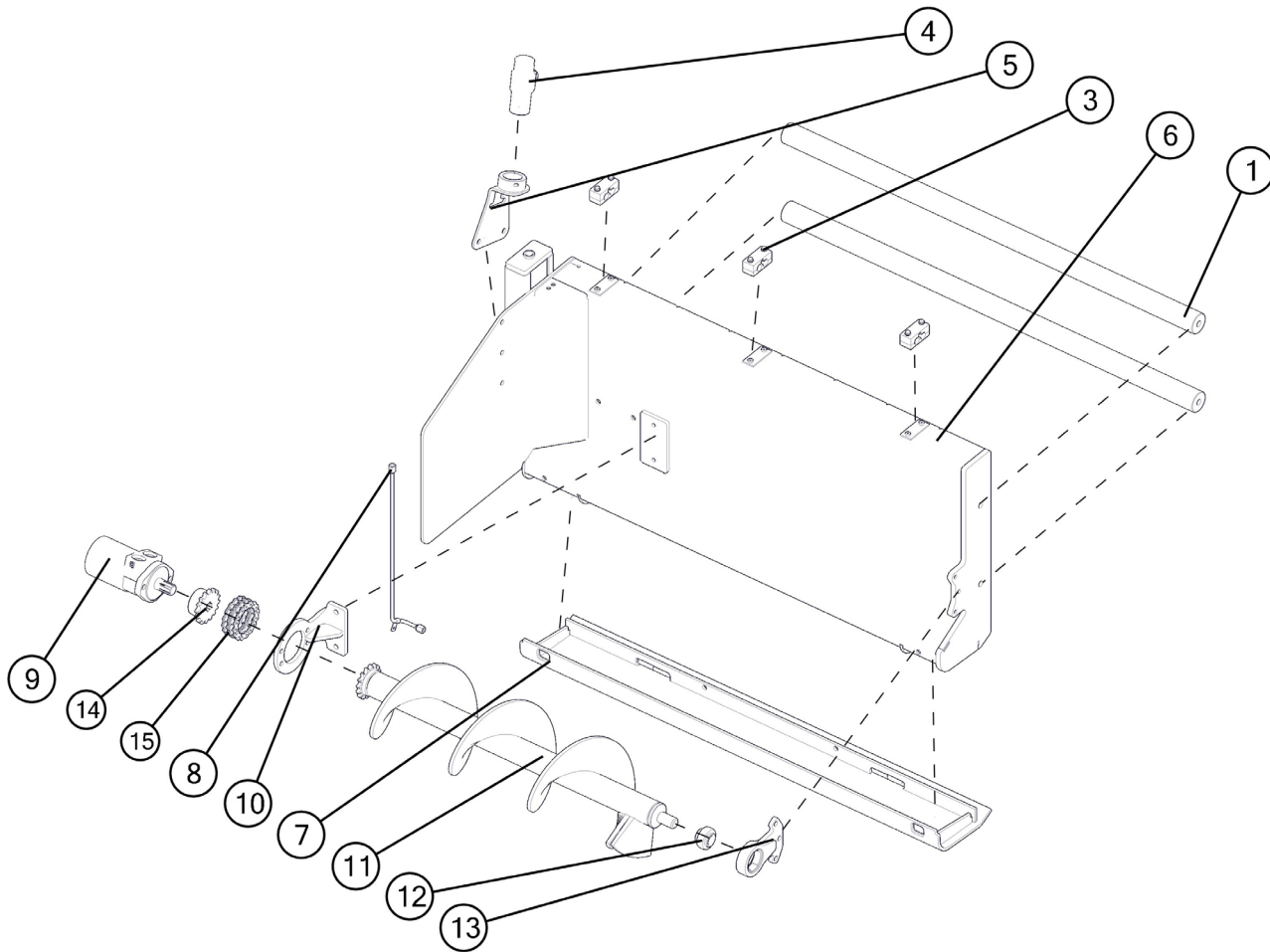

Right Extension Assembly

BOM ID	Part Number	Description	Quantity
1	113-209169	Extension Guide Rod	2
3	050-0415	Hose Clamp	3
4	050-0790	Sonic Sensor	1
5	112-200090	Sonic Sensor Mount	1
6	112-209514	Extension Weldment RH	1
7	111-209830	Extension Wear Plate	1
8	113-200046	Propane Tube	1
9	013-0096	Auger Motor	1
10	112-200072	Auger Motor Mount	1
11	092-0013	Auger Assembly RH	1
12	018-0105	Auger Bearing (bearing replacement)	1
13	112-302080	Auger Hanger Assembly (includes bearing)	1
14	015-0154	Auger Sprocket	1
15	015-0045	Auger Chain Coupler	1
(Not Shown)	050-0350	Electrical Cord Auger Sensor	1

Left End Gate Assembly

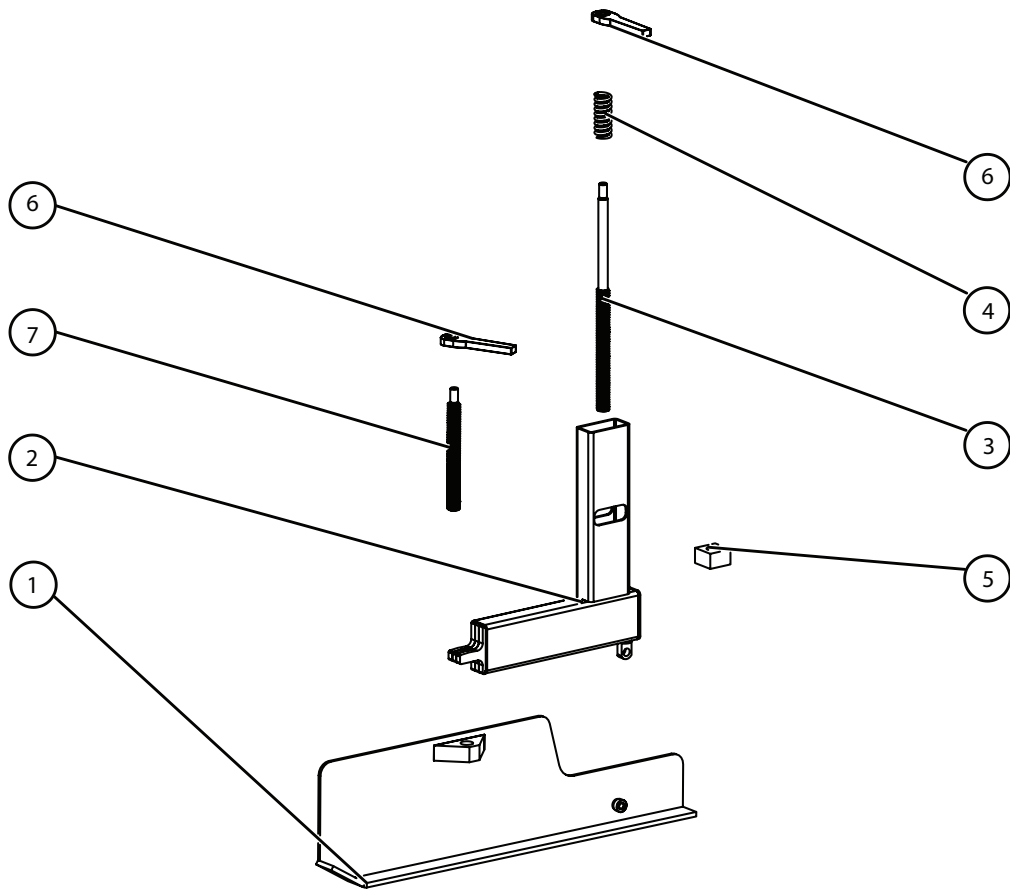

Left End Gate Assembly

BOM ID	Part Number	Description	Quantity
1	112-209461	End Gate Shoe LH	1
2	112-209450	End Gate Lower Weldment	1
3	112-302376	Threaded Rod End Gate Height	1
4	050-0342	Spring	1
5	113-209462	End Gate Adjustment Nut	1
6	111-104170	Handle Ratcheting	2
7	113-209468	Threaded Rod End Gate Pivot	1
8 (Not Shown)	111-209451	Complete Assembly Endgate LH	1

Right End Gate Assembly

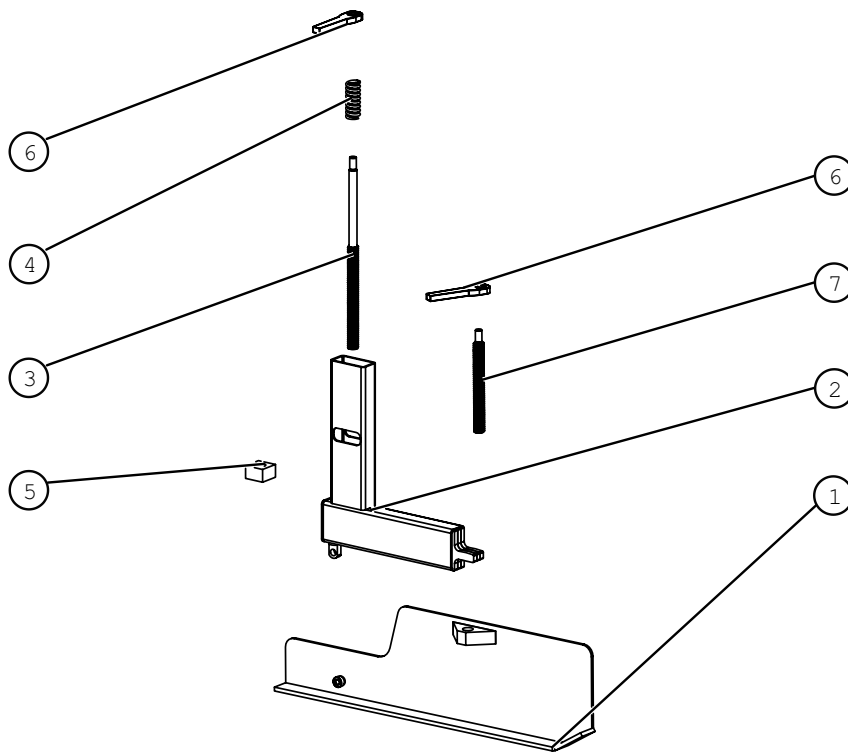

Right End Gate Assembly

BOM ID	Part Number	Description	Quantity
1	112-209460	End Gate Shoe RH	1
2	112-209450	End Gate Lower Weldment	1
3	112-302376	Threaded Rod End Gate Height	1
4	050-0342	Spring	1
5	113-209462	End Gate Adjustment Nut	1
6	111-104170	Handle Ratcheting	2
7	113-209468	Threaded Rod End Gate Pivot	1
8 (Not Shown)	111-209450	Complete Assembly Endgate RH	1

Screed Heat Components

No Exploded View Available

Screed Heat Components

BOM ID	Part Number	Description	Quantity
1	020-0577	Screed Heat Control System Assembly	1
2	112-109290	Propane Burner	2
3	020-0562	Hot Surface Ignitor	4
4	090-0231	Hand Torch Assembly	1
5	-130112	Control box (Enclosure only)	1
6	020-0564	Time Delay Relay	1
7	-E0141	12v Relay	3
8	020-0405	Toggle Switch On/Off	1
9	020-0574	Indicator light	1
10	020-0574	Wire Harness	1
11	050-0049	Propane Regulator	1

THIS PAGE LEFT BLANK INTENTIONALLY

Schematics

Electrical Schematic

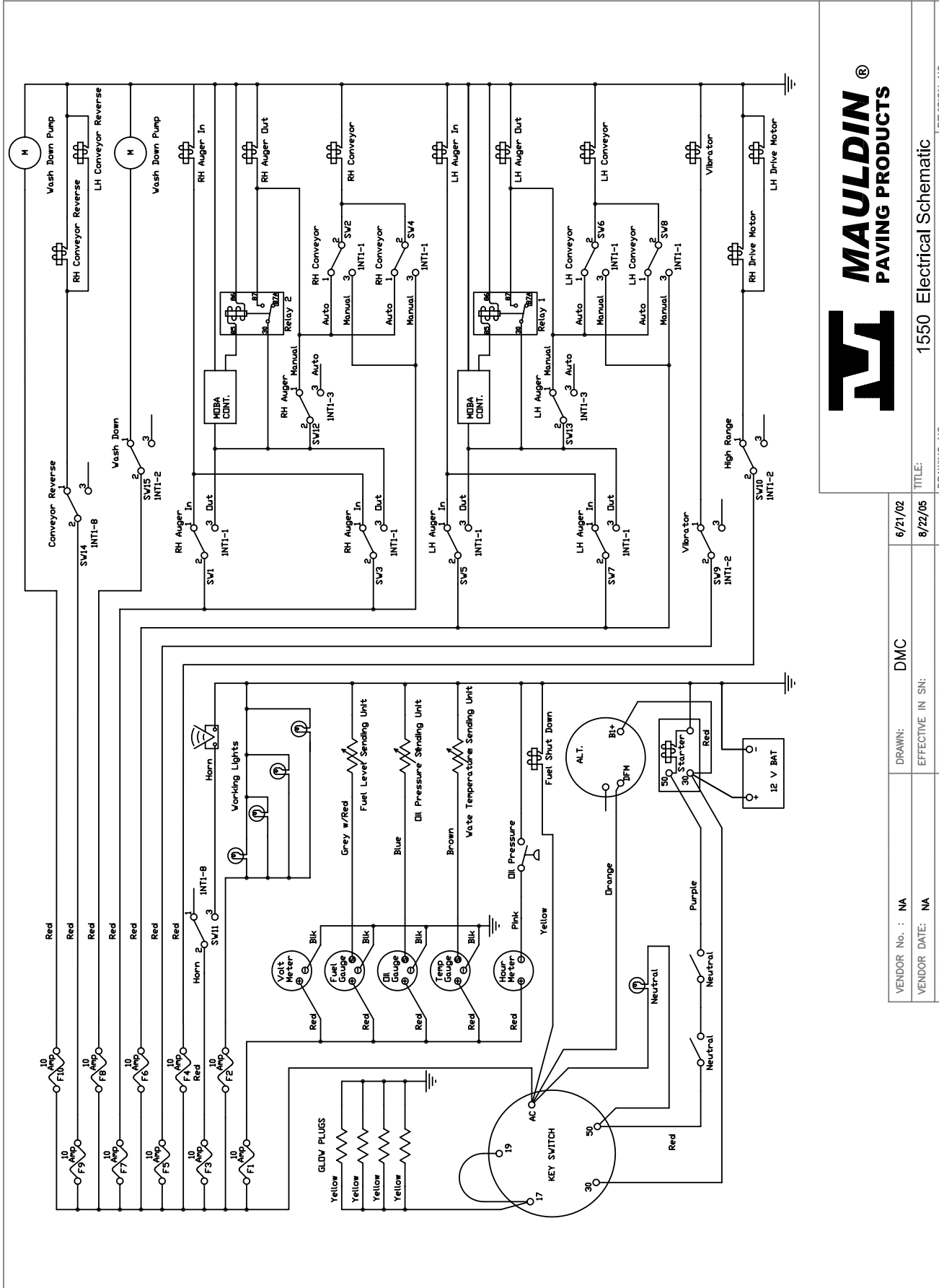

1550 Electrical Schematic

6/21/02

DMC

DRAWN:

NA

VENDOR DATE:

EFFECTIVE IN SN:

REVISION NO.

TITLE:

8/22/05

DRAWING NO.

EFFECTIVE IN SN:

...

REVISION NO.

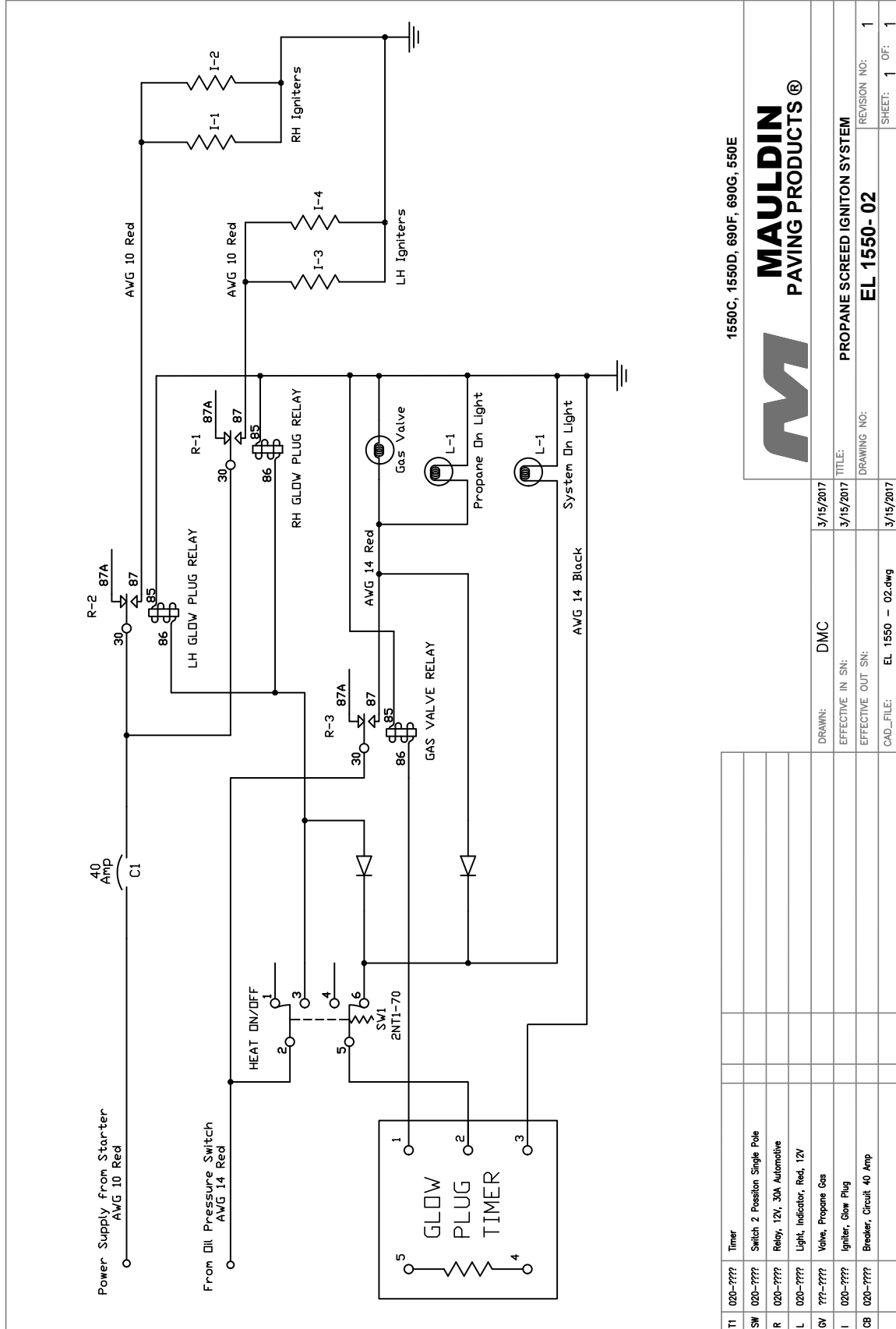

1550C, 1550D, 690F, 690G, 550E



MAULDIN
PAVING PRODUCTS®

T1	020-????	Timer			
SW	020-????	Switch 2 Position Single Pole			
R	020-????	Relay, 12V, 30A Automotive			
L	020-????	Light, Indicator, Red, 12V			
GV	???-????	Valve, Propane Gas			
I	020-????	Igniter, Glow Plug			
CB	020-????	Breaker, Circuit 40 Amp			

DRAWN:	DMC	3/15/2017
EFFECTIVE IN SIN:		3/15/2017
EFFECTIVE OUT SIN:		
CAD_FILE:	EL 1550 - 02.dwg	3/15/2017

PROPANE SCREED IGNITON SYSTEM

EL 1550- 02

REVISION NO: 1

SHEET: 1 OF: 1

Hydraulic Schematics

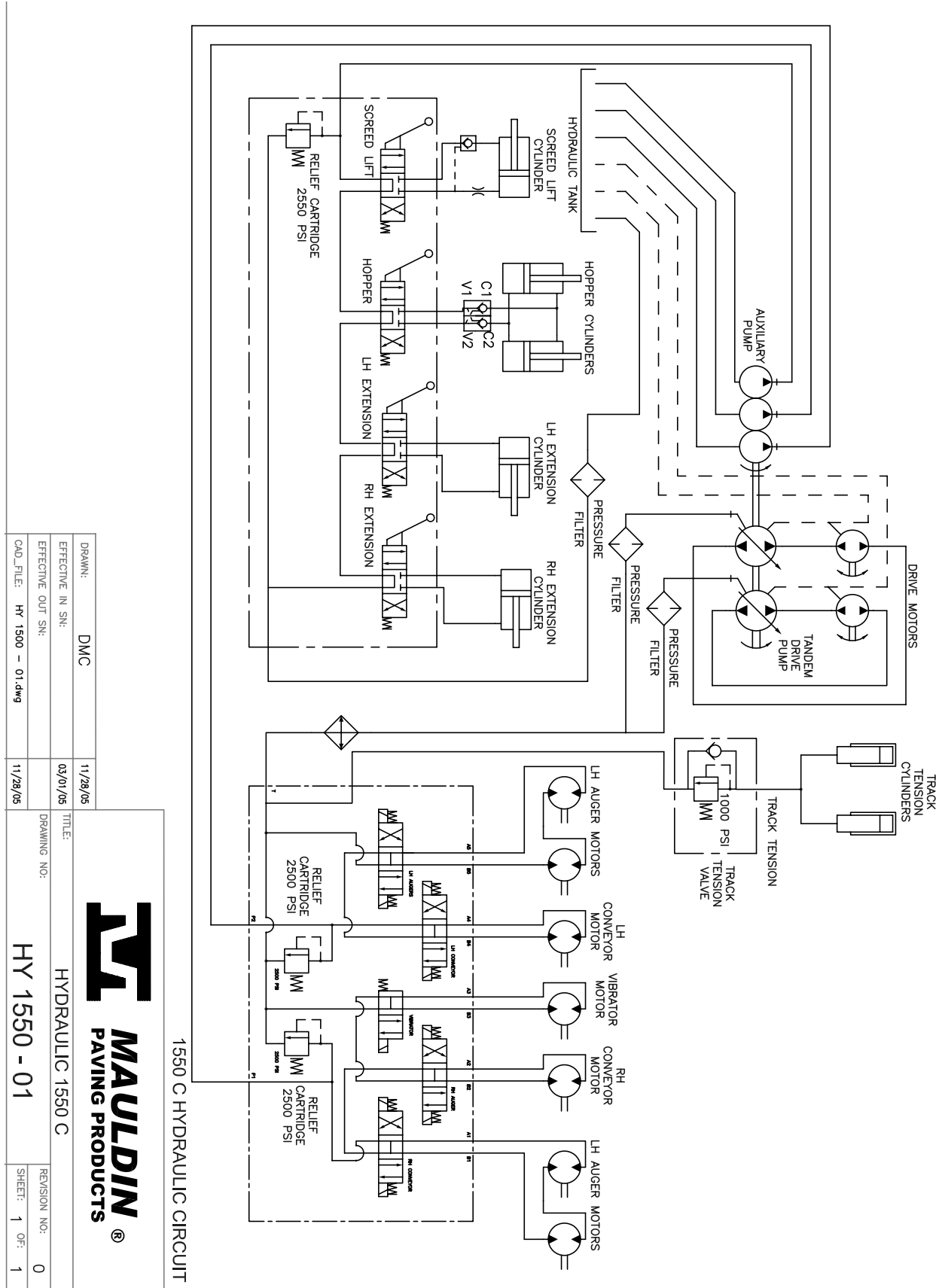

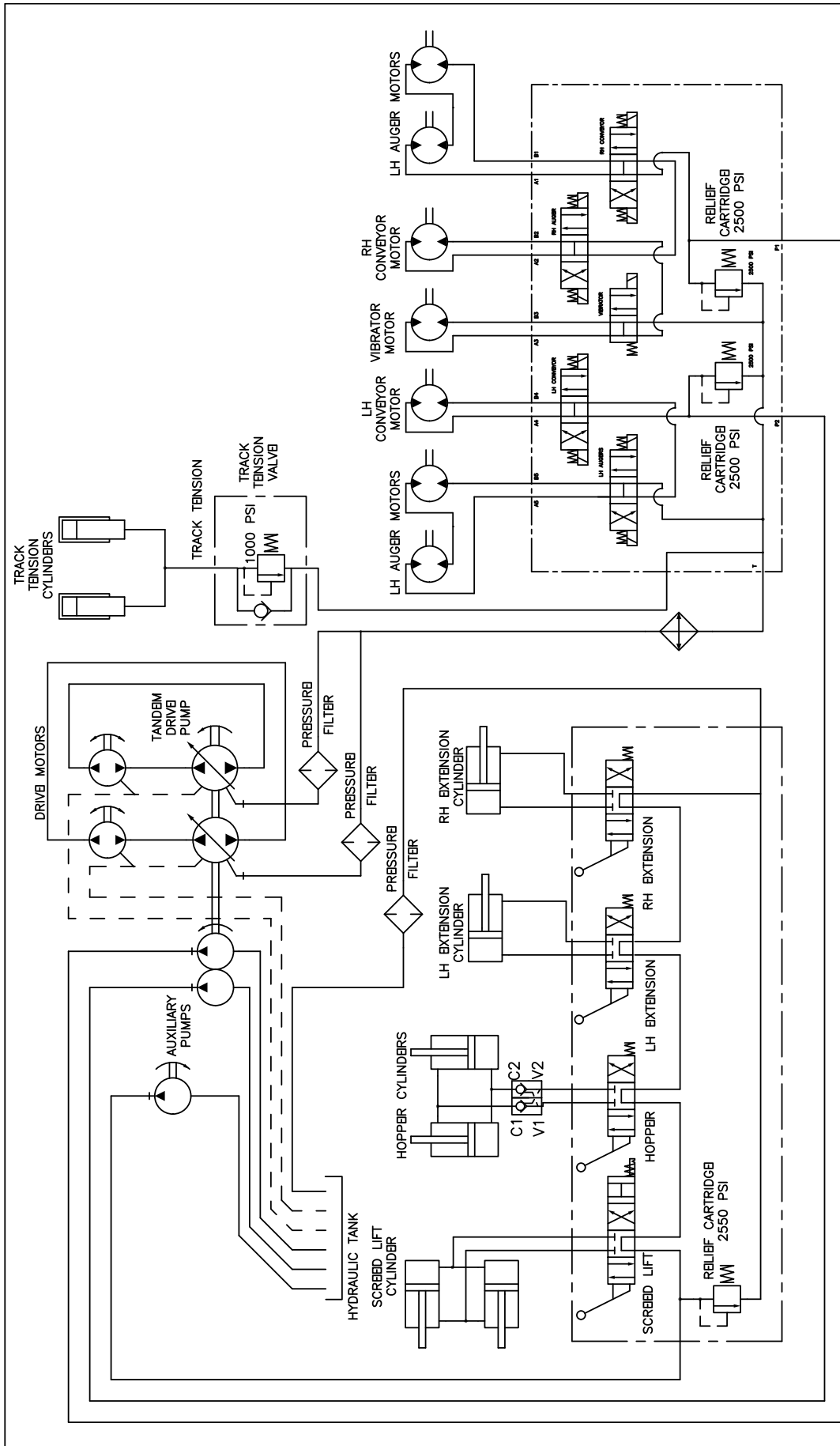

1550 C HYDRAULIC CIRCUIT



DRAWN:	DMC	11/28/05
EFFECTIVE IN SN:		03/01/05
EFFECTIVE OUT SN:		

TITLE: HYDRAULIC 1550 C

DRAWING NO: IIV 4550 04

REVISION NO: 0



CALDER BROTHERS CORPORATION
(LIMITED) PRODUCT WARRANTY

Calder Brothers Corporation warrants that the Paver, Roller, Tank or Grader under this program will be free from defects in material and workmanship for a period of (12) twelve months from the date of installation. Written notice of any claimed defect must be given to Calder Brothers Corporation within the warranty period and within (30) thirty days after such defect is discovered. Liability under this warranty is limited to replacing or repairing at Calder Brothers Corporation election, any part or parts deemed defective after examination by Calder Brothers Corporation or an Authorized Service Representative via prepaid transportation for which is found to be defective, will be repaired or replaced and returned to the customer via prepaid surface transportation within the United States. Should any part be found not defective, inspection and handling may be charged to the customer by Mauldin or an Authorized Service Representative.

EXCLUSIONS:

This warranty does not apply to routine wearable parts of the Mauldin machine such as seals, points, plugs, hoses or similar items. This warranty does not extend to any machine or part replaced or repaired under this warranty. This warranty does not cover any repair or replacement labor or any part of parts found defective after examination by Mauldin or an Authorized Service Representative. This warranty does not apply to defects caused by casualty or unreasonable use, including faulty repairs by others and failure to provide reasonable and necessary maintenance.

THIS WARRANTY SET FORTH HEREIN IS IN LIEU OF AND EXCLUDES ANY AND ALL OTHER WARRANTIES, EXPRESSED OR IMPLIED, ARISING BY OPERATION OF LAW OR OTHERWISE, INCLUDING, BUT NOT LIMITED TO, ANY IMPLIED WARRANTY OF MERCHANTABILITY OR FITNESS FOR A PARTICULAR PURPOSE, AND CUSTOMER WAIVES ANY OBLIGATION OF LIABILITY OF MAULDIN ARISING IN TORT OR STRICT LIABILITY IN TORT, OR FOR LOSS OR USE, REVENUE OR PROFIT WITH RESPECT TO MAULDIN MACHINE AND/OR PARTS FOR ANY LIABILITY OF CUSTOMER TO ANY THIRD PARTY, OR FOR OTHER DIRECT, INCIDENTAL OR CONSEQUENTIAL DAMAGES.

I have read and fully understand the warranty policy above.

Customer
CALDER BROTHERS CORPORATION

Witness