



Operation Manual

Model: 1860B

Covers Serial Number Range:

874-S-86TCX5Y2*03874 through _____

Sold & Serviced By:

California Proposition 65 Warnings

⚠ WARNING

Breathing diesel engine exhaust exposes you to chemicals known to the State of California to cause cancer and birth defects or other reproductive harm.

Always start and operate the engine in a well-ventilated area.

If in an enclosed area, vent the exhaust to the outside.

Do not modify or tamper with the exhaust system.

Do not idle the engine except as necessary.

For more information go to www.P65Warnings.ca.gov/diesel

⚠ WARNING

Batteries, battery posts, battery terminals, and related accessories can expose you to chemicals including lead and lead compounds, which are known to the State of California to cause cancer and birth defects or other reproductive harm.

For more information go to www.P65Warnings.ca.gov

Contents

1. Introduction.....	1
1.1 Machine Components	1
1.2 Serial Number Plate	2
1.3 Operator Orientation	2
2. Safety.....	3
2.1 General Safety Information.....	3
2.1.1 Safety Alert And Signal Words.....	3
2.2 Operation Hazards.....	3
2.2.1 ▲ Pressurized Fluids.....	5
2.2.2 ▲ Hazardous Chemicals	6
2.2.3 California Proposition 65 Warnings.....	6
2.2.4 Hazards From Modifying Equipment.....	6
2.3 Maintenance Hazards	6
2.3.1 ▲ Maintenance And Service	7
2.3.2 ▲ Fire Or Explosion Prevention	7
2.4 Safety Decals	7
3. Paver Operation.....	10
3.1 Operators Station	10
3.2 Digital Display	12
3.2.1 Engine Warning Lamps.....	12
3.2.2 Engine Screen.....	12
3.2.3 Material Feed Screen.....	13
3.2.4 Screed Temperature Screen	13
3.2.5 Password Screen.....	14
3.3 Prestart Checks	14
3.4 Start Engine.....	14
3.5 Idle/Pave And Engine Speed.....	15
3.6 Emergency Stop	15
3.7 Active Station	16
3.7.1 Single Operator Feed Control Mode	16
3.7.2 Dual Operator Feed Control Mode	16
3.8 Driving	16

- 3.9 Pause/Resume 17**
- 3.10 Travel Speed..... 17**
- 3.11 Tow Points 18**
- 3.13 Screed Heat 19**
- 3.14 Match Height 19**
- 3.15 Hopper 19**
- 3.16 Prime Fuel System..... 20**
- 3.17 Paver Shutdown..... 20**
- 4. Material Feed..... 22**
 - 4.1 Automatic Material Feed Operation 22**
 - 4.2 Manual Material Feed Operation 24**
 - 4.3 Sonic Sensors 25**
 - 4.4 Screed Heating System..... 26**
- 5. Screed Setup..... 27**
 - 5.1 Crown Setting..... 27**
 - 5.2 Extension Setting 29**
 - 5.2.1 Prepare Paver For Screed Adjustments 29**
 - 5.2.2 Set Match Height 29**
 - 5.2.3 Set Extension Slope 30**
 - 5.2.4 Set Extension Bottom Angle Of Attack 30**
 - 5.3 Pre-Strike Off Setting..... 31**
 - 5.4 Setting Screed To Pave 32**
 - 5.4.1 Before Paving 32**
 - 5.4.2 Nulling The Screed And Setting Angle Of Attack 32**
- 6. Inspections And Maintenance 33**
 - 6.1 Inspection And Maintenance Chart 33**
 - 6.1.1 Fluid Capacities 34**
 - 6.2 Prepare Paver For Inspections And Maintenance 34**
 - 6.3 Daily Before Use 34**
 - 6.3.1 Check Engine Oil Level..... 34**
 - 6.3.2 Check Engine Coolant Level 35**
 - 6.3.3 Check Engine Fuel And DEF Levels 35**
 - 6.3.4 Check Hydraulic Oil Level 36**

6.3.5 Verify Lights Are Operable	36
6.3.6 Check Horn And Signal Devices	36
6.3.7 Check Safety Decals	36
6.3.8 Check Engine Radiator Intake Screen.....	36
6.3.9 Drain Fuel/Water Separator	37
6.4 Daily After Use	37
6.4.2 Wash Paver	37
6.5 After Initial 50 Hours	37
6.5.1 Change Hydraulic Filters	37
6.5.2 Change Engine Oil And Oil Filter	38
6.6 Monthly / Every 250 Hours	38
6.6.1 Inspect Conveyor And Drive System.....	38
6.6.2 Change Engine Oil And Oil Filter	39
6.7 Yearly / 500 Hours	39
6.7.1 Change Hydraulic Oil And Filters	39
6.7.2 Change Engine Coolant.....	40
6.7.3 Change Engine Fuel Filters	40
6.5.4 Change Engine Air Filter.....	40
6.7.5 Clean Engine Radiator Fins And Screen.....	40
6.7.6 Battery	40
6.7.7 Fill/Drain Planetary Fluid	41
7. Troubleshooting	42
7.1. General	42
7.2 Engine Codes	43
7.3 Troubleshooting Chart	43
8. Screed Automation Control System	44
8.1 Initial Setup	44
8.2. Mounting the Sensors	44
8.2.1 Ground Mode (Single Grade Sensor and 4-Head Averaging Sensor)	44
8.2.3 Stringline Mode (4-Head Averaging Sensor Only).....	45
8.3 Hand Held Controller Setup	46
8.3.1 Manual Mode Functions.....	46
8.3.2 Auto Mode Functions	46
8.3.3 Factory Default Settings	46

8.3.4 Changing Hand Held Out Put	47
8.3.5 Changing from Metric to English Measurements:.....	47
8.4 Single Grade Setup.....	47
8.5 Error Codes	48
8.6 Daily Automation Setup	49
9. Warranty	50

1. Introduction

1.1 Machine Components

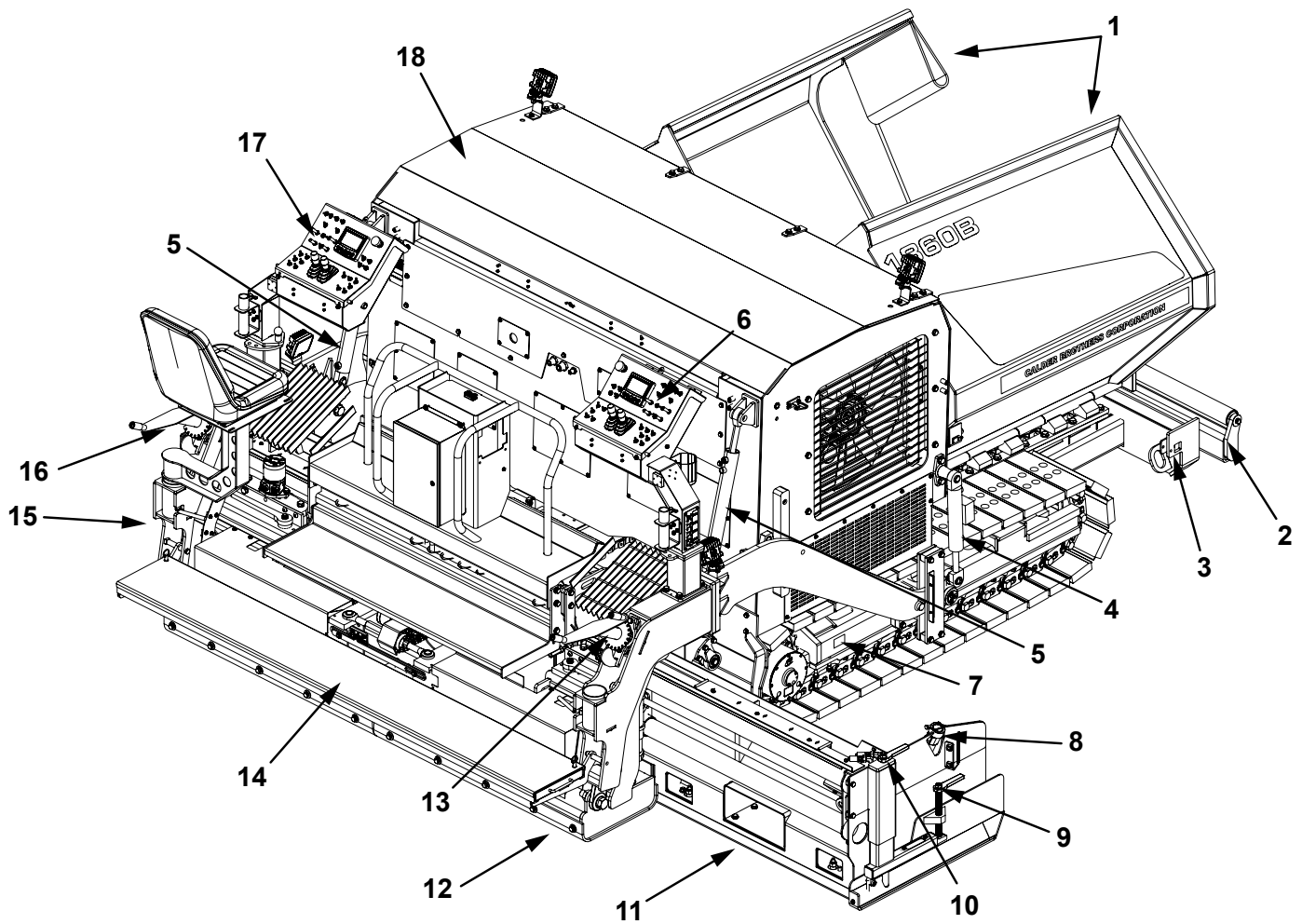

- 1. Hopper
- 2. Push Beam
- 3. Shipping Front Tie Down (Both Sides)
- 4. Tow Point Cylinder
- 5. Screed Lift Cylinder
- 6. Right Hand Control Panel
- 7. Shipping D-Ring
- 8. Sonic Sensor
- 9. Right Hand End Gate Angle Adjustment
- 10. Right Hand End Gate Depth Adjustment
- 11. Right Hand Extension
- 12. Main Screed
- 13. Right Hand Depth Adjustment
- 14. Walk Board
- 15. Left Hand Extension
- 16. Left Hand Depth Adjustment

- 17. Left Hand Control Panel
- 18. Engine Enclosure

1.2 Serial Number Plate

Serial number plate is located on the left side of the engine enclosure. Record serial number and date in spaces below.

Serial Number: _____

Date Of Purchase: _____

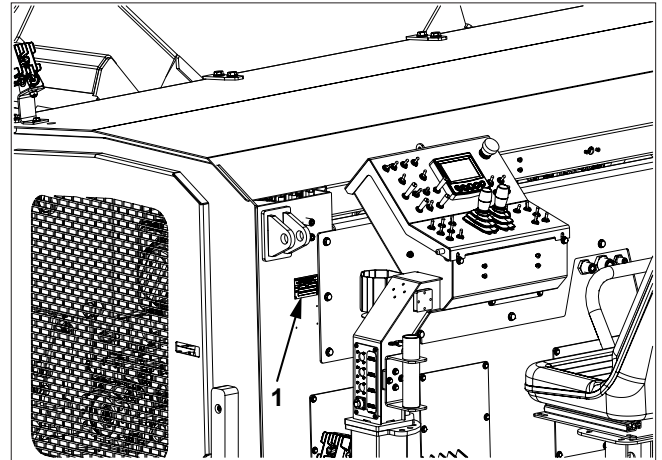

1.3 Operator Orientation

- 1. Front
- 2. Right Side
- 3. Rear
- 4. Left Side

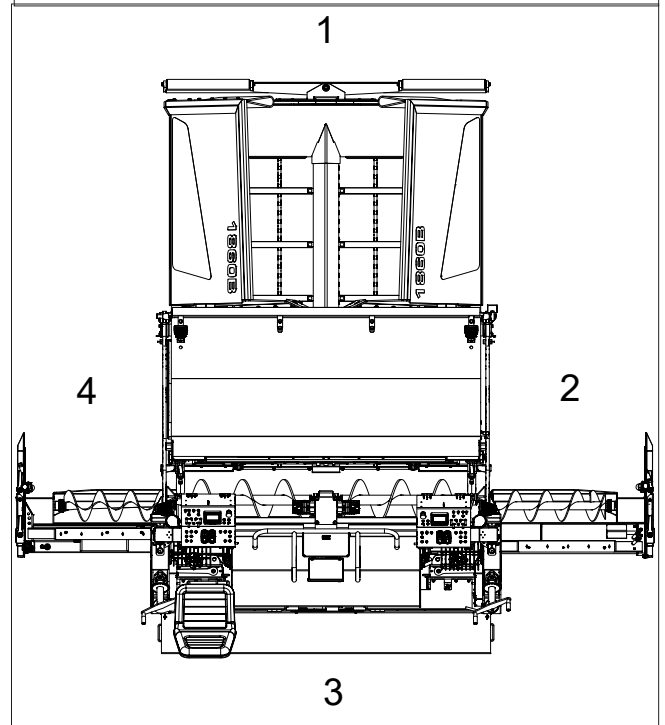

2. Safety

2.1 General Safety Information

Operating personnel must perform service checks regularly to be sure systems are in good operating condition. If abnormal conditions are detected, inform maintenance personnel immediately.

Check all systems for proper operation. Check chassis and all components for physical damage and security of all fasteners and connectors.

2.1.1 Safety Alert And Signal Words

The safety information in this manual is denoted by the safety alert symbol:  This symbol means ATTENTION! BECOME ALERT! YOUR SAFETY IS INVOLVED!

DANGER

Indicates a hazardous condition that will result in serious injury or death if not performed appropriately.

WARNING

Indicates a hazardous condition that could result in serious injury or death if not performed appropriately.

CAUTION

Indicates a hazardous condition that could result in serious injury if not performed appropriately.

NOTICE

Indicates a situation that could result in damage to the machine or other property.

2.2 Operation Hazards

The following hazards are possible during the operation of the paver. All operators, maintenance and service personal, or any one working with or near the paver must be familiar all hazards.

WARNING

Do not operate this paver until you read and understand the instructions in the operation section of this manual.

WARNING

Do not operate, work on or around paver while under the influence of alcohol, drugs or if feeling ill.

⚠ WARNING

Explosion, fire, or property damage hazard.

Do not use starting fluid with this engine.

Use of starting fluid can cause an explosion, fire, personal injury or damage to the engine and other property.

⚠ WARNING

Loud noise hazard.

Prolonged exposure to loud noise can cause impairment or loss of hearing.

Operators, workers and bystanders must use ear protection while machine is in operation.

⚠ WARNING

Entanglement hazard.

Do not wear loose fitting clothing.

Loose fitting clothing and long hair can become entangled in moving or rotating parts. Keep all personnel clear of moving parts when engine is running or about to be started.

Long hair must be tied back or netted.

Keep clear of moving components.

Never operate machine with open or missing guards or shields.

⚠ WARNING

Fire, burns or property damage hazard.

During aftertreatment regeneration, exhaust gas temperature could reach 1500°F (800°C). Exhaust system surface could exceed 1300°F (700°C) which is hot enough to ignite or melt common materials and burn the skin.

Exhaust and exhaust components can remain hot after engine has been stopped.

To avoid risk of fire, burns and property damage or personal injury, allow the exhaust system to cool before service or repairs.

Be sure there are no combustible materials located where they are likely to come in contact with hot exhaust or exhaust components.

⚠ WARNING

Explosion, fire, or personal injury.

This engine is equipped with an air intake heater.

Do not use starting fluid with this engine.

Use of starting fluid can cause an explosion, fire, personal injury or damage to the engine and other property.

⚠ WARNING

Diesel exhaust fluid (DEF) hazard.

In case of contact with eyes, immediately flush eyes with water. Obtain medical attention immediately.

In case of skin contact, wash all exposed skin area with mild soap and water, followed by warm water rinse.

If ingested, obtain medical attention immediately.

⚠ WARNING

Crush hazard.

A raised screed or partially open hopper will fall if a hydraulic line or fitting is opened, or manual override button on hydraulic valve is pressed.

Always fully close hopper and lower screed to ground or engage screed service locks when parking paver or preparing paver for inspections, service and maintenance.

NOTICE

Dispose of waste properly.

Improper disposal of waste can harm the environment.

Use leak proof container when draining fluids. Do not use food or beverage containers.

Contact your local environmental or recycling center for the proper way to recycle or dispose of waste.

2.2.1 ⚠ Pressurized Fluids

Hydraulic oil and grease injected into your skin can cause serious injury or death. Keep your hands and body away from any pressurized leak. Tighten connections before applying pressure. Never use your hand to check for leaks; use a piece of wood or cardboard. If fluid is injected into the skin, it must be surgically removed within a few hours or gangrene may result. Get immediate medical attention.

2.2.2 Hazardous Chemicals

Lubricants and coolants can be hazardous. Before operating, check the Material Safety Data Sheet (MSDS) to understand each product, safe handling procedures, and first aid measures relating to the product. Clean up spilled fluids immediately.

Do not drain or pour any fluids or lubricants on the ground. Check with local environmental agencies or recycling centers for proper disposal information.

2.2.3 California Proposition 65 Warnings

WARNING

Breathing diesel engine exhaust exposes you to chemicals known to the State of California to cause cancer and birth defects or other reproductive harm.

Always start and operate the engine in a well-ventilated area.

If in an enclosed area, vent the exhaust to the outside.

Do not modify or tamper with the exhaust system.

Do not idle the engine except as necessary.

For more information go to www.P65Warnings.ca.gov/diesel.

WARNING

Batteries, battery posts, battery terminals, and related accessories can expose you to chemicals including lead and lead compounds, which are known to the State of California to cause cancer and birth defects or other reproductive harm.

For more information go to www.P65Warnings.ca.gov.

2.2.4 Hazards From Modifying Equipment

Do not make any alterations to your paver. Altering may cause your equipment to be unsafe and may void the manufacturers' warranty.

Always use Mauldin replacement parts.

2.3 Maintenance Hazards

The following maintenance hazards are in addition to those found while operating the paver. All maintenance and service personal must be familiar with all hazards before working on the machine.

Most accidents are caused by failure to observe basic safety rules or precautions.

An accident can often be avoided by recognizing potentially hazardous situations before an accident occurs.

⚠ WARNING

Improper operation, lubrication or maintenance of this paver can be dangerous and could result in injury or death.

⚠ WARNING

Do not perform any lubrication and maintenance on this paver until you read and understand the instructions in the maintenance section of this manual.

2.3.1 ⚠ Maintenance And Service

Before performing inspections, service or maintenance:

- Park paver on firm level surface.
- Lower screed to ground or engage screed support locks.
- Fully open or close hoppers.
- Turn engine off and remove ignition key.
- Attach a Do Not Operate tag or similar warning tag to the ignition switch.
- Follow lockout/tag out procedure as defined by your company.

After performing inspections, service or maintenance, verify all guards have been installed and all safety devices are functional.

Always wear face or eye protection, safety shoes, and other protective items as required by your company.

If you must troubleshoot machine with engine running, have someone in constant visual contact who can shut off the engine or engage an Emergency Stop.

If you must service machine with an attachment raised, block up that attachment in a safe position.

2.3.2 ⚠ Fire Or Explosion Prevention

⚠ Engine fuel can cause an explosion or fire. Do not service fuel system with engine running or near open fire. Do not weld or smoke near fuel system. Do not spill fuel or hydraulic oil on hot machine components. Clean up spilled fuel or oils immediately.







⚠ Keep sparks and flames away from batteries to prevent explosion of hydrogen gas in and near a battery. Other precautions include:

- When disconnecting battery cables, disconnect negative (-) cable first.
- When connecting battery cables, connect negative (-) cable last.
- Do not short circuit battery posts with metal items.

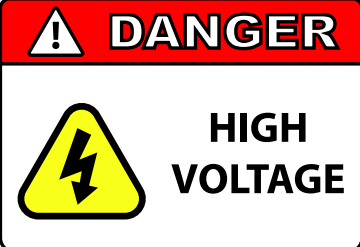
2.4 Safety Decals

Safety decals are located on the paver to identify operational and maintenance hazards. The safety decals are placed according to the hazard in that area of the paver. Read and understand each of the safety decals and the hazard it references. These safety messages are additional information to the safety content described in this operator's manual.

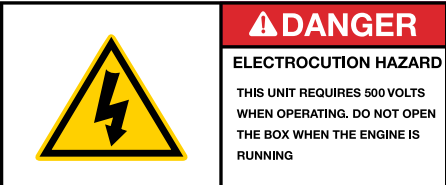
All safety decals must be legible at all times. Avoid using harsh chemicals or pressure washing. If the safety decal is no longer legible, replace it with a new one. Contact your dealer for new decals.

	<p>1 - Danger High Voltage. The generator provides 500V AC for screed heater operation. Avoid working on any electrical components while the engine is on. ONLY factory trained personnel should ever work on the high voltage system.</p>
	<p>2 - Danger Keep Clear. There are moving objects that could result in harm. Keep clear of moving objects. Failure to keep clear may result in serious injury or death.</p>
	<p>3 - Danger Stand Back. There are moving objects that could result in harm. Stand back a safe distance to avoid harm. Failure to keep back may result in serious injury or death.</p>
	<p>4 - Danger Crush Hazard. There are moving objects with sharp and or hard edges. Failure to observe moving parts and keep clear can and will result in serious injury.</p>
	<p>5 - Fan Hazard. Keep away from moving fan.</p>
	<p>6 - Danger High Voltage. This machine uses 500v to operation. Avoid working on any electrical components while the engine is on.</p>
	<p>7 - Caution Moving Augers. Keep clear of moving augers. Failure to do so may result in serious injury or death. Do not stand on or near the augers at any time, even if the machine is not running.</p>
	<p>8 - Danger. Fuel and or flammable fluid is present. Do not smoke or use any open flame. Decal is inside engine enclosure.</p>



9 - Danger. Keep clear. Moving parts can result in harm. Failure to keep clear will result in injury.

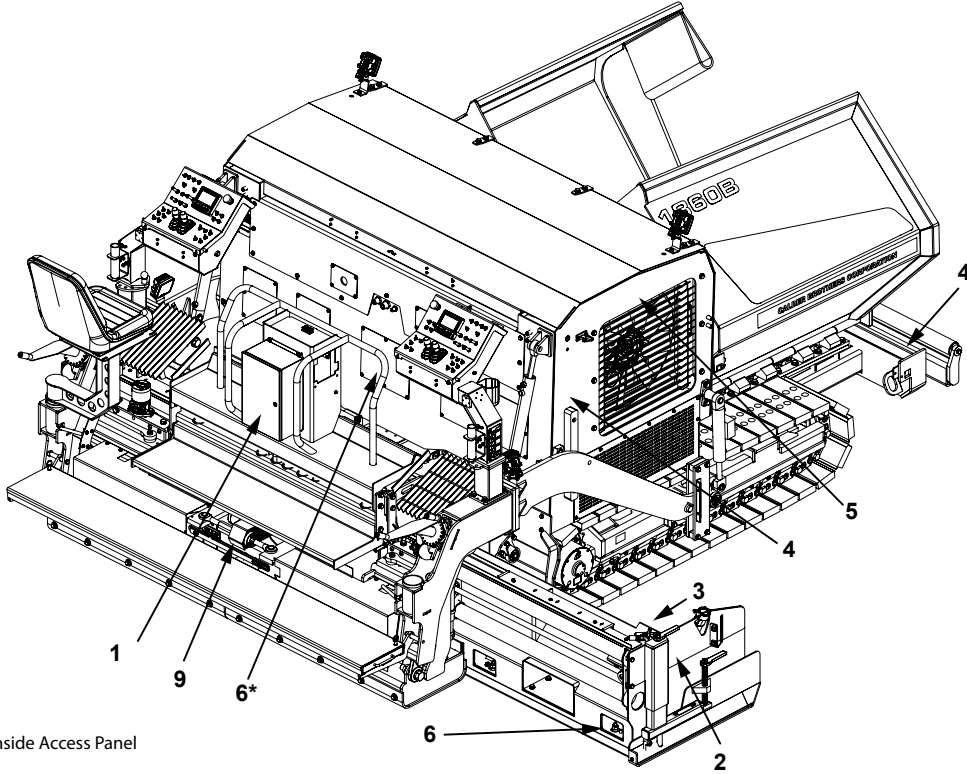

*Inside Access Panel

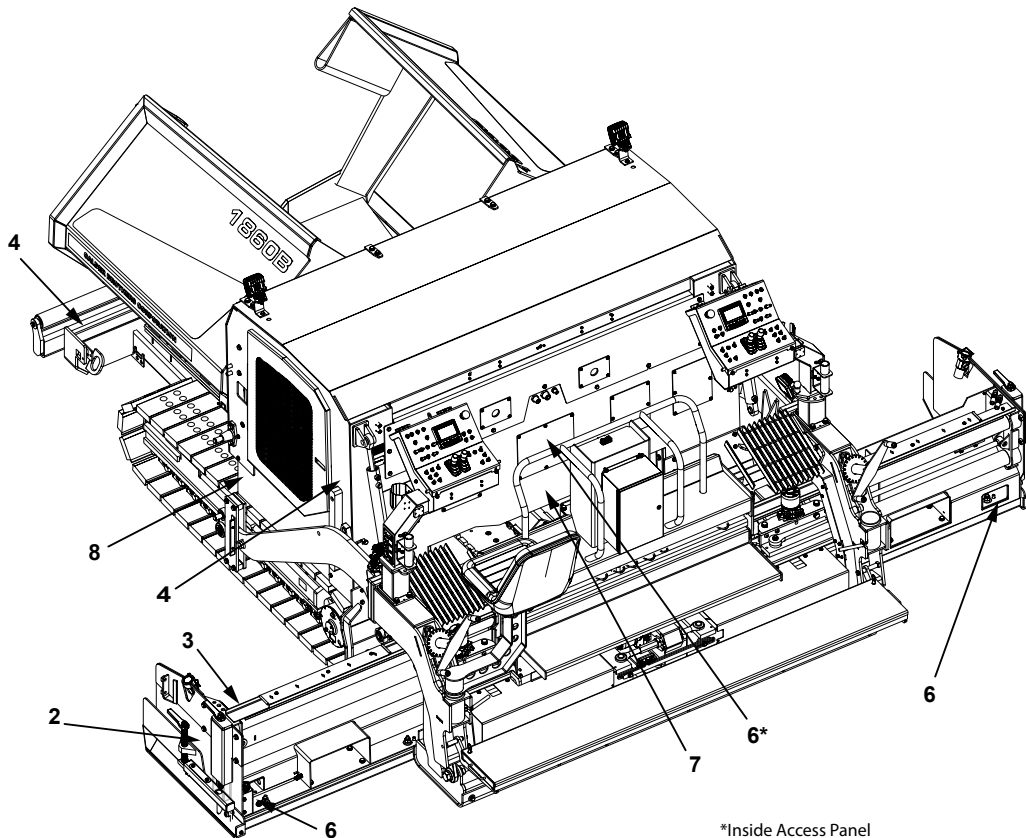

*Inside Access Panel

3. Paver Operation

3.1 Operators Station

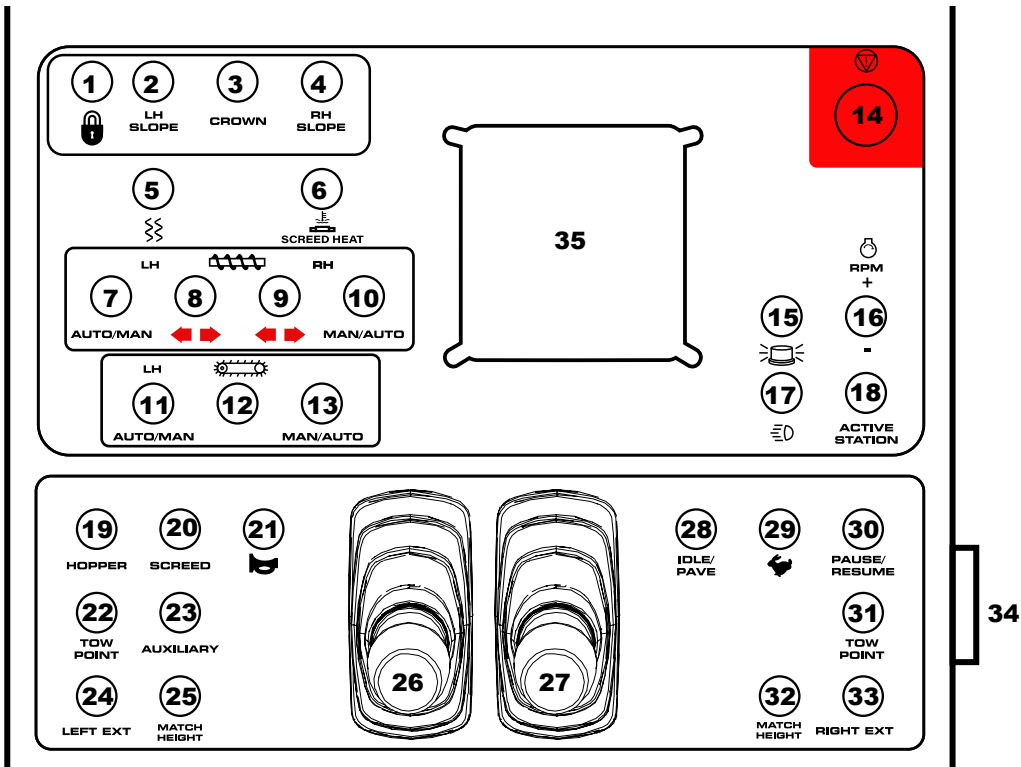

Left Side Station

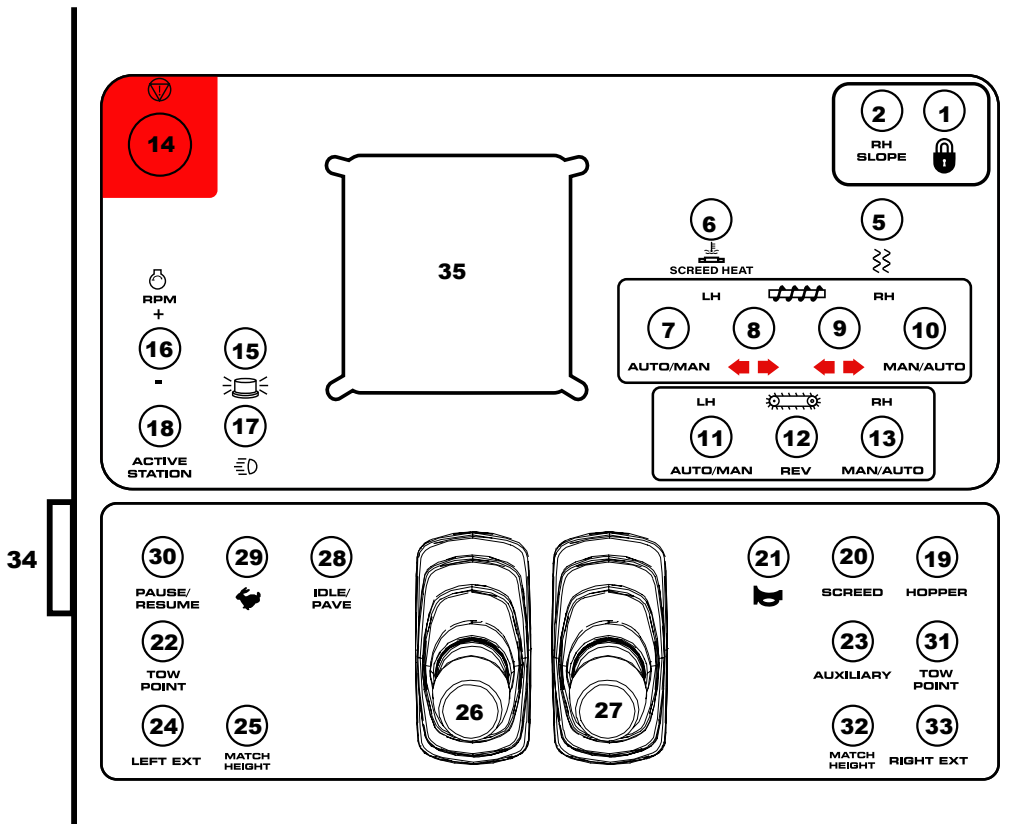

Right Side Station

1. Screed Lock Out/Disable: Disables Slope and Power Crown Adjustments
2. Left Hand Slope (Optional). Adjusts left extension to either flat or angled positions.
3. Crown (Optional). Adjust screed crown.
4. Right Hand Slope (Optional). Adjusts Right extension to either flat or angled positions..
5. Screed Vibrator On/Off. Vibrator only runs when paver is moving forward and screed is in float.
6. Screed Heat: Turns on Screed Heat. Temperature is set in the Digital Display.
7. Left Hand Auger Auto/Manual: Operate auger in auto or manual mode.
8. Left Hand Auger Direction: Augers material to extensions or center of paver for retracting extensions.
9. Right Hand Auger Direction: Augers material to extensions or center of paver for retracting extensions.
10. Right Hand Auger Auto/Manual: Operate auger in auto or manuals mode.
11. Left Hand Conveyor Feed Auto/Manual.
12. Conveyor Reverse: Reverses conveyor direction to return material to the hopper.
13. Right Hand Conveyor Feed Auto/Manual: Operate conveyor in auto or manuals mode.
14. Emergency Stop: Press to stop all paver functions. Pull button out to reset. All functions must be restarted.
15. Beacon Light On/Off.
16. Engine RPM Adjustment: Increase or decrease engine speed in 50 rpm increments.
17. Lights On/Off.
18. Active Station Control: Enables driving/steering control of that station.
19. Hopper: Controls opening and closing of the hopper sides.
20. Screed: Raises and lowers screed. Toggle switch down to place screed in float mode. In float mode, the weight of the screed is dragging the ground, no hydraulics are holding screed up, or pressing it down. The float (down position) of the switch is not momentary. If right hand station has switch in float, and left hand stand toggles switch raise screed, screed will raise up then fall back down to float.
21. Horn.
22. Left Hand Tow Point: Raises and Lowers the Tow Arm on the Tractor
23. Auxiliary: Open for Later Option
24. Left Extension: Extends and retracts left hand screed extension.
25. Left Hand Match Height: Match screed extension height to center screed.
26. Left Track Travel Joystick.
27. Right Track Travel Joystick.
28. Idle/Pave Engine Speed: Select a preset RPM for idle or pave mode.
29. Travel Speed: Select high or low speed. Paving should only ever be done in low speed.
30. Pause/Resume: This function can pause, then resume drive and feed functions.
31. Right Hand Tow Point: Raises and Lowers the Tow Arm on the Tractor
32. Left Hand Match Height: Match screed extension height to center screed.
33. Right Extension: Extends and retracts right hand screed extension.
34. Ignition Switch. Start and stop paver engine.
35. Digital Display

Note: In sections 3.2 - 3.15, the left hand operators station is illustrated. The same functions can be performed from the right hand operators station except where noted.

3.2 Digital Display

This digital display indicates engine oil pressure, engine coolant temperature, battery voltage, engine speed, engine torque being used, diesel exhaust fluid tank level, diesel fuel tank level and engine hours.

3.2.1 Engine Warning Lamps

1. Wait to start indicator. Icon is illuminated when engine preheat is activated.
2. Engine warning code present. Warning symbol (12) will also be illuminated. Check engine codes as soon as possible.
3. Coolant level low. Indicates coolant level is too low. Stop engine immediately.
4. Coolant temperature high. Indicates coolant temperature is too high. Stop engine immediately.
5. Battery voltage low.
6. Oil temperature high. Indicates oil temperature is too high. Stop engine immediately.
7. High speed. Indicates travel switch is in high.
8. DEF tank level low.
9. Force regen. Indicates forced exhaust regen has been activate.
10. Exhaust temperature high. Indicates exhaust temperature is too high.
11. Regen inhibit. Indicates exhaust regen inhibit has been selected.
12. Screed vibration. Icon indicates vibration requested. Screed vibration only operates when paver is moving forward.
13. Warning indicator. Indicates an minor engine warning code is present. Check engine codes as soon as possible. A red stop sign indicates a serious engine code is present and engine must be stopped immediately.

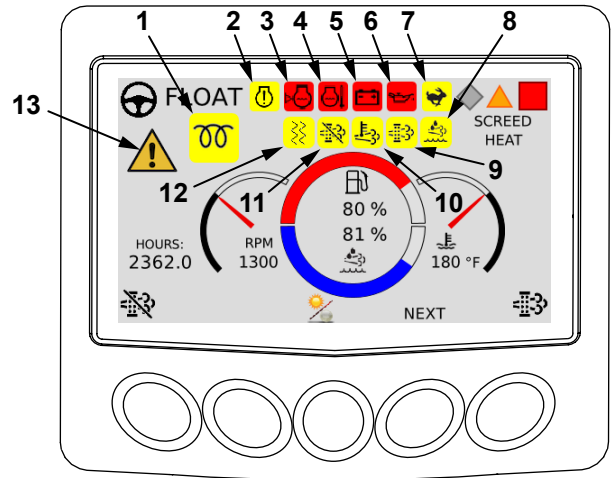

3.2.2 Engine Screen

1. Selected station indicator. This symbol will be displayed on operators station screen with active travel controls.
2. Screed float mode indicator. When illuminated, screed is in float mode.
3. RPM gauge.
4. Fuel tank level.
5. Screed heat status. Indicates status of screed heat zones.
6. Coolant temperature gauge.
7. Force regen. Press to start exhaust regen.
8. Press to move to next screen.
9. Day/night mode.
10. Press to display engine code(s) if present.
11. Regen inhibit. Press to inhit exhaust regen.

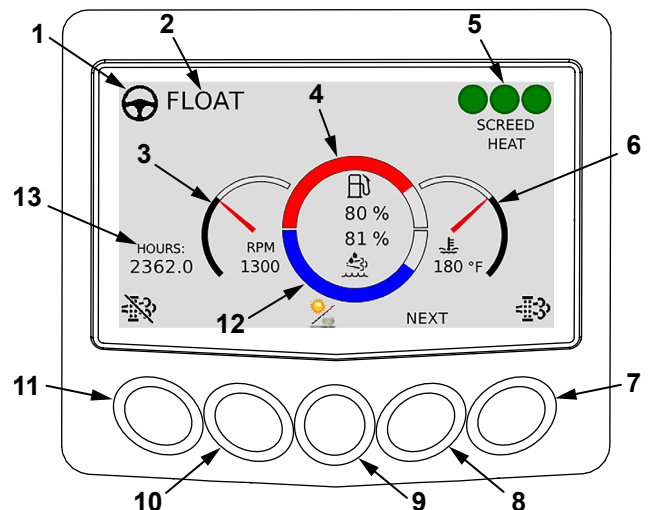

12. DEF tank level.

13. Machine hour meter.

3.2.3 Material Feed Screen

Note: Material feed screen can be viewed at the right hand station, but that the material height change and the dual/single can only be changed from the left hand station.

1. Selected station indicator. This symbol will be displayed on operators station screen with active travel controls.
2. Screed heat status. Indicates status of screed heat zones.
3. Right material height indicator (sonic).
4. Right side material height adjustment. Select low, medium or high.
5. Press to move to next screen.
6. Press to change feed mode. Select dual or single.
7. Press to display engine code(s) if present.
8. Left side material height adjustment. Select low, medium or high.
9. Feed control mode indicator.
10. Left material height indicator (sonic).

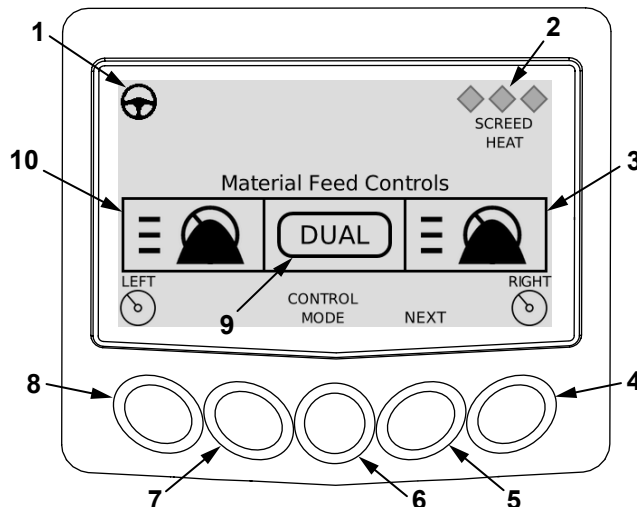

3.2.4 Screed Temperature Screen

Note: Screed temperature can only be changed from the left hand station.

1. Selected station indicator. This symbol will be displayed on operators station screen with active travel controls.
2. Left screed extension status. Display will show ready to pave, wait to pave, off, or fault icon.
3. Main screed status. Display will show ready to pave, wait to pave, off, or fault icon.
4. Right screed extension status. Display will show ready to pave, wait to pave, off, or fault icon.
5. Screed heat status icons. Press and hold help button (8) to show icons.
6. Press to lower screed temperature set point.
7. Press to move to next screen.
8. Press to show icon legend.
9. Press to display engine code(s) if present.
10. Press to raise screed temperature set point.
11. Selected screed heat setpoint. Default temperature is 230°F.

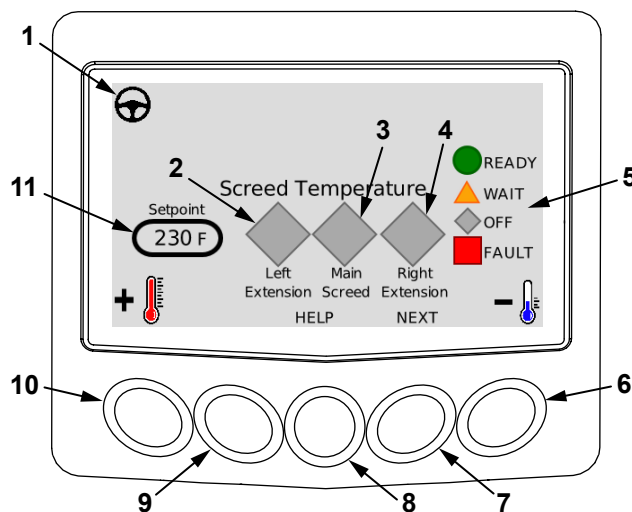

3.2.5 Password Screen

Password screen should only be accessed while being directed by a Mauldin Paving Products service technician.

1. Selected station indicator. This symbol will be displayed on operators station screen with active travel controls.
2. Screed float mode indicator. When illuminated, screed is in float mode.
3. Program version.
4. Display serial number.
5. Machine engine model.
6. Password input field.
7. Press to accept input field value.
8. Press to move to next screen.
9. Press to enter number in input field.
10. Press to cancel input field value.

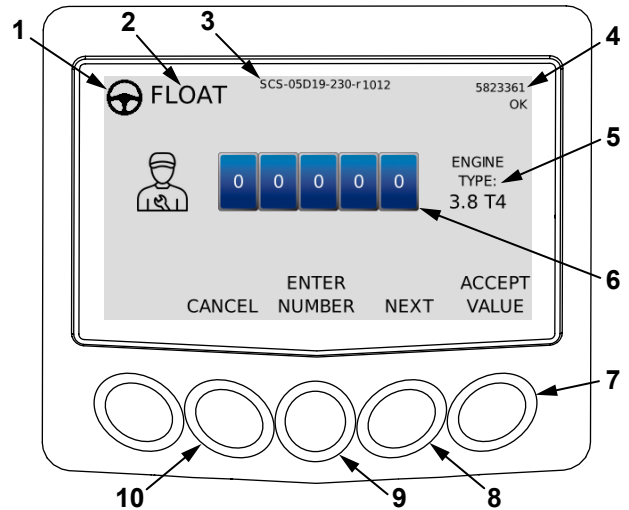

3.3 Prestart Checks

Prior to starting the machine, the following procedures must be completed.

Note: Refer to OEM engine manual for important safety, operational and maintenance information.

1. Check engine oil level.
2. Check engine coolant level.
3. Check hydraulic oil level.
4. Check fuel and DEF levels.
5. Check wash down tank level.
6. Check around machine to verify nothing is on or under the machine.

3.4 Start Engine

⚠ WARNING

Breathing diesel engine exhaust exposes you to chemicals known to the State of California to cause cancer and birth defects or other reproductive harm.

**Always start and operate the engine in a well-ventilated area.
If in an enclosed area, vent the exhaust to the outside.
Do not modify or tamper with the exhaust system.
Do not idle the engine except as necessary.**

For more information go to www.P65Warnings.ca.gov/diesel.

⚠ WARNING

Explosion, fire, or personal injury.

This engine is equipped with an air intake heater.

Do not use starting fluid.

Use of starting fluid can cause an explosion, fire, personal injury or damage to the engine and other property.

1. Turn key switch to on position, pause light indicator should be on.
2. Turn key switch to start and release. During cooler temperatures, there may be slight delay before starter engages while engine preheat is engaged.
3. Run engine at low idle to warm up.
4. Press active station control to enable the driving/steering control on that operators station. Left hand station is the default active station. When engine is started, it will be in pause. The engine will start with a track control lever out of neutral, but you must recenter the levers and toggle pause/resume switch to begin driving.

3.5 Idle/Pave And Engine Speed

Engine will startup at the preset 900 rpm idle speed.

Toggle idle/pave switch (1) to up to increase engine speed to 1800 rpm.

While at paving speed, toggle idle/pave switch (1) down to decrease engine speed to 900 rpm.

Toggle rpm switch (2) up to increase engine rpm or down to decrease rpm. Each toggle of the switch will change engine speed by 100 rpm. Maximum engine speed is 2200 rpm.

Paver will retain engine speed setting when ignition switch is turned off and then on again.

3.6 Emergency Stop

Press emergency stop button (1) to stop all paver functions.

Pull button out to reset. All functions must be restarted.

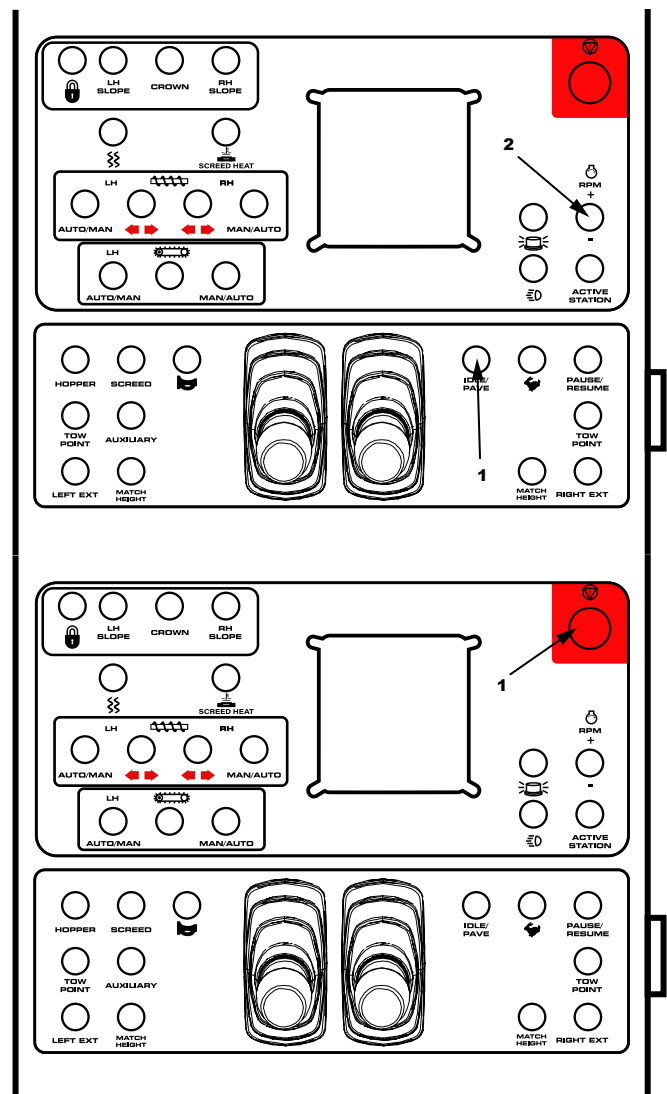

3.7 Active Station

3.7.1 Single Operator Feed Control Mode

This will allow a single operator to control both left and right feed control zones.

1. Start paver engine or move key switch to on position.
2. Select single mode on digital display (1).
3. Go to desired operator station and toggle active station switch (2) to select that station. After toggling active station switch, paver will go into pause mode by default. Toggle pause/resume switch to resume operation.

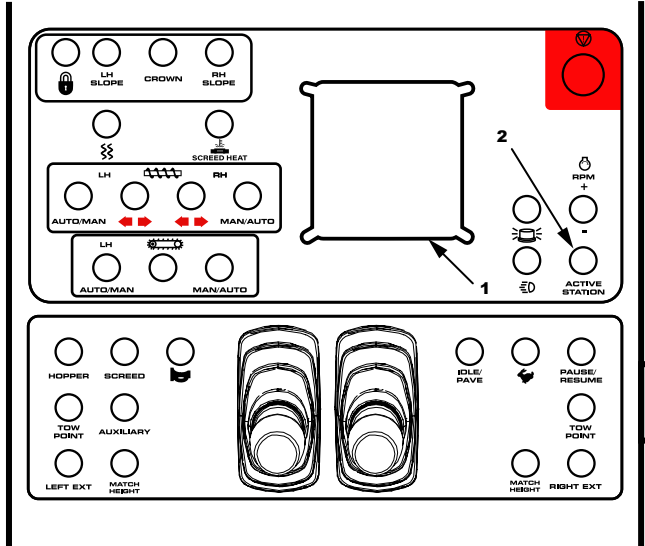

3.7.2 Dual Operator Feed Control Mode

This will allow a single operator to control both left and right feed control zones.

1. Start paver engine or move key switch to on position.
2. Select dual mode on digital display (1).
3. Go to desired operator station and toggle active station switch (2) to select that station for driving/steering.
4. Driving and steering can only be done at selected station. All other paver functions can be operated from either station. After toggling active station switch, paver will go into pause mode by default. Toggle pause/resume switch to resume operation.

3.8 Driving

The paver will move forward by moving track control levers forward, or will move backward by moving levers back. Steering a course is accomplished by adjusting the movement of one lever relative to the other. For best results, move both levers forward or backward to desired speed, then use only one lever to fine tune travel direction.

The farther you move the lever in each direction, the faster that track will move in that direction.

Move levers to the center neutral position to stop movement.

Track control levers must be in the center neutral position at startup.

When switching operator stations, paver will default to pause mode. Quickly toggle pause/resume switch to resume paver operation.

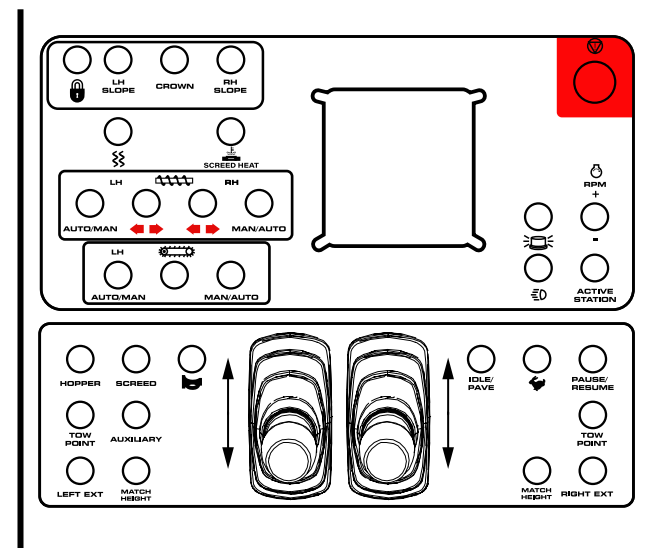

3.9 Pause/Resume

The paver is equipped with a pause/resume function. Pause/resume function allows you to stop the paver and feed function without moving the joystick or feed toggle switches.

While paving:

- Toggle pause/resume switch to stop paver drive and feed functions. Quickly toggle switch again to resume drive and feed functions at the settings they were at when paused.

The pause feature is configurable. In the mechanic's screen you can have the Pause feature only pause the drive, while allowing the feed to continue to fill the screed to proper material height.

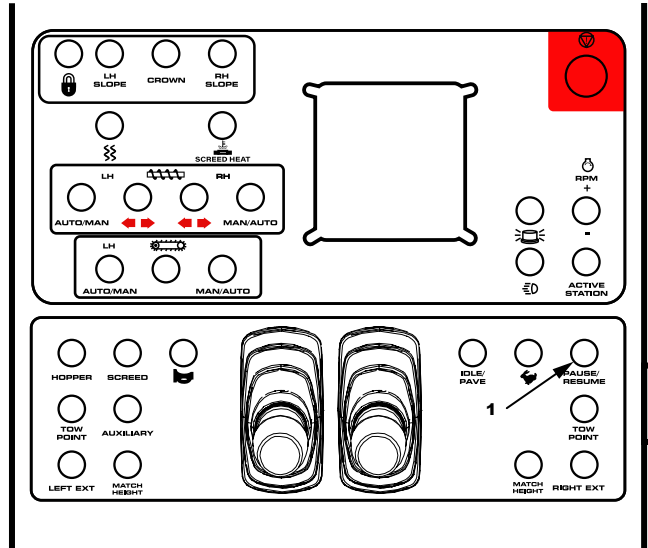

3.10 Travel Speed

Select high or low on travel speed switch (1). Select low speed for paving and machine loading. Select high speed for traveling to and from work site. Engine rpm increases to 2200 rpm when high speed is selected.

If you toggle to high speed and idle/pave switch is in idle, the engine will stay at idle and paver will move at a slightly faster rate. If idle/pave switch is in pave and you toggle to high speed, the engine speed will increase to 2200 rpm and paver will move at a faster rate.

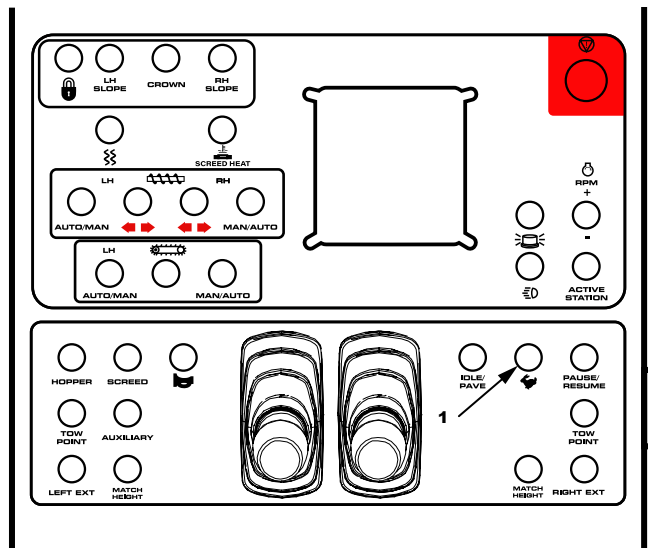

3.11 Tow Points

There are two switches at each operators station. Left switch (1) will adjust left hand tow point cylinder, and right switch (2) will adjust right hand tow point cylinder.

The tow point cylinder (3) on each side adjust the angle of the screed. Before starting to pave, verify cylinders are at their midpoint so half the cylinder piston is exposed.

If equipped with the optional screed automation system, these cylinders will be utilized by the automation system. When operating with out the automation system, switches (1) and (2) may be used in lieu of the manual screed depth cranks.

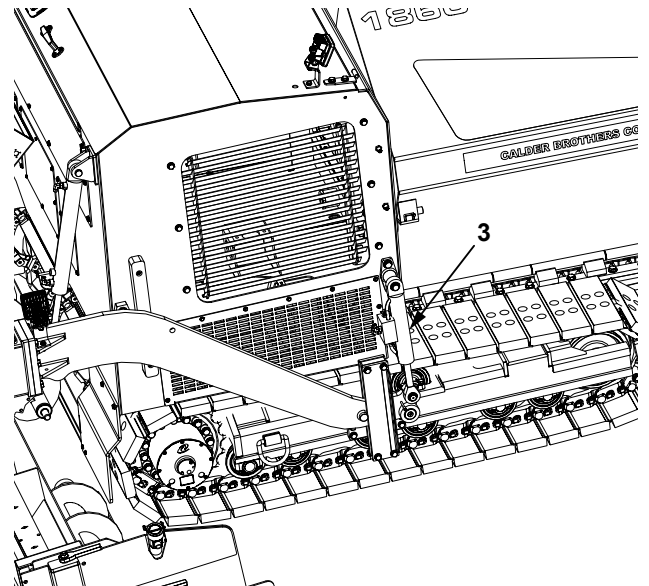
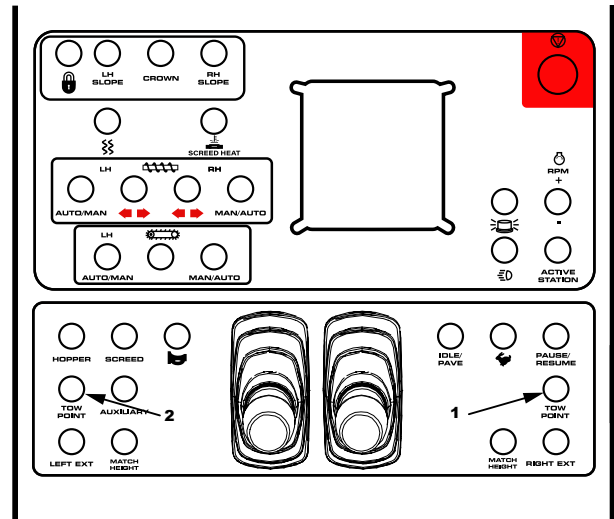

3.12 Exhaust Aftertreatment Regeneration

Note: Refer to the engine OEM manual for important safety, detailed operational and maintenance information on the exhaust aftertreatment system.

The paver is equipped with a regeneration inhibit button and a regeneration force button. Both are located in the digital display on the engine parameter screen (1).

In regen inhibit mode, active cleaning of the after-treatment will not be allowed.

Force regen forces the engine to go into regeneration when it is not calling for it yet.

It is recommended to let the engine regen on its own. Failure to let the engine regenerate will cause it to derate and require mechanic assistance.

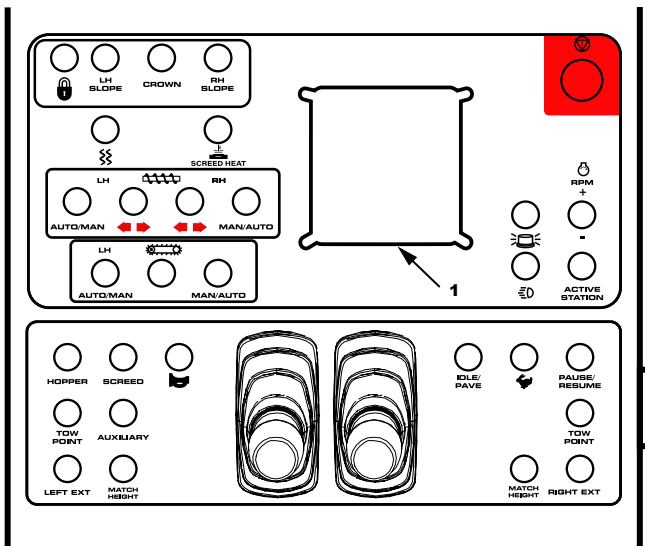

3.13 Screed Heat

Toggle screed heat/generator switch (1) to start/stop generator. The generators only function is to provide electrical power to the screed heating system. Go to the digital display to set screed heat temperature. With generator switch in the on position, generator will start and stop as needed to maintain the selected screed heat temperature.

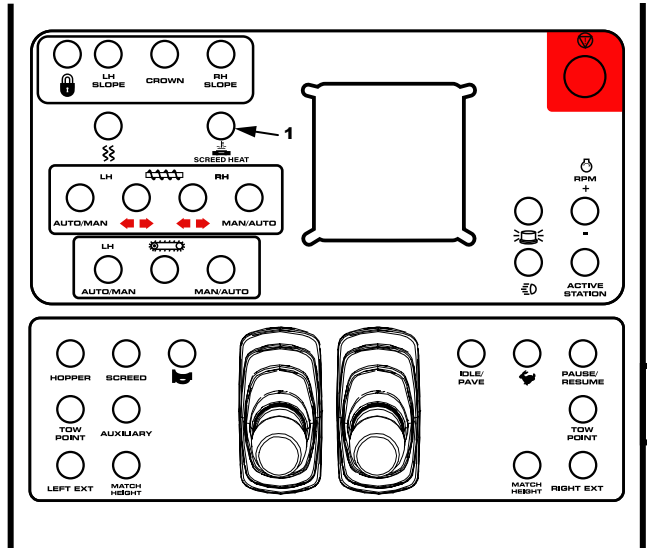

3.14 Match Height

There are two match height switches at each operators station. Left switch (1) will adjust left hand screed extension, and right switch (2) will adjust right hand screed extension. Match height raises or lowers the screed heat extension relative to the main screed.

Toggle match height switches to match left and right screed extensions to center screed height.

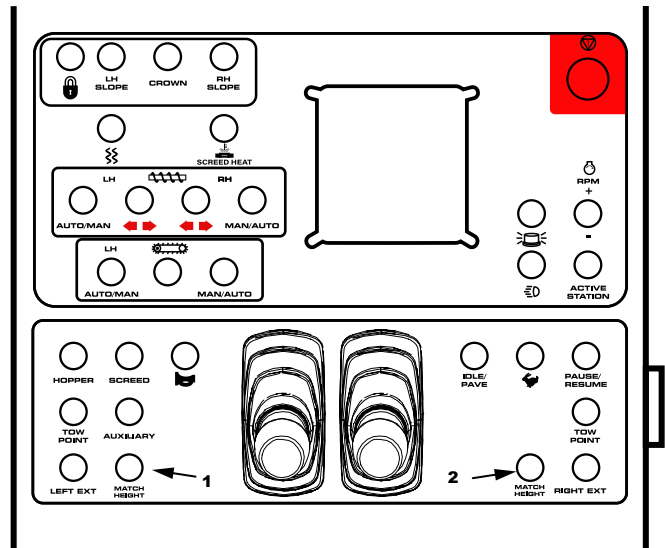

3.15 Hopper

Toggle hopper switch (1) to open and close hoppers.

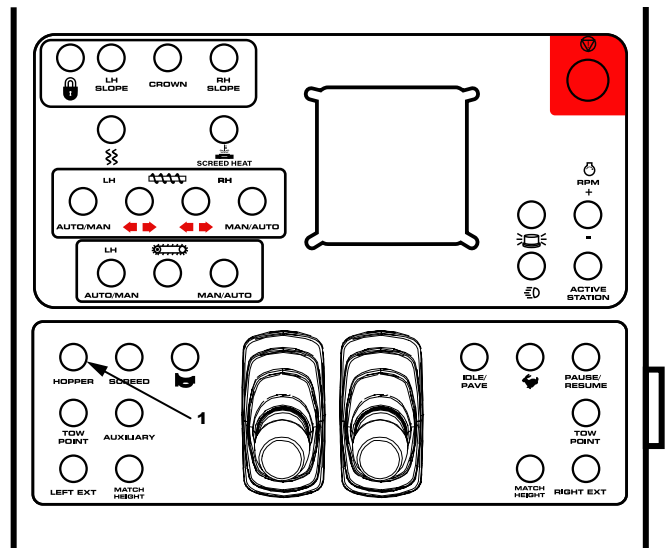

3.16 Prime Fuel System

If engine has run out of fuel, the fuel system will need to be primed after refueling. Loosen primer (1) on fuel/water separator and pump until resistance is felt. Tighten primer.

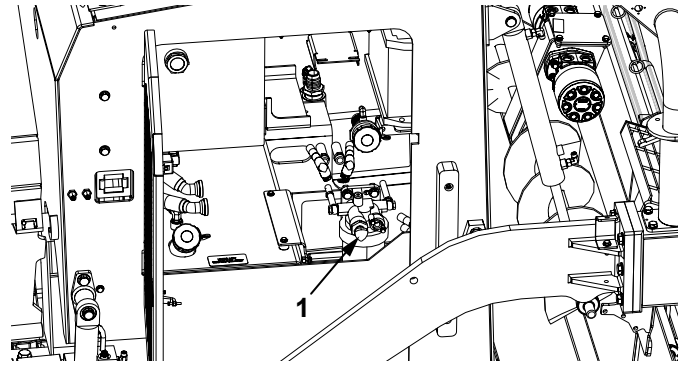

3.17 Paver Shutdown

1. Park paver on firm level surface.
2. Lower screed to ground.
3. Close hoppers.
4. Turn engine off and remove ignition key.

3.18 Drive Disconnect

If paver is disabled and must be towed to a safe location, use the following procedure to disengage paver drive.

1. Turn engine off, remove ignition key and place a Do Not Operate tag on ignition switch.
2. Remove cap screw (1).
3. Loosen cap screw (2).

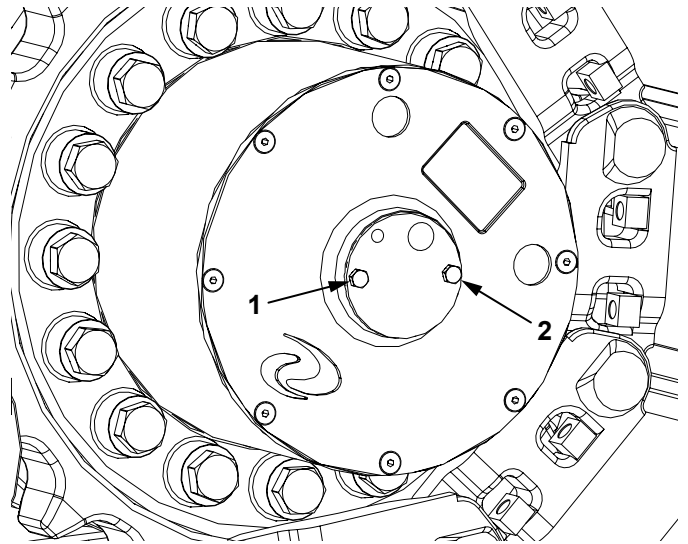

4. Rotate end cover (3) until large hole is over center of hub and hole (4) is over threaded hole.

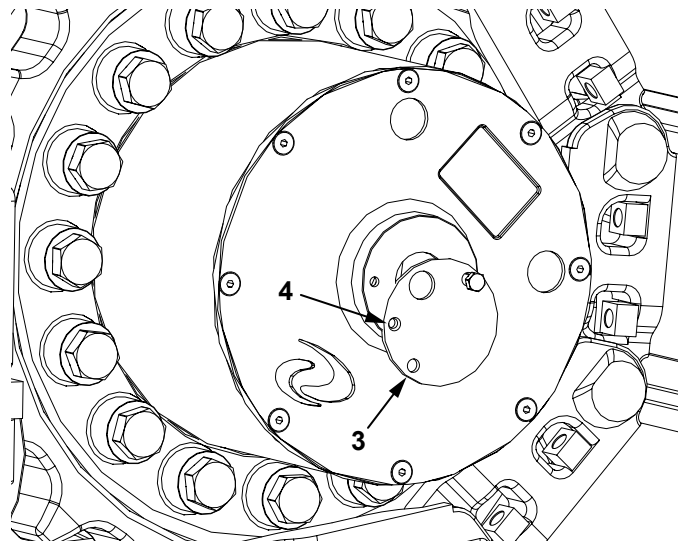

5. Pull fast sun gear (5) out using and cap screw removed in step 1.

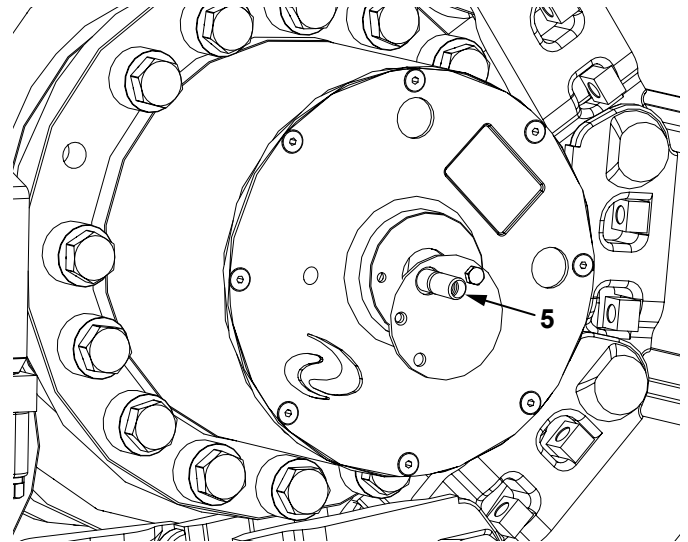

6. Remove cap screw (1) from sun gear and install into housing as shown.
7. Repeat procedure for planetary on other side.
8. Drive system is now disengaged.
9. Reverse procedure to engage drive system.

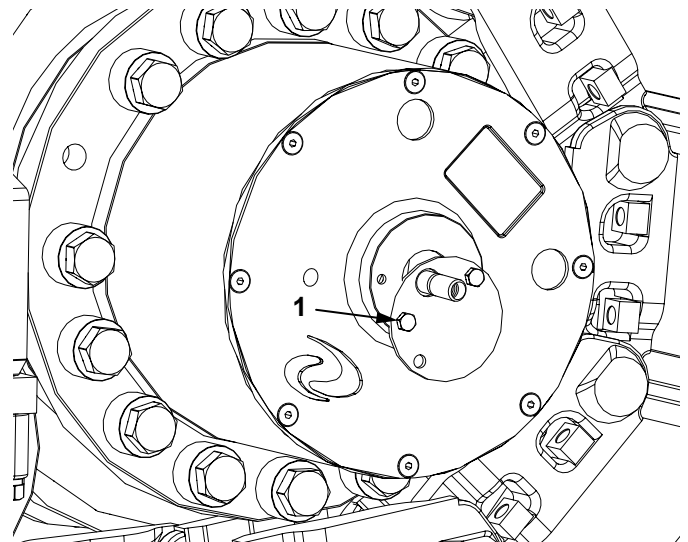

4. Material Feed

4.1 Automatic Material Feed Operation

Single Operator Feed Setup

Active operators station controls all feed systems. Both operator stations can control hopper screed and extensions at any time regardless if dual or single mode is selected.

At active operators station:

1. Select single on feed control screen on digital display.
2. Move left hand auger switch (1) to auto position.
3. Move left hand auger direction switch (2) to out ◀ position.
4. Move left hand conveyor switch (3) to auto position. Left hand auger icon should be illuminated.
5. Move right hand auger switch (4) to auto position.
6. Move right hand auger direction switch (5) to out ▶ position.
7. Move right hand conveyor switch (6) auto position. Right hand auger icon should be illuminated.

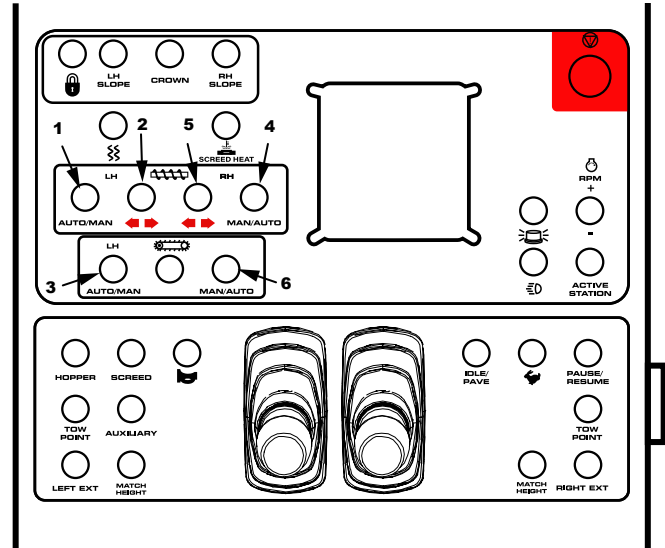

Dual Operator Feed Setup

Left hand operators station controls left hand feed systems. Right hand operators station controls right hand feed system. Both operator stations control hopper, screed and extension functions.

1. Select dual operators on digital display.

At left hand operators station:

2. Move left hand auger switch (1) to auto position.
3. Move left hand auger direction switch (2) to out ◀ position.
4. Move left hand conveyor switch (3) to auto position. Left hand auger icon should be illuminated.

At right hand operators station:

5. Move right hand auger switch (4) to auto position.
6. Move right hand auger direction switch (5) to out ▶ position.
7. Move right hand conveyor switch (6) auto position. Right hand auger icon should be illuminated.

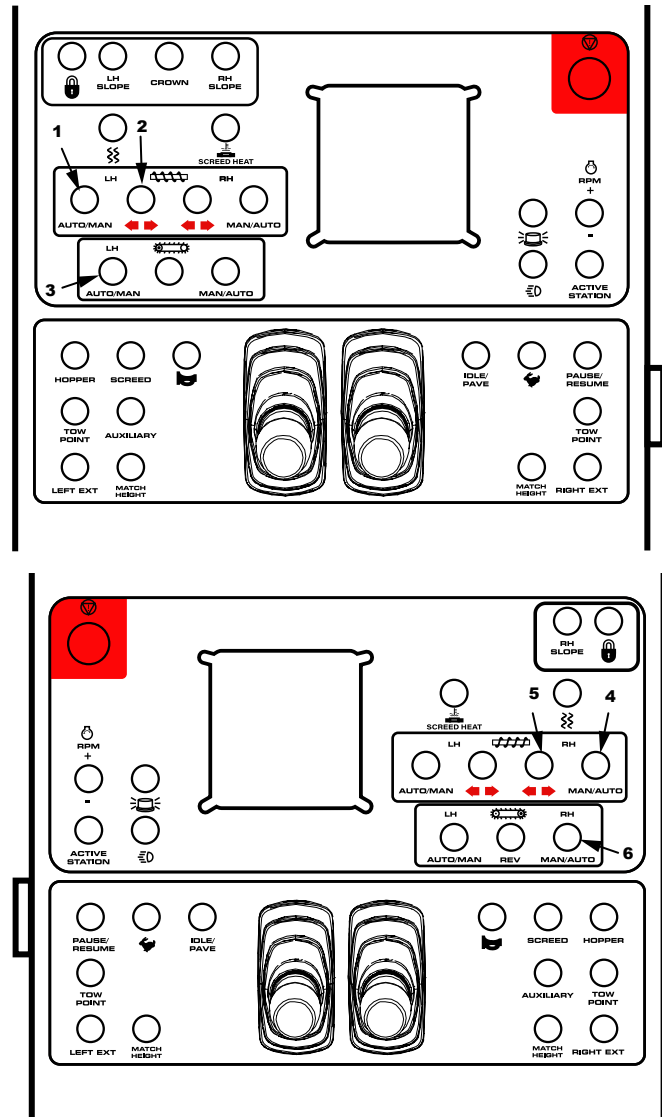

4.2 Manual Material Feed Operation

Operators less familiar with automatic feeding controls may want to use the manual mode for the first several hours of operation to become familiar with the other controls and operation.

Single Operator Feed Setup

Left hand operators station controls all feed systems.

At left hand operators station:

1. With left hand operator station as the active station, select single feed mode.
2. Move left hand auger switch (1) to manual position.
3. Move left hand auger direction switch (2) to out ◀ position.
4. Move left hand conveyor switch (3) to auto position.
5. Move right hand auger switch (4) to manual position.
6. Move right hand auger direction switch (5) to out ▶ position.
7. Move right hand conveyor switch (6) auto position.

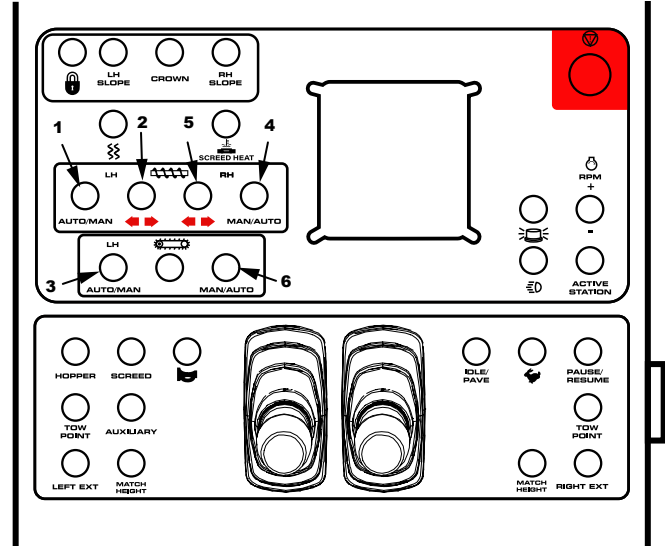

Dual Operator Feed Setup

Right hand operators station controls all feed systems.

At right hand operators station:

1. With right hand operator station as the active station, select single feed mode.
2. Move left hand auger switch (1) to manual position.
3. Move left hand auger direction switch (2) to out ◀ position.
4. Move left hand conveyor switch (3) auto position.
5. Move right hand auger switch (4) to manual position.
6. Move right hand auger direction switch (5) to out ▶ position.
7. Move right hand conveyor switch (6) auto position.

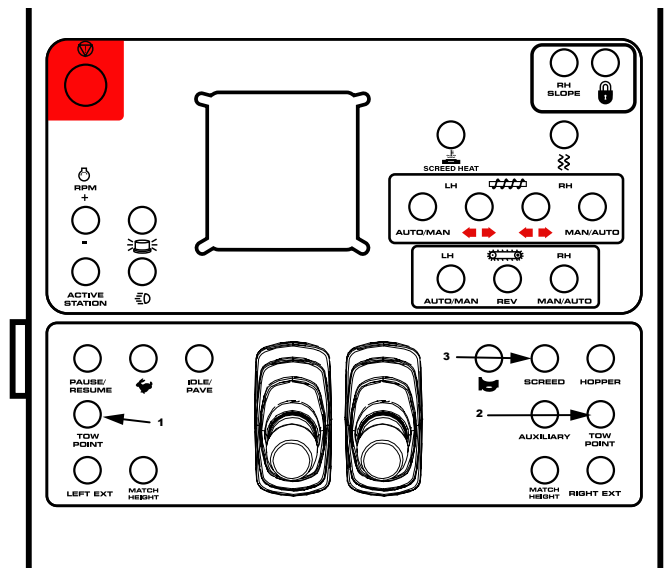

4.3 Sonic Sensors

The automatic material feed system uses sonic sensors (1). Sonic sensing will allow you to maintain the amount of material that you prefer on the end of the extension, regardless of adverse paving conditions.

The sonic sensors are installed in holders on the screed end gate. Before going any further make sure you have followed one of the Automatic Material Feed Operation setups.

Toggle display to feed control screen. Press material height button to select low for material height below auger, medium for material height level with auger, or high for material height above auger.

If sonic sensor bracket has been inadvertently repositioned, sensor may pick up a reading from the auger flighting, or from the back of the tractor. If this is occurring, remove sensor from bracket and try to identify what is the obstruction. Direction of the bracket may need to be repositioned away from the obstruction.

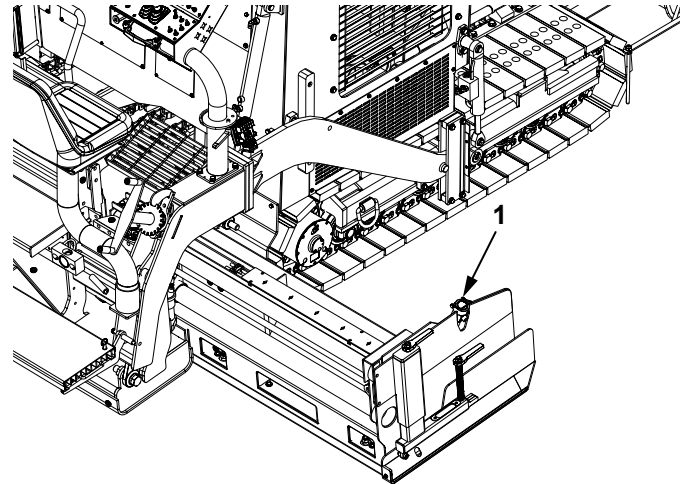

4.4 Screed Heating System

The screed has heating elements in the main screed and on each extension. Heating system is thermostatically controlled. Generator will cycle on/off as needed to keep screed at selected temperature. The factory recommended setting is 230°F (110°C). There is only one temperature setpoint for all heating elements. If the mat streaks when paving starts, raise the set point 10 degrees at a time until streaking is eliminated. Use the following procedure to set the screed heat set point.

1. Start paver engine. See Section 3.4 Start Engine.
2. Verify extensions are in the closed position. Lower the screed onto hot asphalt or 1 in. (25 mm) from the ground. Heating screed on a cold surface will increase pre-heat time.
3. Toggle generator switch (1) to on position to activate the heating system. The default temperature is 230°F.

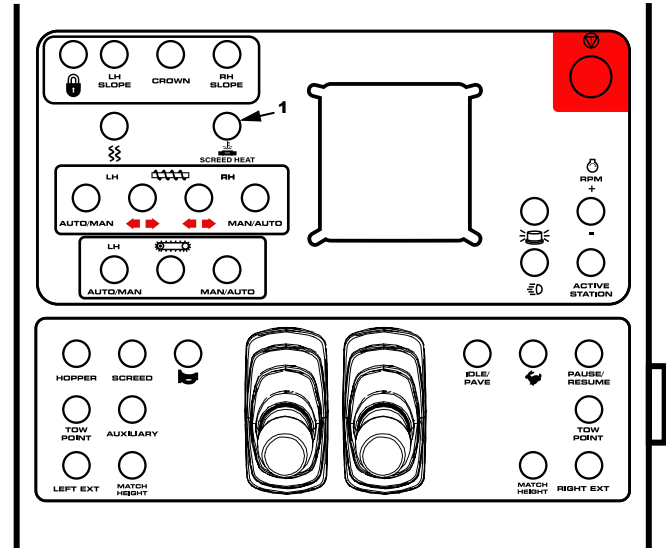

4. Press button (2) to decrease set point, or button (3) to increase setpoint. Each press of the button will change setpoint by 10°F.

Press and hold button (4) to display icon legend (5). The left, main and right screed indicators will display one of the following icons:

- Green Circle - Temperature within 10°F of set point
- Orange Triangle - Setpoint temperature has not been reached.
- Grey Diamond - Heating system is off.
- Red Square - Heating system fault.

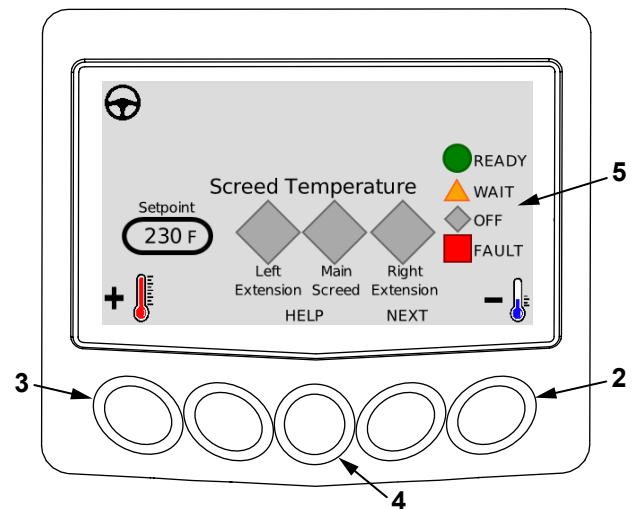

5. Paver will continually monitor the four heat zone temperatures and supply heat to any zone that falls below the pre-set temperature.
6. To turn the heat off, toggle generator switch (1) to off position.

5. Screed Setup

5.1 Crown Setting

1. Start paver engine. See Section 3.4 Start Engine.
2. Toggle tow point switches (1) and (2) to expose an equal amount of the cylinder rod on each cylinder.
3. Toggle screed switch (3) to lower screed onto a flat surface.

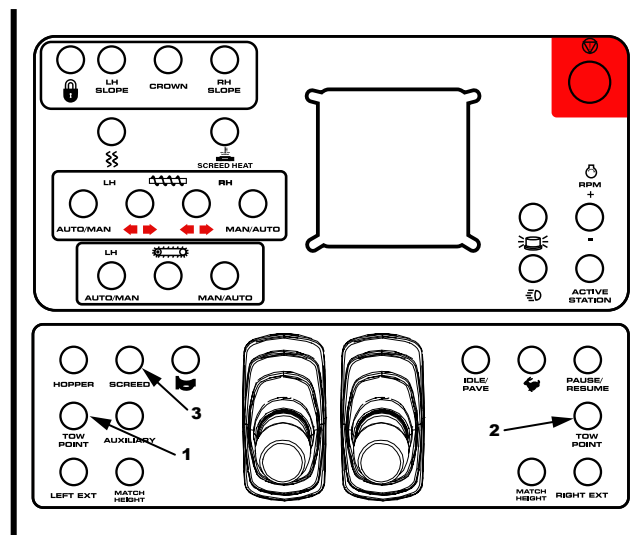

4. Rotate screed depth handles (4) until they are free and not in tension.

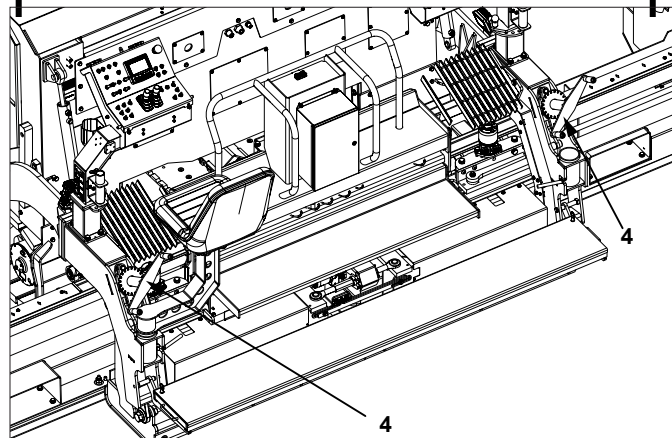

WARNING

Crush hazard.

A raised screed may lower unexpectedly.

Engage screed support locks to support screed.

Do not place any part of body under screed.

5. Fully raise screed and engage support locks (5) as shown on each side of paver.
6. Lower screed until screed arms are resting on support locks.

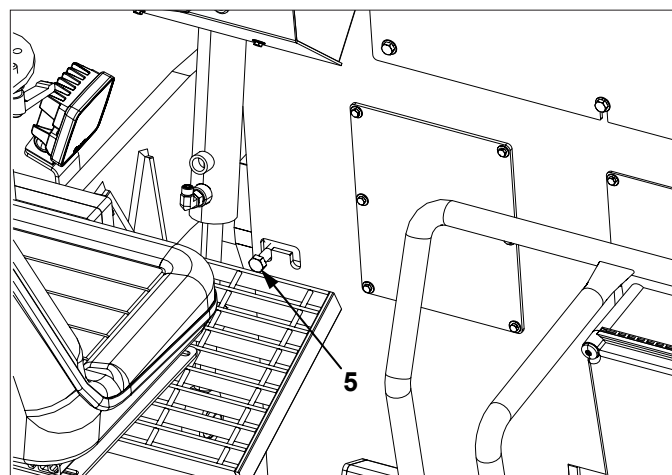

WARNING

Crush hazard.

Paver can be inadvertently started and moved.

Stop engine, remove key and place a Do Not Operate tag on ignition switch.

7. Stop paver engine, remove key and place a Do Not Operate tag on ignition switch.

8. Flip middle walk board up.

9. Disengage three spring latch pins (6). Disengaging pins will allow front (7) and rear (8) crown adjustments shafts to be turned independently of each other.

10. Hook or wrap one end of a string on a large bolt head on one end of main screed. Walk to other end of screed and position string across leading edge (9) of main screed bottom, as close as possible to the bullnose of the screed plate. Hook end of string to a large bolt head and pull tight. String MUST be on flat portion of screed, not on radius portion.

11. Rotate forward crown adjustment shaft (7) until there is approximately 1/16 in. (1.6 mm) gap between center of screed plate and the string. Pull string away at one end, and bring it back to verify 1/16 in. (1.6 mm) dimension at center of screed.

12. Place another string across trailing edge (10) of main screed bottom, near rear curvature of screed plate.

13. Rotate rear crown adjustment shaft (8) until screed plate just touches the whole length of the string. Pull the string away at one end and bring it back to verify that it contacts entire length at the same time.

14. Recheck gap between leading edge (9) of screed bottom and string. Adjust forward ratchet jack as necessary to obtain the 1/16 in (1.6 mm) gap between string and screed plate.

15. Recheck gap between trailing edge of screed bottom and string. Adjust rear ratchet jack as necessary to verify screed plate just touches whole length of string.

16. Engage three spring pins (6). It may be necessary to turn rear crown adjustment shaft to get pins and holes to align, but no more than 1/3 of a turn.

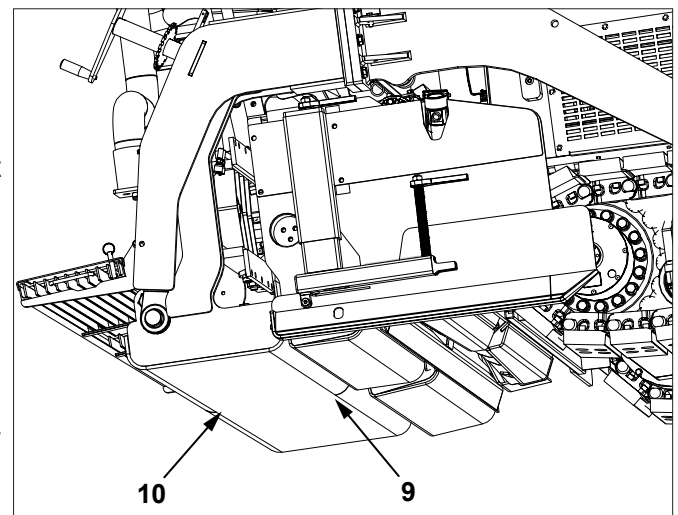
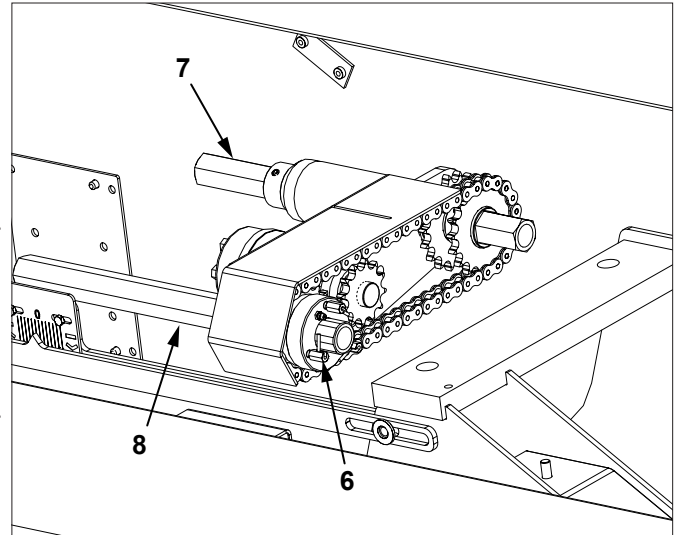

5.2 Extension Setting

5.2.1 Prepare Paver For Screed Adjustments

1. Start paver engine. See Section 3.4 Start Engine.

⚠ WARNING

Crush hazard.

A raised screed may lower unexpectedly.

Engage screed support locks to support screed.

Do not place any part of body under any part of screed.

2. Fully raise screed and engage support locks (1) as shown on each side of paver.
3. Lower screed until screed arms are resting on support locks.
4. Fully retract screed extensions.

⚠ WARNING

Crush hazard.

Paver can be inadvertently started and moved.

Stop engine, remove key and place a Do Not Operate tag on ignition switch.

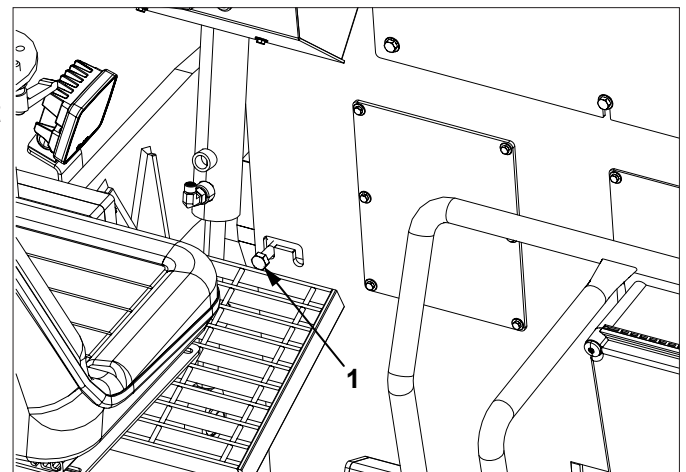

5. Stop paver engine, remove key and place a Do Not Operate tag on ignition switch.

5.2.2 Set Match Height

1. With paver engine running, adjust screed extension match height until extension screed plate trailing edge (2) just touches straight edge (3) held against the bottom of main screed (4) at the outside edge.
2. Prepare paver for screed adjustments. See Section 5.2.1 Prepare Paver For Screed Adjustments.

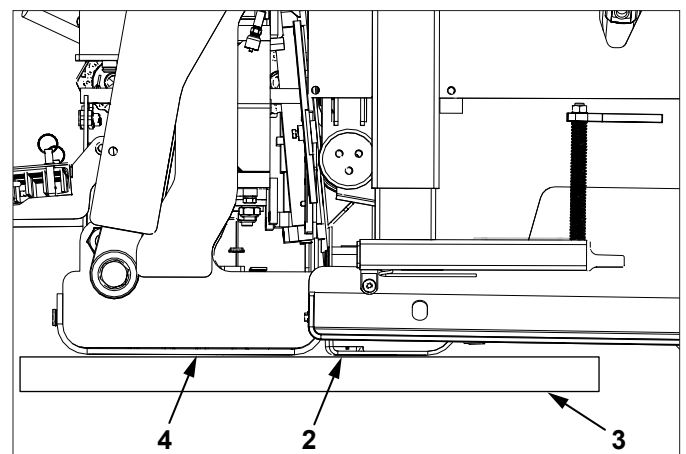

3. With screed extensions retracted, run a string across the entire trailing edge (5) of the screed extension bottoms.

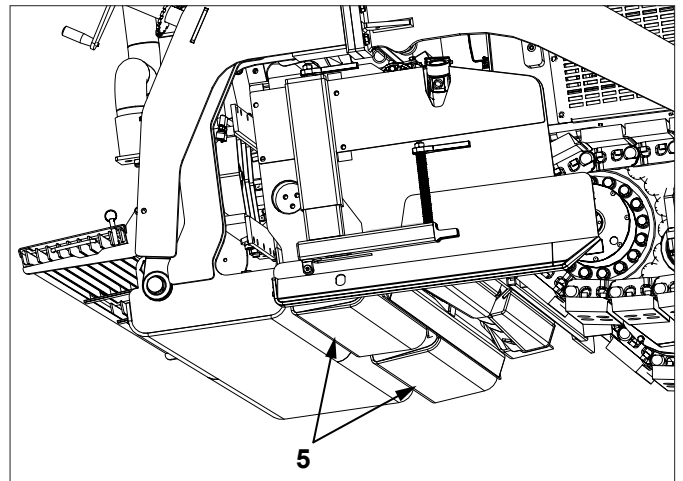

5.2.3 Set Extension Slope

1. Prepare paver for screed adjustments. See Section 5.2.1 Prepare Paver For Screed Adjustments.
2. Adjust slope ratchet style handles (6) until screed extension bottoms are above string on both sides, looking at the inboard edge of the extension bottoms.
3. Reverse direction on slope ratchet handles and lower the inboard edges until they are just contacting the string.

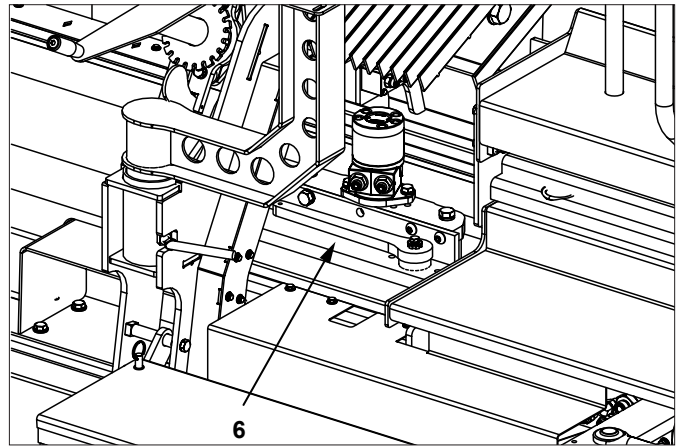

5.2.4 Set Extension Bottom Angle Of Attack

1. Prepare paver for screed adjustments. See Section 5.2.1 Prepare Paver For Screed Adjustments.
2. The extension angle of attack measurement (7) should be originally set at 0.25 in (6.5 mm) above the straight edge (3). Make first measurement with extension fully retracted, then second measurement with extension fully extended.
3. Fully extend extension.

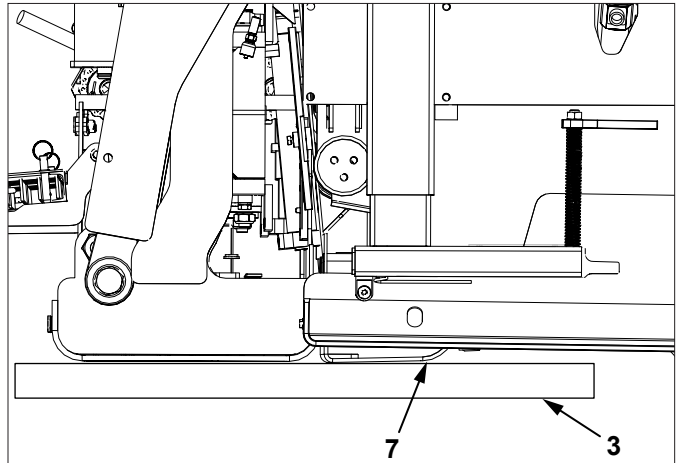

4. Loosen jam nuts and turn adjusters (8) clockwise to increased angle or counter clockwise to decrease angle.
5. Tighten jam nuts.
6. Verify measurement, adjust if needed.

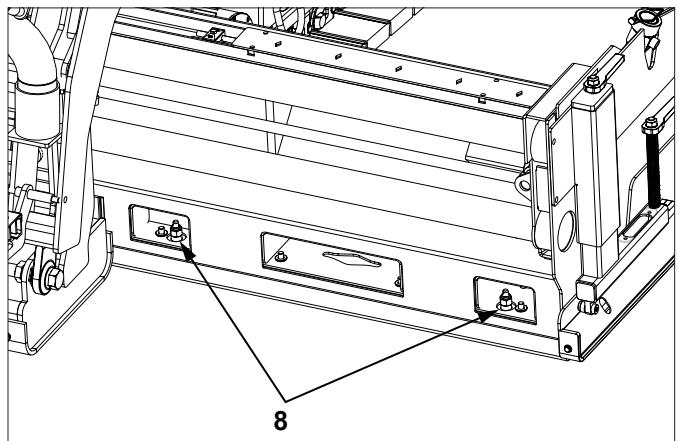

5.3 Pre-Strike Off Setting

1. Start paver engine. See Section 3.4 Start Engine.

⚠ WARNING

Crush hazard.

A raised screed may lower unexpectedly.

Engage screed support locks to support screed.

Do not place any part of body under any part of screed.

2. Fully raise screed and engage support locks (1) as shown on each side of paver.
3. Lower screed until screed arms are resting on support locks.
4. Fully retract screed extensions.

⚠ WARNING

Crush hazard.

Paver can be inadvertently started and moved.

Stop engine, remove key and place a Do Not Operate tag on ignition switch.

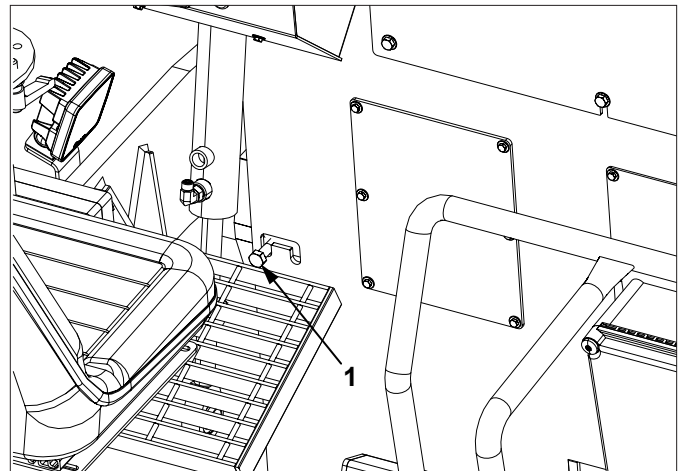

5. Stop paver engine, remove key and place a Do Not Operate tag on ignition switch.
6. Extension setting must be completed before attempting to set pre-strike off.
7. Position straight edge (2) 12 in. (305 mm) from outer edge of main screed plate.
8. Measure distance (3) between pre-strike off and straight edge. Both sides of pre-strike off are vertically adjustable. Measure 12 in. (305 mm) from right hand edge and another measurement 12 in. (305 mm) from left hand edge. Gap between straight edge and bottom of pre-strike off should be 0.75 in. (19 mm) minimum to 1 in. (25 mm) maximum. For lifts of 5 - 6 in. (127 - 152 mm) this setting may need to be increased.

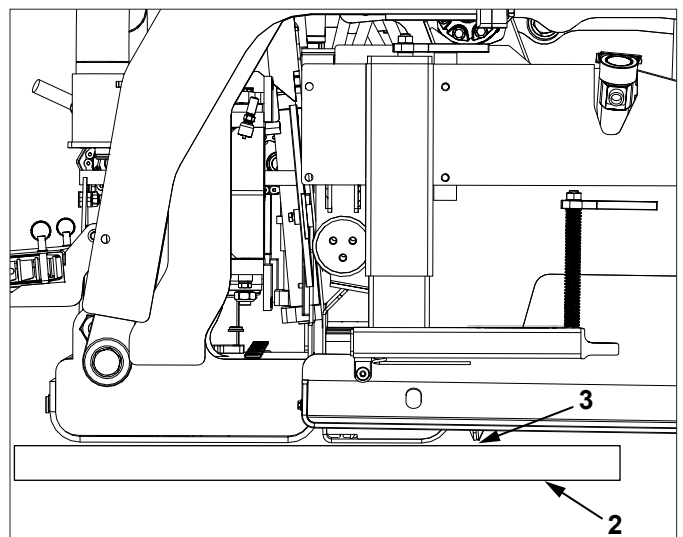

9. Start paver engine, disengage screed support locks and fully extend both extensions. Slowly lower screed onto a block that has been placed directly under pre-strike off. From top side you will be able to see pre-strike off mount ride up in its slotted mounting on either side of the top walk board. As soon as you see this slotted mount is visible, stop lowering screed.

10. Raise center walk board (4) exposing the cam style adjustment (5) for each side. Loosen jam nut on locator bolt and fully remove the locator bolt. Rotate the cam bolt clockwise to raise pre-strike off. Install locator bolt and tighten jam nut.

From this initial factory screed setting you will need to make a match height adjustment in the down direction when you start paving.

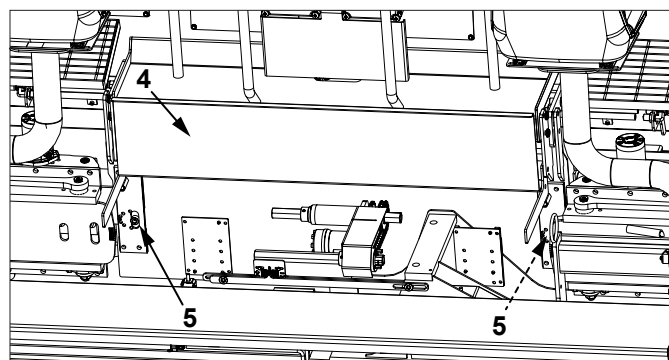

5.4 Setting Screed To Pave

The procedure in sections 5.1, 5.2 and 5.3 was set before leaving the factory. It is recommended that before initial start up, follow procedure in these sections to verify settings.

5.4.1 Before Paving

Screed must be elevated a distance equal to the desired mat depth plus enough extra height to allow for compaction. To achieve this, the most popular methods are starting blocks or an asphalt pad

- Starting Blocks – A 2.5 in. (63.5 mm) thick starting block is a good for a finished mat of 2 in. (51 mm).
- Compacted Asphalt Pad – A starting block equal to the amount of compaction will be required.
- Non-Compacted Asphalt Pad – Lower the screed fully onto pad, no starting block required.

Starting blocks should be at least as long as the front to rear dimension of the screed plate. They should be placed lengthwise in the direction of travel, directly below screed depth cranks.

5.4.2 Nulling The Screed And Setting Angle Of Attack

This is adjustment of the screed to a perfectly flat position on either starting blocks or an asphalt pad.

⚠ WARNING

Crush hazard.

Do not place any part of body under screed.

1. Lower screed completely onto starting surface, blocks or pads.
2. Rotate adjustment crank handles (1) to locate position of free movement. This is a limited area where adjustment cranks rotate freely in either direction. This is the nulled position.
3. Rotate adjustment crank handles (1) two full clockwise rotations to set center screed.
4. Start paving and make adjustments as required.

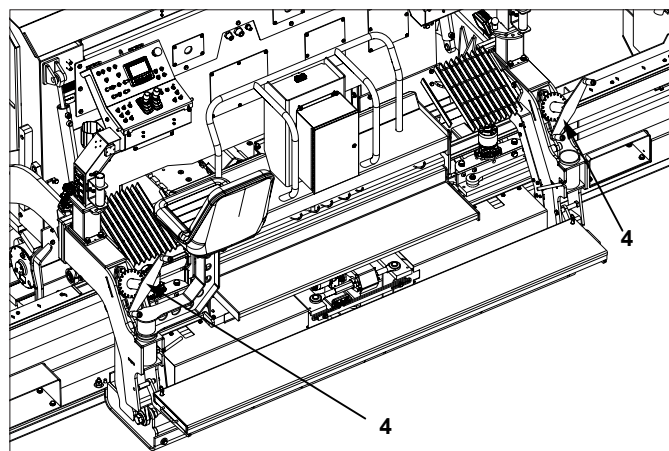

6. Inspections And Maintenance

6.1 Inspection And Maintenance Chart

Item	Daily Before Use	Daily After Use	Initial 50 Hrs	Initial 100 Hrs	Monthly/ 250 Hrs	Yearly/ 500 Hrs	5 Year/ 5000 Hrs
Check engine oil and coolant level.	•						
Check fuel and DEF levels.	•						
Check hydraulic oil level.	•						
Check operation of all lights.	•						
Check operation of horn and signal devices.	•						
Check that all safety decals are legible.	•						
Inspect air intake system and service indicator.	•						
Inspect radiator fins for debris.	•						
Drain fuel/water separator	•						
Grease Crown Adjustment					•		
Clean residue from paver.		•					
Wash paver.		•					
Change hydraulic filter.			•				
Change engine oil and filter.			•				
Inspect conveyor chain.					•		
Change engine oil and filter.					•		
Change hydraulic oil and filter						•	
Change engine coolant.						•	
Change engine fuel filters.						•	
Change engine air filter.						•	
Clean radiator fins.						•	
Clean battery terminals and cable connections.						•	
Change Planetary Gear Fluid				•		•	
Grease Conveyor Drive Shaft Bearings							•

6.1.1 Fluid Capacities

Fluid	Capacity	Recommendation
Engine Oil	11 Qt	15W-40
Hydraulic Oil	30 Gal	AW 46
Coolant	7 Gal	Extended Life
Grease	As Needed	NLGI Grade 2
Diesel	22 Gal	Low Sulfur Diesel
Planetary Drive	.75 Qt*	80W90
Conveyor Drive	1.7Qt	85W-140

*Estimated, please follow proper fill instructions.

6.2 Prepare Paver For Inspections And Maintenance

WARNING

Entanglement and crush hazard.

Keep all personnel clear of augers, conveyors and other rotating shafts when engine is running or about to be started.

Verify all guards are in place.

Follow lockout/tagout procedure before performing inspections or maintenance.

Before performing inspections, service or maintenance:
Park paver on firm level surface.
Lower screed to ground or engage screed support locks.
Fully open or close hoppers.
Turn engine off and remove ignition key.
Attach a Do Not Operate tag or similar warning tag to the ignition switch.
Follow lockout/tag out procedure as defined by your company.

After performing inspections, service or maintenance, verify all guards have been reinstalled and all safety devices are functional.

Wear personal protective equipment appropriate for the task.

Use Mauldin replacement parts.

6.3 Daily Before Use

6.3.1 Check Engine Oil Level

Prepare paver for inspections and maintenance. See Section 6.2 Prepare For Inspections And Maintenance.
Push dipstick down fully and pull out. If oil level is below add mark, add proper grade and viscosity of oil through filler tube to raise oil level to full mark. Do not overfill. Refer to engine OEM manual for oil specifications.

6.3.2 Check Engine Coolant Level

⚠ WARNING

Hot pressurized liquid.

Burn hazard.

Do not remove cap when hot.

NOTICE

Do not add coolant to a hot engine. Engine can be damaged.

Check engine coolant level in sight glass. Coolant must be visible in sight glass. Add coolant if necessary. Refer to OEM engine manufacturers' manual for coolant specifications.

6.3.3 Check Engine Fuel And DEF Levels

⚠ WARNING

Breathing diesel engine exhaust exposes you to chemicals known to the State of California to cause cancer and birth defects or other reproductive harm.

- Always start and operate the engine in a well-ventilated area.
- If in an enclosed area, vent the exhaust to the outside.
- Do not modify or tamper with the exhaust system.
- Do not idle the engine except as necessary.

For more information go to www.P65Warnings.ca.gov/diesel

⚠ WARNING

Diesel exhaust fluid (DEF) hazard.

In case of contact with eyes, immediately flush eyes with water. Obtain medical attention immediately.

In case of skin contact, wash all exposed skin area with mild soap and water, followed by warm water rinse.

If ingested, obtain medical attention immediately.

NOTICE

Prevent equipment damage.

Adding chemicals/additives to the diesel exhaust fluid may damage the aftertreatment system.

1. Prepare paver for inspections and maintenance. See Section 6.2 Prepare For Inspections And Maintenance.
2. Check fuel tank gauge and DEF tank gauge on digital display engine page.

6.3.4 Check Hydraulic Oil Level

1. Prepare paver for inspections and maintenance. See Section 6.2 Prepare For Inspections And Maintenance.
2. Hydraulic oil level must be visible in sight gauge (1) with engine stopped.
3. Add proper hydraulic oil if necessary.

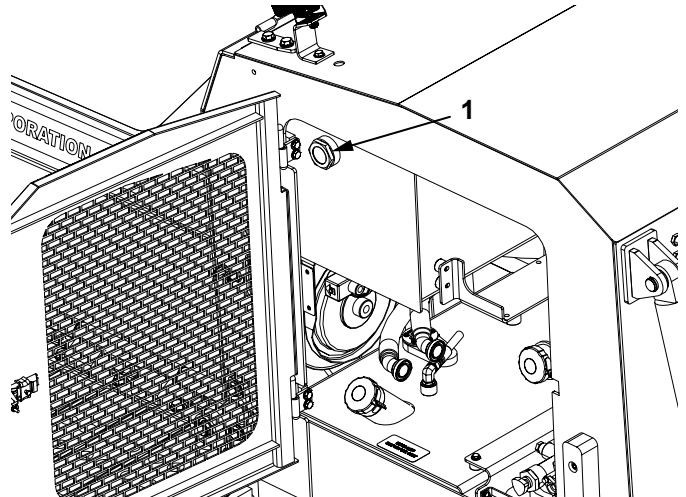

6.3.5 Verify Lights Are Operable

Verify that all lights installed on paver are operational. Do not operate if any lights are not operational.

6.3.6 Check Horn And Signal Devices

Verify horn is operational. Both operator stations are equipped with a horn switch.

Check operation of the backup alarm.

6.3.7 Check Safety Decals

All safety decals are in place and legible. If the safety decal is no longer legible, replace it with a new one. Contact your dealer for new decals.

6.3.8 Check Engine Radiator Intake Screen

1. Prepare paver for inspections and maintenance. See Section 6.2 Prepare For Inspections And Maintenance.
2. Check engine radiator intake screen for dirt and debris. Clean with low pressure compressed air or spray wash if required.

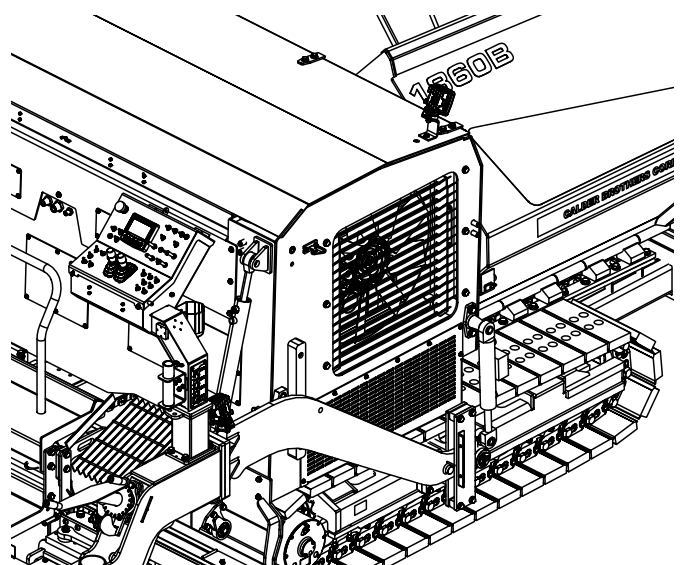

6.3.9 Drain Fuel/Water Separator

1. Prepare paver for inspections and maintenance. See Section 6.2 Prepare For Inspections And Maintenance.
2. Wear personal protective equipment appropriate for the task.
3. Drain fuel/water separator (1) into a suitable container. Dispose of fuel/water in an environmentally safe manner.

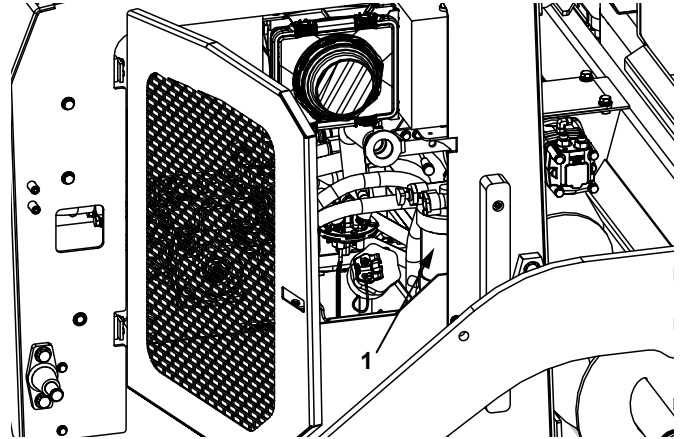

6.4 Daily After Use

1. 6.4.1 Clean Residue After Use Prepare paver for inspections and maintenance. See Section 6.2 Prepare For Inspections And Maintenance.
2. Wear personal protective equipment appropriate for the task.
3. Clean conveyor, augers and screed at end of each days use with on-board wash system.

6.4.2 Wash Paver

1. Prepare paver for inspections and maintenance. See Section 6.2 Prepare For Inspections And Maintenance.
2. Wear personal protective equipment appropriate for the task.
3. Wash paver as necessary to remove dust and dirt.

6.5 After Initial 50 Hours

6.5.1 Change Hydraulic Filters

1. Prepare paver for inspections and maintenance. See Section 6.2 Prepare For Inspections And Maintenance.
2. Wear personal protective equipment appropriate for the task.
3. Place catch pan under filter.
4. Remove and replace spin on filter (1) and filter (2).
5. Check hydraulic oil level in sight glass (3). Add hydraulic oil if necessary.
6. Dispose of hydraulic oil in an environmentally safe manner.

6.5.2 Change Engine Oil And Oil Filter

1. See OEM engine operators manual for oil and filter specification.
2. Fully open hopper doors.
3. Prepare paver for inspections and maintenance. See Section 6.2 Prepare For Inspections And Maintenance.
4. Wear personal protective equipment appropriate for the task.
5. Allow engine and surrounding parts to cool before proceeding.
6. Position an adequate drain pan under plug (1).
7. Remove plug (1) to drain engine oil. Install plug after all oil has drained.
8. Remove cover (2) to access engine oil filters.
9. Remove and discard existing oil filter.
10. Fill new filter with clean engine oil.
11. Lightly coat filter sealing ring with oil.
12. Install filter until seals contacts flange. Tighten an additional 1/2 - 3/4 turn by hand. Do not over tighten.
13. Fill crankcase to correct level.
14. Start engine and run at low idle.
15. Stop engine and check for leaks.
16. Check engine oil level.
17. Install cover (2).
18. Dispose of oil and filter in an environmentally safe manner.

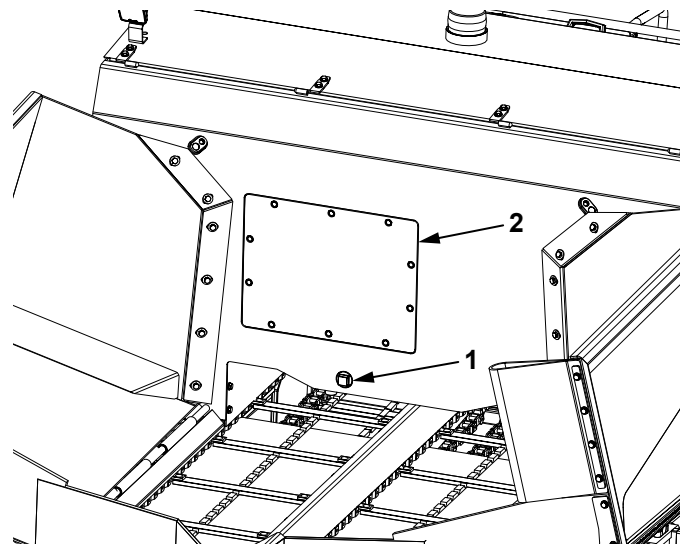

6.6 Monthly / Every 250 Hours

6.6.1 Inspect Conveyor And Drive System

1. Prepare paver for inspections and maintenance. See Section 6.2 Prepare For Inspections And Maintenance.
2. Wear personal protective equipment appropriate for the task.
3. Check for worn sprockets and chain.
4. Check keys and keyways for wear. Replace keys if needed.
5. Tighten conveyor chains with slack adjusters (1) mounted to the underside of the conveyor. Tighten until the chains pull up to within 8 in. (203 mm) of the underside of the conveyor deck. Measurement should be made from the peak of the arc in the chains. Do not over tighten.

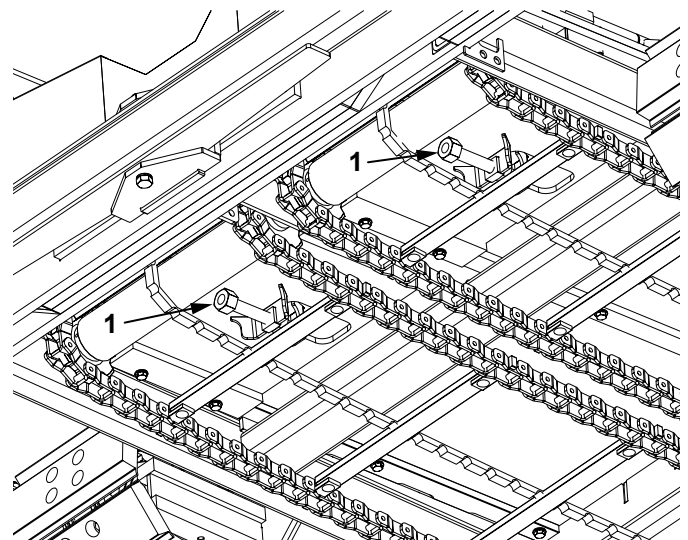

6.6.2 Change Engine Oil And Oil Filter

1. See OEM engine operators manual for oil and filter specifications.
2. Fully open hopper doors.
3. Prepare paver for inspections and maintenance. See Section 6.2 Prepare For Inspections And Maintenance.
4. Wear personal protective equipment appropriate for the task.
5. Allow engine and surrounding parts to cool before proceeding.
6. Position an adequate drain pan under plug (1).
7. Remove plug (1) to drain engine oil. Install plug after all oil has drained.
8. Remove cover (2) to access engine oil filters.
9. Remove and discard existing oil filter.
10. Fill new filter with clean engine oil.
11. Lightly coat filter sealing ring with oil.
12. Install filter until seals contacts flange. Tighten an additional 1/2 - 3/4 turn by hand. Do not over tighten.
13. Fill crankcase to correct level.
14. Start engine and run at low idle.
15. Stop engine, remove key and attach a Do Not Operate tag or similar warning tag to ignition switch.
16. Check engine oil level and check for leaks.
17. Install cover (2).
18. Dispose of oil and filter in an environmentally safe manner.

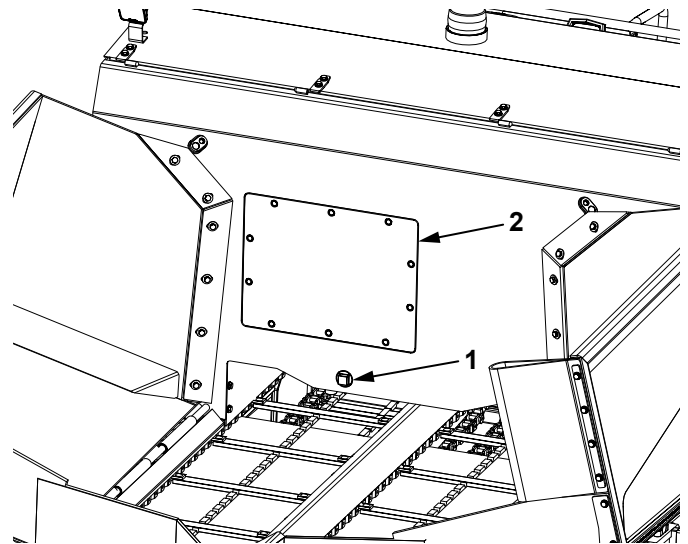

6.7 Yearly / 500 Hours

6.7.1 Change Hydraulic Oil And Filters

1. Prepare paver for inspections and maintenance. See Section 6.2 Prepare For Inspections And Maintenance.
2. Wear personal protective equipment appropriate for the task.
3. Place catch pan under filter.
4. Remove and replace spin on filter (1) and filter (2).
5. Pump hydraulic oil out of reservoir fill cap with a transfer pump.
6. Remove drain plug (A) and drain hydraulic oil into a suitable container. Install plug after draining.
7. Add new hydraulic oil to reservoir until oil is visible in sight glass (3).
8. Start engine and safely operate hydraulics. Stop engine

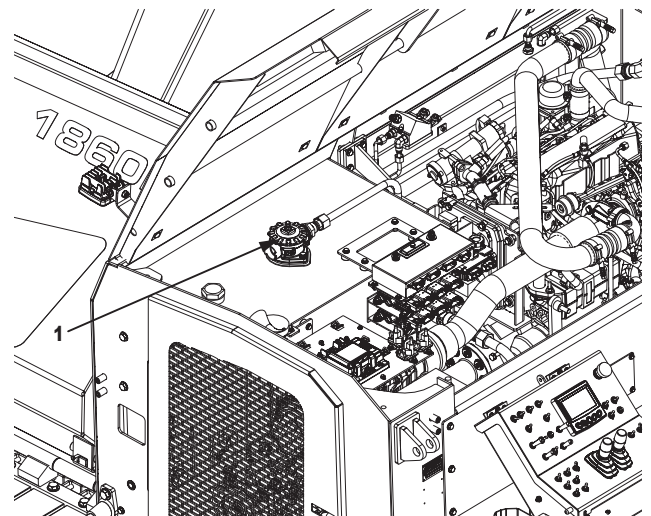

and check hydraulic oil level. Add hydraulic oil if necessary.

9. Dispose of hydraulic oil in an environmentally safe manner.

6.7.2 Change Engine Coolant

1. Prepare paver for inspections and maintenance. See Section 6.2 Prepare For Inspections And Maintenance.
2. Wear personal protective equipment appropriate for the task.
3. Refer to OEM engine manufacturers' manual for coolant specifications.
4. To change coolant first be sure engine is cool then drain coolant completely. Drain valve is located at bottom of radiator.
5. Remove radiator cap and add coolant until full. Install cap and close access door.

6.7.3 Change Engine Fuel Filters

1. Prepare paver for inspections and maintenance. See Section 6.2 Prepare For Inspections And Maintenance.
2. Wear personal protective equipment appropriate for the task.
3. Refer to OEM engine manufacturers' manual for fuel filter specifications.
4. Both filters can be reached from the left side access door.
5. Remove fuel filter and fuel/water separator.
6. Add clean fuel to new filters.
7. Install each filter until seal contacts flange. Tighten an additional 1/2 to 3/4 turn by hand. Do not over tighten.

6.5.4 Change Engine Air Filter

1. Prepare paver for inspections and maintenance. See Section 6.2 Prepare For Inspections And Maintenance.
2. Wear personal protective equipment appropriate for the task.
3. Refer to OEM engine manufacturers' manual for air filter specifications.
4. Open air filter housing and remove filter element.
5. Clean inside of housing and end cap with a damp rag.
6. Insert new filter element and install end cap.

6.7.5 Clean Engine Radiator Fins And Screen

1. Prepare paver for inspections and maintenance. See Section 6.2 Prepare For Inspections And Maintenance.
2. Wear personal protective equipment appropriate for the task.
3. Check engine radiator fins and intake screen and for dirt and debris. Clean with low pressure compressed air or spray wash if required.

6.7.6 Battery

 **WARNING**

Batteries, battery posts, battery terminals, and related accessories can expose you to chemicals including lead and lead compounds, which are known to the State of California to cause cancer and birth defects or other reproductive harm.

⚠ WARNING

Avoid injury. Battery electrolyte contains sulfuric acid. It is poisonous and can cause serious burns.

- **Wear eye protection and gloves.**
- **Keep skin protected.**
- **If electrolyte is swallowed, get medical attention immediately.**
- **If electrolyte is splashed into eyes, flush immediately with water for 15-30 minutes and get medical attention.**
- **If electrolyte is splashed onto skin, flush immediately with water and get medical attention if necessary.**

⚠ WARNING

The battery produces a flammable and explosive gas.

- **Do not smoke near battery.**
 - **Do not allow direct metal contact across battery posts.**
 - **Remove negative cable first when disconnecting.**
 - **Install negative cable last when connecting.**
1. Prepare paver for inspections and maintenance. See Section 6.2 Prepare For Inspections And Maintenance.
 2. Wear personal protective equipment appropriate for the task.
 3. Disconnect negative (-) cable from battery terminal.
 4. Disconnect positive (+) cable from battery terminal.
 5. Thoroughly clean terminals with a battery cleaning tool.
 6. Connect positive (+) cable to positive battery terminal.
 7. Connect negative (-) cable to negative battery terminal.

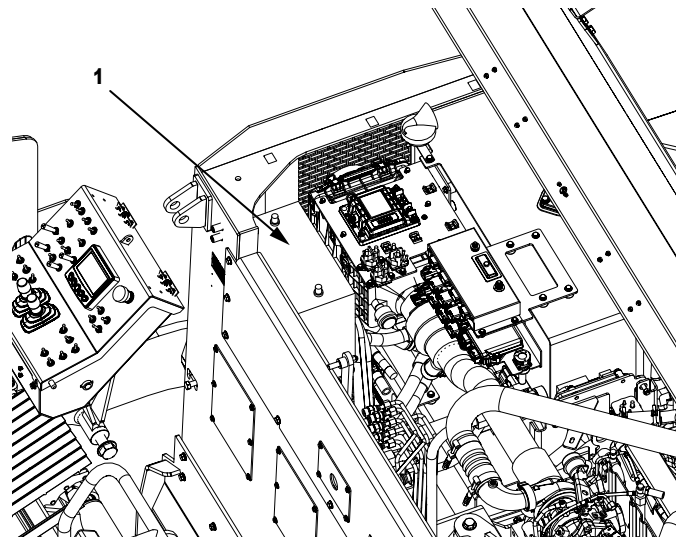

6.7.7 Fill/Drain Planetary Fluid

To Replace Planetary Fluid

1. Rotate the planetary so the Fill/Drain Hole (1) is in the 6 o'clock position.
2. The fluid level hole (2) will be in the 9 o'clock position.
3. Unscrew the plug from the Fill./Drain Hole (1), and drain all of the fluid.
4. Once the Planetary is completely drained rotate the

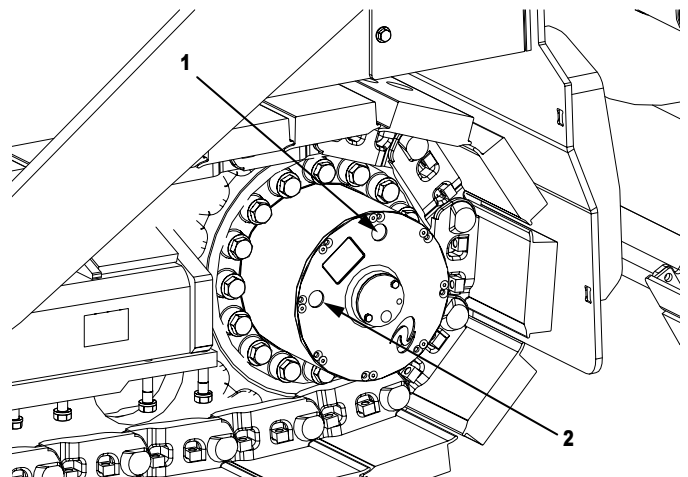

planetary until the fluid level hole (2) is at the 3 o'clock position, and Fill/drain hole (1) will be at the 12 o'clock position.

5. Remove the plug from the Fluid level hole (2).
6. Pour Fluid into the Fill hole (1) until fluid starts to come out of the fluid level hole (2). Use only 80w90 Gear oil.
7. Replace both plugs and tighten.

7. Troubleshooting

7.1. General

WARNING

If you must troubleshoot machine with engine running, have someone in constant visual contact who can shut off the engine or engage an emergency stop.

WARNING

Crush hazard.

A raised screed or partially open hopper will fall if a hydraulic line or fitting is opened, or manual override button on hydraulic valve is pressed.

Always fully close hopper and lower screed to ground, or engage screed service locks when parking paver, or preparing paver for inspections, service and maintenance.

Proper troubleshooting begins with an organized approach to the problem. Begin with investigation of the most probable cause following the guidelines below.

Study the problem thoroughly before taking action:

- Did warning signs precede the problem?
- If so, what were they?
- What would they indicate?
- Is scheduled maintenance current on all parts and systems involved?
- Has similar trouble occurred before?
- What action was taken at that time?
- Are there any stored engine codes?
- Can engine be operated without further damage?

Check the most convenient items first.

Don't begin major work before checking all other possibilities.

Reconsider all known facts and clues before proceeding to more in-depth work. Correct the basic cause. Remember, failure of a certain part may be caused by malfunction of another part or system.

7.2 Engine Codes

Press button (1) to display any active engine codes. See OEM engine manual for explanation of error codes.

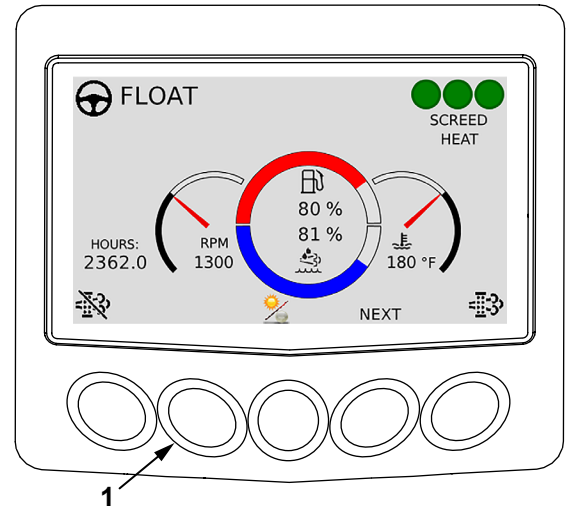

7.3 Troubleshooting Chart

Issue	Probable Cause	Corrective Action
No power or inadequate power.	Worn or malfunctioning pump or motor.	Repair or replace pump or motor.
	Stuck relief valve cartridge.	Repair or replace.
	Low system pressure caused by worn pump.	Repair or replace pump.
Surging of hydraulic items.	Air in system due to low level of oil, cavitating pump, leaky fittings, pinched hose, etc.	Investigate possible issues and correct as needed.
Screed overfeeds with material.	Head of material set too high.	Reset head of material to 12 inches and adjust as needed
	Sonic sensor is installed on incorrect side of paver.	Move sensors side to side.
	Asphalt is too close to sensor.	Remove asphalt away from sensor bottom, clean with dry rag if necessary. This can occur while retracting extensions.
Auto augers will not stop.	Sensor is out of range – asphalt is too close to sensor.	Turn switch from auto to off and back to auto. Auger will stop until asphalt level drops back into range.
Vibrator is on but not working.	Vibrator only runs during forward travel.	Come out of pause and begin forward motion.
Extensions are diving.	Improper screed slope setting.	Follow screed setting procedure. See section 5.3 Setting Screed To Pave.
	Material build-up inside extension.	Clean out material above extension heating chamber.
Loose or streaking mat	Screed plate is worn.	Change screed plate
	Crown setting is incorrect.	Adjust crown setting. See section 5 Screed Setup.

Issue	Probable Cause	Corrective Action
Engine stops.	Smart shut down activated.	See engine OEM manual.
	Manual shut down button activated.	Reset e-stop when it is safe to do so.
No steering control.	Pause light.	Toggle pause switch.
	Pause light is solid.	Position steer levers in neutral.
	Other operators station is selected	Match active station selector switch to your needs.
Screed automation will not power up.	Cables were connected with key switch on or paver running - 10 amp fuse blown.	Replace blown fuse in electrical panel.

8. Screed Automation Control System

8.1 Initial Setup

It is important to double check the system before you get to the paving jobsite. For best practice set up the system to insure you have all of the correct parts needed, and the controller is set to factory default settings. This will insure better success with the automated system.

8.2. Mounting the Sensors

8.2.1 Ground Mode (Single Grade Sensor and 4-Head Averaging Sensor)

1. Mount the Brackets to the outside of the screed end gate using the provided hardware. The arm can swing 180 degrees so the brackets may be used on either side of the paver.
2. Slide the vertical post to the horizontal arm, tighten the wing bolt to secure it.
3. Attach the grade sensor to the mounting bracket using the provided pin. Make sure the sensor has the "bail" wire attached.

For Joint matching set the sensor mount between the auger and the planetary. For height mount the sensor in the working window 14" - 19" above the matching surface.

Important

Don't forget to mount the reference bail and check that it is positioned correctly on the sensor. The working height must be between 14" and 19" from the bottom of the sensor to the matching surface.

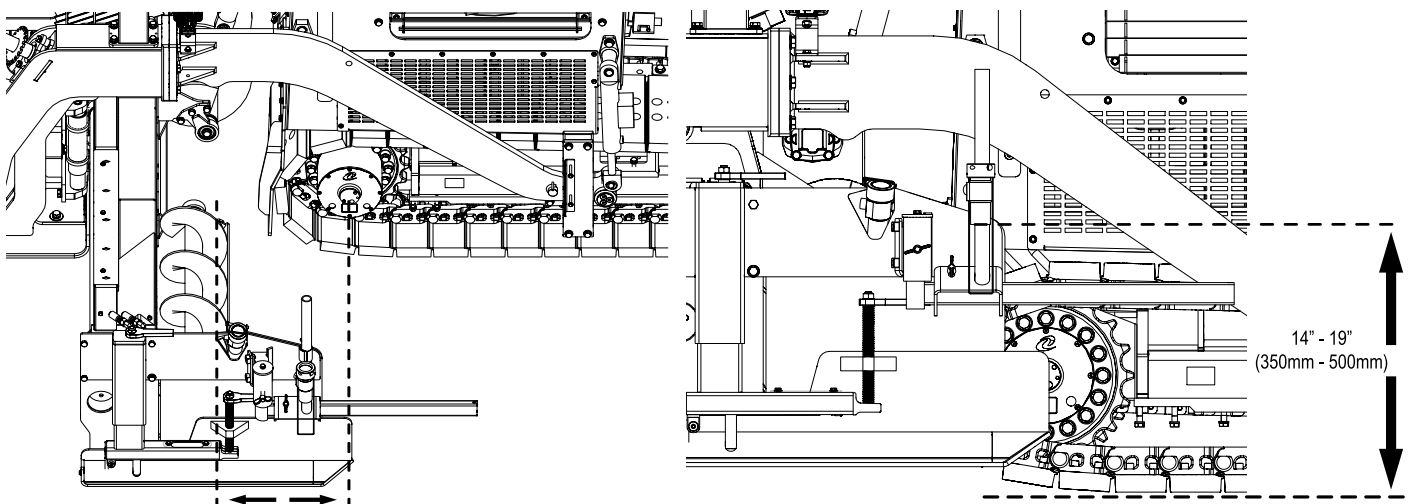

8.2.3 Stringline Mode (4-Head Averaging Sensor Only)

When the sensor is in stringline mode the large display must be lit.

When the sensor is in ground mode the small display must be lit.

Push the MODE button to switch between the two.

Working Window for Stringline Mode is .6in.

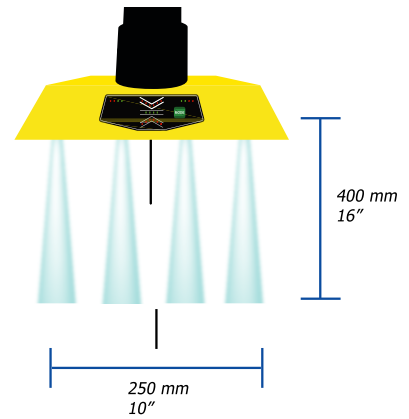

8.3 Hand Held Controller Setup

8.3.1 Manual Mode Functions

Setting	Shortcut	Display	Change	Confirm
Manual tow point adjustment			↓ ↑	
Set the reference (setpoint)			CAL	
Switch between sensors			MAN (2 sec.)	
Minimum Pulse	MAN + MODE >	PUL.	↓ ↑ >	MODE
Sensitivity	MODE >	S.E.n.	↓ ↑ >	MODE
Working Window	CAL + MODE >	□	↓ ↑ >	MODE
Dead Band	MAN + CAL >	.db.	↓ ↑ >	MODE
Switch to auto mode			AUTO	

8.3.2 Auto Mode Functions

Setting	Shortcut	Display	Change	Confirm
Adjust setpoint			↓ ↑	
Calibrate sensor value	CAL >	AUTO (flashes)	↓ ↑ >	CAL
Sensitivity	MODE >	S.E.n.	↓ ↑ >	MODE
Switch to manual mode			MAN	

8.3.3 Factory Default Settings

Minimum Pulse: 3 or 4

Working Window: 1" (Unless in stringline mode, use __. See 8.2.3)

Deadband: 0.04 (Joint Matching)

Road paving set deadband to .12

Sensitivity: 5-6

Sensitivity is dependant on Tow Point Cylinder Travel time. Adjust the travel speed to 10 seconds for full extension. If you do not wish to change travel speed use less sensitivity for faster travel speed.

8.3.4 Changing Hand Held Out Put

1860B uses a PNP output signal to activate the hydraulic valve coil. Grade systems are interchangeable with older Mauldin models. Some older models used NPN trigger system. Follow these instructions to change the output setting.

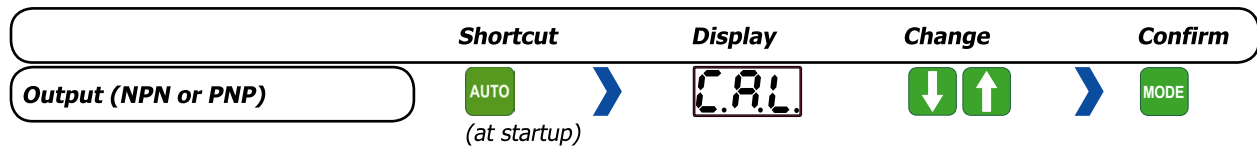

8.3.5 Changing from Metric to English Measurements:

To change from metric (mm) to English (inches) measurements follow these steps:

Press and hold the [CAL] key while the power is turned on.

After approx. 3 seconds the lower display will show “RES”

Release [CAL] key and press the UP [↑] arrow IMMEDIATELY (After a few seconds you can no longer make the changes and must start all over again).

“101” will now show in the top display

Use the UP [↑] ARROW quickly to change the value to “111”







Press [CAL] to store

8.4 Single Grade Setup

1. Lower the screed to the desired material thickness and make the machine ready for paving
2. Place the handset into the cradle at the operator’s station. Route cable over the resting bolt.
3. Plug into the paver receptacle labeled HAND HELD on the side of the operator station.
4. Plug one end of the cable into the grade sensor, and the other end into the paver receptacle labeled “Grade Sensor” on the operator stand. Make sure the sensors are in the working range of 14” to 19”.
5. Press AUTO to enter auto mode. The system will now maintain the level of the tow point constant relative to the setpoint
6. To increase mat thickness while paving in auto mode, press the arrows on the handset up or down. The change in mat thickness is displayed in the top display of the handset (only in auto mode)
7. When paving is completed, press MAN to return to manual mode, and the handset will stop controlling the tow point

8.5 Error Codes

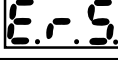



HS301 Hand Held

Symptom	Probable Cause	Appropriate Action
 Flashes on top display when entering AUTO mode	Setpoint not entered before pressing AUTO	<ul style="list-style-type: none"> Enter setpoint
	Sensor out of range	<ul style="list-style-type: none"> Adjust sensor position
	Reference bail damaged or not installed	<ul style="list-style-type: none"> Check or replace reference bail
	Sensor is faulty	<ul style="list-style-type: none"> Re-connect main power
	Using slope sensor on both sides	<ul style="list-style-type: none"> Adjust slope sensor to one side only
	Sensor is out of working window	<ul style="list-style-type: none"> Check working window
		<ul style="list-style-type: none"> Check sensor mounting
		<ul style="list-style-type: none"> Clean up sensor field of view
	No communication between HS301 and sensor	<ul style="list-style-type: none"> Check cables and connections

S298 Slope

Symptom	Probable Cause	Appropriate Action
Status LED - Slow flashes (2 short flashes per second)	No problems	
Status LED - Fast flashes (4 flashes per second, on/off equal amount of time)	HS301 missing	<ul style="list-style-type: none"> Check connection to HS301
	Sensor out of range	<ul style="list-style-type: none"> Adjust sensor position
	G220: Reference bail missing	<ul style="list-style-type: none"> Install reference bail

G221 and G224 Single Sonic Sensor & 4-Head Sonic Sensor

	(Red arrows flash alternately)	Target out of range	<ul style="list-style-type: none"> Adjust sensor position
	(Red arrows flash simultaneously)	Reference bail missing	<ul style="list-style-type: none"> Install reference bail
	(Green bar and red arrows flash)	No handset connected	<ul style="list-style-type: none"> Connect handset Check connections
	(Red arrows flash alternately)	The sensor has lost sight of the wire. Tow point is locked	<ul style="list-style-type: none"> Adjust paver direction Adjust sensor position

8.6 Daily Automation Setup

4. Lower the screed to the desired material thickness and make the machine ready for paving
5. Place the handset into the cradle at the operator's station. Route cable over the resting bolt.
6. Plug into the paver receptacle labeled HAND HELD on the side of the operator station.
7. Mount the Brackets to the outside of the screed end gate using the provided hardware. The arm can swing 180 degrees so the brackets may be used on either side of the paver.
8. Slide the vertical post to the horizontal arm, tighten the wing bolt to secure it.
9. Attach the grade sensor to the mounting bracket using the provided pin. Make sure the sensor has the "bail" wire attached.
10. Plug one end of the cable into the grade sensor, and the other end into the paver receptacle labeled "Grade Sensor" on the operator stand. Make sure the sensors are in the working range of 14" to 19".
11. Press AUTO to enter auto mode. The system will now maintain the level of the tow point constant relative to the setpoint
12. To increase mat thickness while paving in auto mode, press the arrows on the handset up or down. The change in mat thickness is displayed in the top display of the handset (only in auto mode)
13. When paving is completed, press MAN to return to manual mode, and the handset will stop controlling the tow point

9. Warranty



CALDER BROTHERS CORPORATION

(LIMITED) PRODUCT WARRANTY

Calder Brothers Corporation warrants that the Paver, Roller, Tank or Grader under this program will be free from defects in material and workmanship for a period of (12) twelve months from the date of installation. Written notice of any claimed defect must be given to Calder Brothers Corporation within the warranty period and within (30) thirty days after such defect is discovered. Liability under this warranty is limited to replacing or repairing at Calder Brothers Corporation election, any part or parts deemed defective after examination by Calder Brothers Corporation or an Authorized Service Representative via prepaid transportation for which is found to be defective, will be repaired or replaced and returned to the customer via prepaid surface transportation within the United States. Should any part be found not defective, inspection and handling may be charged to the customer by Mauldin or an Authorized Service Representative.

EXCLUSIONS:

This warranty does not apply to routine wearable parts of the Mauldin machine such as seals, points, plugs, hoses or similar items. This warranty does not extend to any machine or part replaced or repaired under this warranty. This warranty does not cover any repair or replacement labor or any part of parts found defective after examination by Mauldin or an Authorized Service Representative. This warranty does not apply to defects caused by casualty or unreasonable use, including faulty repairs by others and failure to provide reasonable and necessary maintenance.

THIS WARRANTY SET FORTH HEREIN IS IN LIEU OF AND EXCLUDES ANY AND ALL OTHER WARRANTIES, EXPRESSED OR IMPLIED, ARISING BY OPERATION OF LAW OR OTHERWISE, INCLUDING, BUT NOT LIMITED TO, ANY IMPLIED WARRANTY OF MERCHANTABILITY OR FITNESS FOR A PARTICULAR PURPOSE, AND CUSTOMER WAIVES ANY OBLIGATION OF LIABILITY OF MAULDIN ARISING IN TORT OR STRICT LIABILITY IN TORT, OR FOR LOSS OR USE, REVENUE OR PROFIT WITH RESPECT TO MAULDIN MACHINE AND/OR PARTS FOR ANY LIABILITY OF CUSTOMER TO ANY THIRD PARTY, OR FOR OTHER DIRECT, INCIDENTAL OR CONSEQUENTIAL DAMAGES.