

Instruction manual

Operating & Maintenance

Vibratory roller
3500_D

Engine
Kubota D722-E4B

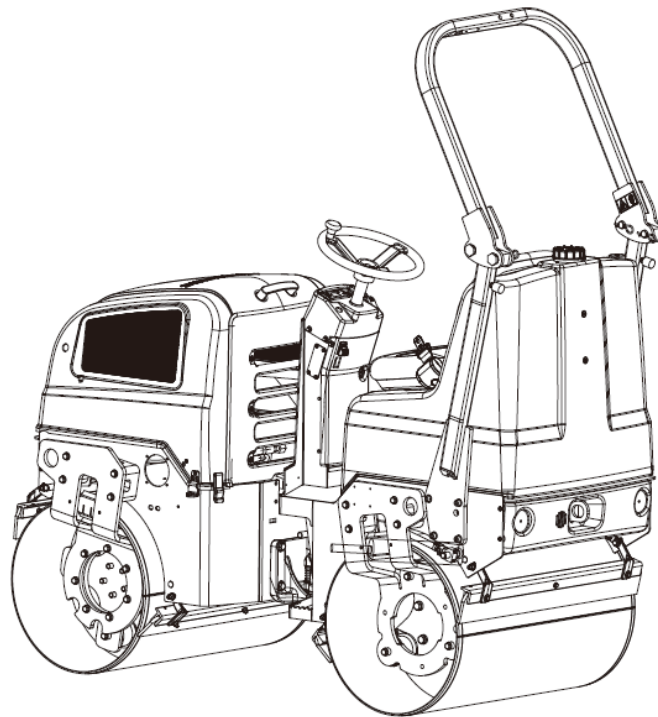

Translation of original instruction

*Reservation for changes
Printed in China*



Table of Contents

Introduction	1
The machine	1
Intended use	1
Warning symbols.....	1
Safety information	1
General	2
Safety - General instructions.....	3
Safety - when operating	5
Slopes	5
Driving near edges	6
Sitting position.....	7
Special instructions	9
Standard lubricants and other recommended oils and fluids	9
Higher ambient temperatures, above +40°C (104°F).....	9
Lower ambient temperature - Freeze risk	9
Temperatures.....	9
High pressure cleaning	9
Fire fighting	9
Roll Over Protective Structure (ROPS)	10
Battery handling	10
Jump starting.....	11
Technical specifications - Noise/Vibrations/Electrical	13
Vibrations - Operator station	13
Noise level.....	13
Technical specifications - Dimensions	15
Dimensions, side view.....	15
Dimensions, top view	16
Weights and volumes.....	17
Working capacity.....	17
General	17

Hydraulic system	18
Tightening torque	18
ROPS - bolts	19
Identification	19
Machine plate	19
Product identification number on the frame	20
Engine plates	21
Machine description- Decals	23
Location - decals	23
Safety decals.....	24
Info decals.....	25
Instruments/Controls	26
Locations - Instruments and controls	26
Function description	27
Electrical system.....	29
Relays and fuses on the machine	29
Operation	30
Before starting	30
Operator's seat - Adjusting.....	30
Sprinkler - Check	30
Reserve/parking brake	31
Operator position.....	31
Starting	32
Starting the engine	32
Driving	33
Operating the roller	33
Vibration	34
Manual vibration - Switching on	34
Operating - Stopping.....	36
Braking	36

Normal braking.....	36
Reserve brake.....	37
Switching off.....	37
Parking.....	38
Chocking the drums.....	38
Long-term parking.....	40
Engine.....	40
Battery.....	40
Air cleaner, exhaust pipe.....	40
Sprinkler system.....	40
Fuel tank.....	40
Hydraulic reservoir.....	40
Steering cylinder, hinges, etc.....	41
Hoods, tarpaulin.....	41
Miscellaneous.....	42
Locking the articulation.....	42
Lifting the roller.....	42
Unlocking the articulation.....	42
Securing CC950 for loading.....	43
Towing.....	44
Releasing the brake.....	44
Towing the roller.....	46
Operating instructions - Summary.....	48
Preventive maintenance.....	50
Acceptance and delivery inspection.....	50
Warranty.....	50
Maintenance - Lubricants and symbols.....	52
Maintenance symbols.....	54
Maintenance - Maintenance schedule.....	56
Service and maintenance points.....	56

General	57
Every 10 hours of operation (Daily).....	57
FIRST 50 hours of operation	58
Every 50 hours of operation	58
Every 200 / 600 / 1400 / 1800 hours of operation	58
Every 400 / 800 / 1200 / 1600 hours of operation	59
Every 1000 hours of operation	60
Every 2000 hours of operation	61
Maintenance - Maintenance measures, before use	62
Static drum - Filling with water	62
Maintenance, 10h	64
Water tank - Filling	64
Coolant level - Check	64
Air circulation - Check	64
Engine - Checking the oil level	65
Air cleaner - check	65
Sprinkler system - Check, cleaning.....	65
Scrapers - Check, adjustment.....	66
Hydraulic reservoir - Check/venting	66
Refueling	66
Warning lamps - Check.....	67
Brakes - Check	67
Maintenance - First 50h.....	68
Engine filter cartridge - Change	68
Hydraulic fluid filter - Change	69
Fuel filter - Change	69
Belt tension on the hydraulic pump drive belt - Check	69
Maintenance - 50h	70
Fuel filter - Clean	70
Fuel pipe - Check	70

Air cleaner - Clean	71
Rubber element and fastening screws - Check	71
Fan belt tension - Check	71
Water separator - Drain	72
Belt tension on the hydraulic pump drive belt - Check	72
Drum bearing seat - Check and lubrication	72
Maintenance - 200 / 600 / 1400 / 1800 h	73
Forward/Reverse controls and joints - Check and lubrication	73
Engine oil and filter cartridge - Change	74
Outside radiator core - Clean	74
Radiator hoses and clamp bands - Check	75
Intake air line - Check	75
Maintenance - 400 / 800 / 1200 / 1600 h	76
Fuel filter - Change	76
Water separator in fuel tank - Clean	76
Forward/Reverse controls and joints - Check and lubrication	77
Engine oil and filter cartridge - Change	77
Outside radiator core - Clean	78
Radiator hoses and clamp bands - Check	78
Air intake line - Check	79
Fan belt tension - Check	79
Air cleaner filter element - Change	79
Hydraulic reservoir - Check/venting	79
Steering joint - Check	79
Front drum - Checking the oil level	80
Belt tension on the hydraulic pump drive belt - Check	81
Maintenance - 1000 h	82
Forward/Reverse controls and joints - Check and lubrication	82
Outside / Inside radiator core - Clean	83
Fan belt - Change	83
Engine oil and filter cartridge - Change	84

Engine valve clearance - Check	84
Coolant freezing point - Check	85
Air cleaner filter element - Change	85
Hydraulic reservoir - Check/venting.....	85
Hydraulic fluid filter - Change	86
Steering joint - Check	86
Front drum - Changing the oil	86
Front drum - Checking the oil level	87
Valve gasket - Change.....	87
Belt tension on the hydraulic pump drive belt - Check	87
Maintenance - 2000 h	88
Water tank - Cleaning	88
Outside / Inside radiator core - Clean	88
Fan belt - Change	89
Fuel filter - Change	89
Engine oil and filter cartridge - Change	90
Engine breather valve - Change	90
Fuel tank - Cleaning	91
Engine valve clearance - Check	91
Coolant freening point - Check	91
Air cleaner filter element - Change	92
Hydraulic fluid filter - Change	92
Hydraulic reservoir - Check/venting.....	92
Hydraulic reservoir - Fluid change	93
Steering joint - Check	94
Front drum - Changing the oil	94
Forward/Reverse controls and joints - Check and lubrication.....	95
Belt tension on the hydraulic pump drive belt - Check	96
Disposal	97

Introduction

The machine

Mauldin 3500_D is a self-propelled vibratory tandem roller in the 1,5 metric tonnes class featuring 900 mm wide drums. The machine is equipped with drive, brakes, and vibration on both drums.

Intended use

3500_D is primarily used for smaller compaction works, such as minor roads, sidewalks, cycle ways and minor parking places.

The attachment or installation of additional devices, which are used to intervene in the function of the machine or with which its function are supplemented, is only permitted with the written approval of the manufacturer.

If necessary, approval should be sought from local authorities.

Consent from the authorities is however no substitute for approval from the manufacturer.

Warning symbols



WARNING ! Marks a danger or a hazardous procedure that can result in life threatening or serious injury if the warning is ignored.



CAUTION ! Marks a danger or hazardous procedure that can result in damage to the machine or property if the warning is ignored.

Safety information



The safety manual supplied with the machine must be read by all roller operators. Always follow the safety instructions. Do not remove the manual from the machine.



Read the entire manual before starting the machine and before carrying out any maintenance.



Ensure good ventilation (extraction of air by fan) where the engine is run indoors.



Replace immediately the instruction manuals if lost, damaged or unreadable.



Prevent persons from entering or remaining in the danger area, i.e. a distance of at least 7 m (23 ft) in all directions from operating machines. The operator may allow a person to remain in the danger area, but should then observe caution and operate the machine only when the person is visible or has given clear indications of where he or she is.

CALIFORNIA

Proposition 65 Warning

Gasolin engine exhaust and some of its constituents are known to the State of California to cause cancer, birth defects, and other reproductive harm.

General

This manual contains instructions for machine operation and maintenance.

The machine must be correctly maintained for maximal performance.

The machine should be kept clean so that any leakages, loose bolts and loose connections are discovered at as early a point in time as possible.

Inspect the machine every day, before starting. Inspect the entire machine so that any leakages or other faults are detected.

Check the ground under the machine. Leakages are more easily detected on the ground than on the machine itself.



THINK ENVIRONMENT ! Do not release oil, fuel and other environmentally hazardous substances into the environment. Always send used filters, drain oil and fuel remnants to environmentally correct disposal.

This manual contains instructions for periodic maintenance normally carried out by the operator.



Additional instructions for the engine can be found in the manufacture's engine manual.

Safety - General instructions

(Also read the safety manual)



1. The operator must be familiar with the contents of the OPERATION section before starting the roller.
2. Ensure that all instructions in the MAINTENANCE section are followed.
3. Only trained and/or experienced operators are to operate the roller. Passengers are not permitted on the roller. Remain seated at all times when operating the roller.
4. Never use the roller if it is in need of adjustment or repair.
5. Only mount and dismount the roller when it is stationary. Use the intended grips and rails. Always use the three-point grip (both feet and one hand, or one foot and both hands) when mounting or dismounting the machine. Never jump down from the machine.
6. The ROPS (Roll Over Protective Structure) should always be used when the machine is operated on unsafe ground.
7. Drive slowly in sharp bends.
8. Avoid driving across slopes. Drive straight up or straight down the slope.
9. When driving close to edges, ditches or holes, make sure that at least 2/3 of the drum width is on previously compacted material (solid surface).
10. Make sure that there are no obstacles in the direction of travel, on the ground, in front of or behind the roller, or overhead.
11. Drive particularly carefully on uneven ground.
12. Use the safety equipment provided. The seat belt must be worn on machines fitted with ROPS/ROPS-cab.
13. Keep the roller clean. Clean any dirt or grease that accumulates on the operator platform immediately. Keep all signs and decals clean and legible.
14. Safety measures before refueling:
 - Stop the engine
 - Do not smoke.
 - No naked flames in the vicinity of the roller.
 - Earth the filling equipment nozzle to the tank opening to avoid sparks.
15. Before repairs or service:
 - Chock the drums/wheels and under the strike-off blade.
 - Lock the articulation if necessary

Safety - General instructions

16. Hearing protection is recommended if the noise level exceeds 85 dB(A). The noise level can vary depending on the equipment on the machine and the surface the machine is being used on.
17. Do not make any changes or modifications to the roller that could affect safety. Changes are only to be made after written approval has been given by Mauldin.
18. Avoid using the roller before the hydraulic fluid has reached its normal working temperature. Braking distances can be longer than normal when the fluid is cold. See instructions in the STOP section.
19. For your own protection always wear:
 - helmet
 - working boots with steel toecaps
 - ear protectors
 - reflecting clothing/high visibility jacket
 - working gloves

Safety - when operating



Prevent persons from entering or remaining in the danger area, i.e. a distance of at least 7 m (23 ft) in all directions from operating machines. The operator may allow a person to remain in the danger area, but should then observe caution and operate the machine only when the person is visible or has given clear indications of where he or she is.

Slopes

This angle has been measured on a hard, flat surface with the machine stationary.

The steering angle was zero, the vibration was switched off and all tanks were full.

Always take into consideration that loose ground, steering the machine, vibration on, machine speed across the ground and raising the center of gravity can all cause the machine to topple at smaller slope angles than those specified here.

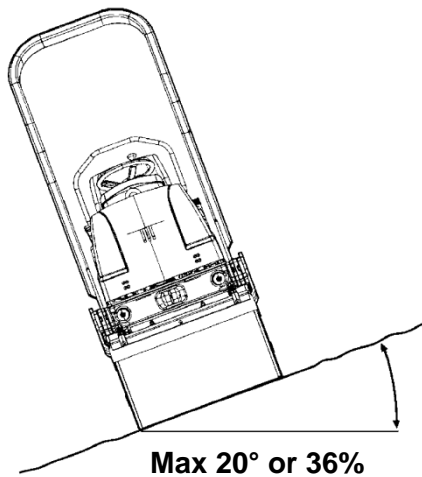

Fig. Operating on slopes



It is recommended that the ROPS (Roll Over Protective Structure) is always used when driving on slopes or unsafe ground.



Where possible, avoid driving across slopes. Drive instead straight up and down sloping ground.

Driving near edges

When driving near an edge, minimum 2/3 of the drum width must be on solid ground.



Keep in mind that the machine's center of gravity moves outwards when steering. For example, the center of gravity moves to the right when you steer to the left.

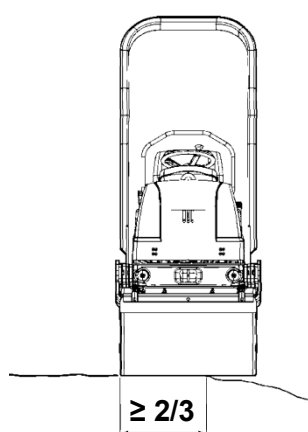

Fig. Position of drum when driving near an edge

Sitting position

Remain seated at all times when operating the roller.

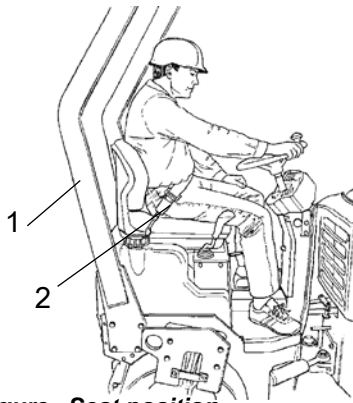

Figure. Seat position

1. ROPS
2. Seat belt



Always use the seat belt where fitted. Where the seat belt is not used, there is a great risk that the operator will be thrown off and land under the machine if the machine topples over.

The seat belt is standard equipment on rollers fitted with Roll Over Protective Structure (ROPS) (1).



ROPS should always be in the raised position when machines with foldable ROPS are operated

Special instructions

Standard lubricants and other recommended oils and fluids

Before leaving the factory, the systems and components are filled with the oils and fluids specified in the lubricant specification. These are suitable for ambient temperatures in the range -15°C to +40°C (5°F - 105°F).

Higher ambient temperatures, above +40°C (104°F)

For operation of the machine at higher ambient temperatures, although maximum +50°C (122°F), the following recommendations apply:

The diesel engine can be run at this temperature using normal oil. However, the following fluids must be used for other components:

Hydraulic system - mineral oil Shell Tellus T100 or equivalent.

Lower ambient temperature - Freeze risk

Make sure that the watering system is empty/drained of water (sprinkler, hoses, tank/s) or that anti-freeze has been added, to prevent the system freezing.

Temperatures

The temperature limits apply to standard versions of rollers.

High pressure cleaning

Do not spray water directly onto electrical components or the instrument panels.

Place a plastic bag over the fuel filler cap and secure with a rubber band. This is to avoid high pressure water entering the vent hole in the filler cap. This could cause malfunctions, such as the blocking of filters.



Never aim the water jet directly at the fuel tank cap. This is particularly important when using a high-pressure cleaner.

Fire fighting

If the machine catches fire, use an ABC-class powder fire extinguisher.

A BE-class carbon dioxide fire extinguisher can also be used.

Roll Over Protective Structure (ROPS)



Never carry out any welding or drilling operations of any kind on the Roll Over Protective Structure (ROPS).



Never attempt to repair a damaged ROPS structure. This must be replaced with new ROPS structure.

Battery handling



When removing batteries, always disconnect the negative cable first.



When fitting batteries, always connect the positive cable first.



Dispose of old batteries in an environmentally friendly way. Batteries contain toxic lead.



Do not use a quick-charger for charging the battery. This may shorten battery life.

Jump starting



Do not connect the negative cable to the negative terminal on the dead battery. A spark can ignite the oxy-hydrogen gas formed around the battery.



Check that the battery used for jump starting has the same voltage as the dead battery.

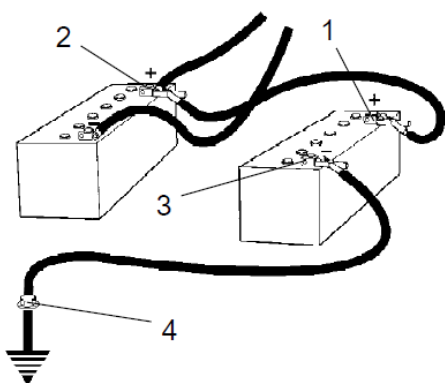

Fig. Jump starting

Turn the ignition and all power consuming equipment off. Switch off the engine on the machine which is providing jump start power.

First connect the jump start battery's positive terminal (1) to the flat battery's positive terminal (2). Then connect the jump start battery's negative terminal (3) to, for example, a bolt (4) or the lifting eye on the machine with the flat battery.

Start the engine on the power providing machine. Let it run for a while. Now try to start the other machine. Disconnect the cables in the reverse order.

Technical specifications - Noise/Vibrations/Electrical

Technical specifications - Noise/Vibrations/Electrical

Vibrations - Operator station (ISO 2631)

The vibration levels are measured in accordance with the operational cycle described in EU directive 2000/14/EC on machines equipped for the EU market, with vibration switched on, on soft polymer material and with the operator's seat in the transport position.

Measured whole-body vibrations are below the action value of 0.5 m/s^2 as specified in Directive 2002/44/EC. (Limit is 1.15 m/s^2)

Measured hand/arm vibrations also were below the action level of 2.5 m/s^2 specified in the same directive. (Limit is 5 m/s^2)

Noise level

The noise level is measured in accordance with the operational cycle described in EU directive 2000/14/EC on machines equipped for the EU market, on soft polymer material with vibration switched on and the operator's seat in the transport position.

Guaranteed sound power level, L_{wA} 102 dB (A)

Sound pressure level at the operator's ear (platform), L_{pA} 84 \pm 3 dB (A)

During operation the above values may differ because of the actual operational conditions.

Technical specifications - Dimensions

Dimensions, side view

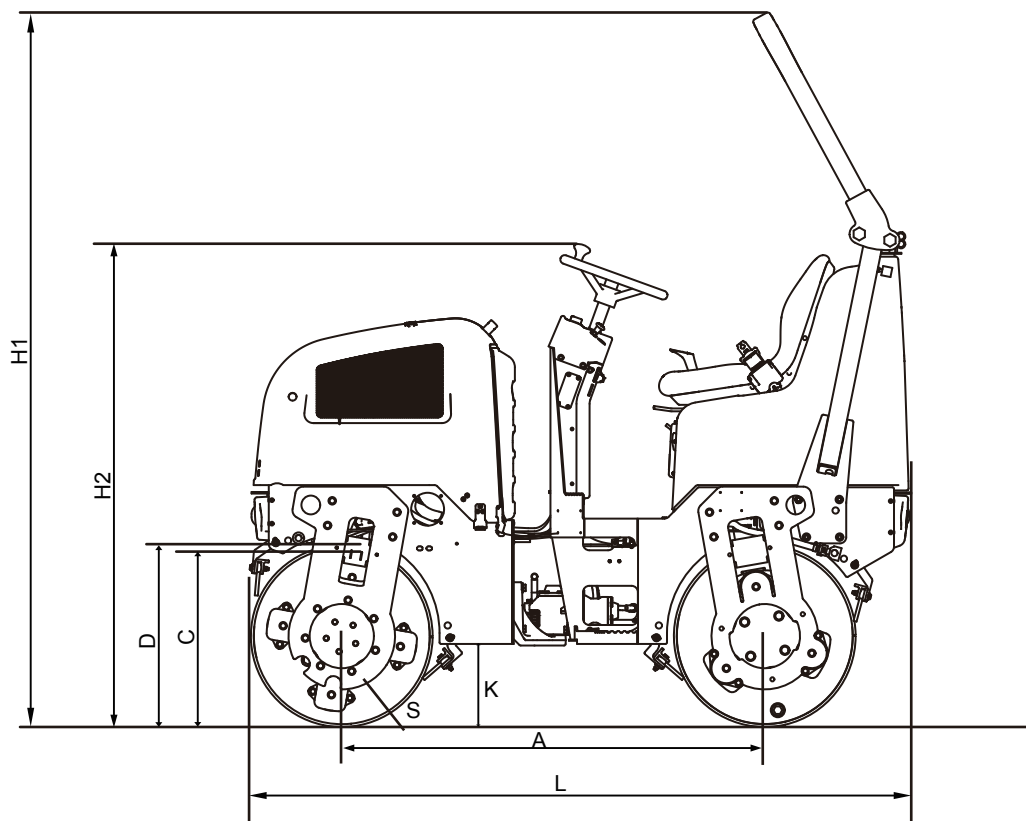

	Dimensions	mm	in
A	Wheelbase	1350	53,1
D	Drum diameter	584	23,0
H ₁	Height, with ROPS	2300	90,5
H ₂	Height, w/o ROPS	1585	62,4
K ₁		455	17,9
K ₂	Ground clearance	261	10,3
L ₂	Length	2107	83,0
S	Drum shell thickness	13	0,51

Technical specifications - Dimensions

Dimensions, top view

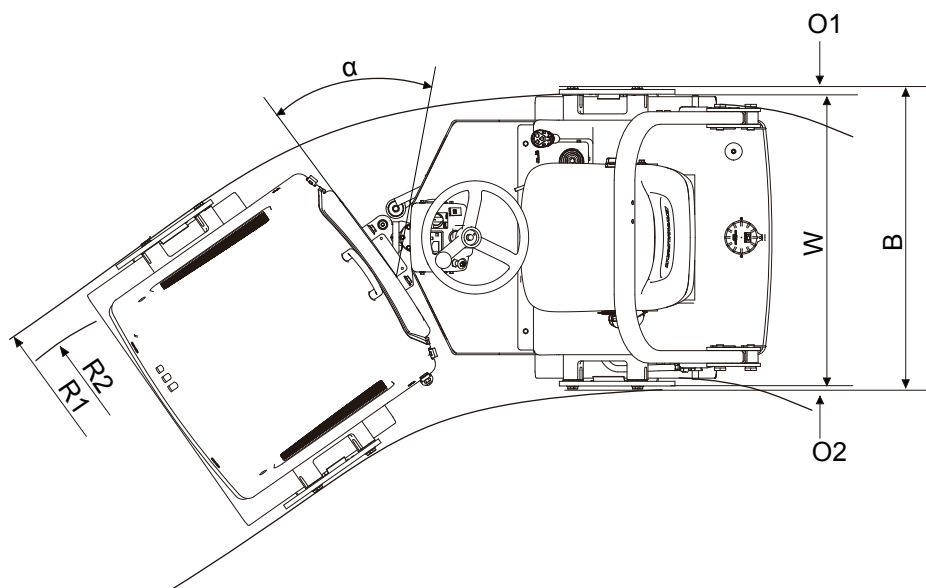

	Dimensions	mm	in
B	Width	970	38,2
O	Overhang	35	1,38
R_1	Turning radius, outside	2700	106,3
R_2	Turning radius, outer, drum edge	2660	104,7
W	Drum shell thickness	900	35,4
α	Steering angle	$\pm 34^\circ$	$\pm 34^\circ$

Technical specifications - Dimensions

Weights and volumes

Weights

Operating mass (EN500)	1425 kg	3140 lbs
------------------------	---------	----------

Fluid volumes

Fuel tank	23 liters	6,0 gal
Water tank	175 liters/tank	46,2 gal

Working capacity

Compaction data

Static linear load, front	6,9 kg/cm	38,66 pli
Static linear load, rear	8,9 kg/cm	49,86 pli
Amplitude	0,4 mm	0,016 in
Vibration frequency	70 Hz	4200 rpm
Centrifugal force	16,7 kN	3752 lb

Note: The frequency is measured at high revs. The amplitude is measured as the real value and not the nominal.

Propulsion

Speed range	0-8	kph	0-5	mph
Climbing capacity (theoretical)	35	%		

General

Engine

Manufacturer/Model	Kubota D722-E4B
(KW/3,600 rpm) Max. power (KW/3600rpm)	14,9

Electrical system

Battery	12V 60Ah
Charging coil	12V 20A
Fuses	See the Electrical system section - fuses

Technical specifications - Dimensions

Hydraulic system

Opening pressure	MPa	Psi
Drive system	27,0	3915
Supply system	2,0	290
Vibration system	22,0	3190
Control systems	7,0	1015
Brake disengagement	2,0	290

Tightening torque

Tightening torque in Nm for oiled, bright galvanized bolts tightened using a torque wrench.

STRENGTH CLASS

M - thread	8.8	10.9	12.9
M6	8,4	12	14,6
M8	21	28	34
M10	40	56	68
M12	70	98	117
M16	169	240	290
M20	330	470	560
M24	570	800	960
M30	1130	1580	1900
M36	1960	2800	-

Technical specifications - Dimensions

ROPS - bolts

Bolt dimensions :	M12 (PN 508063)
Strength class :	8.8
Tightening torque :	70 Nm



ROPS-bolts which are to be torque tightened must be dry.

Identification

Machine plate

The machine plate (1) is attached to the front left side of the rear frame, beside the steering joint.

The plate specifies the manufacturers name and address, the type of machine, the PIN, Product Identification Number (serial number), operating weight, engine power and year of manufacture. CE markings and the year of manufacture may be omitted on machines supplied to markets outside the EU.

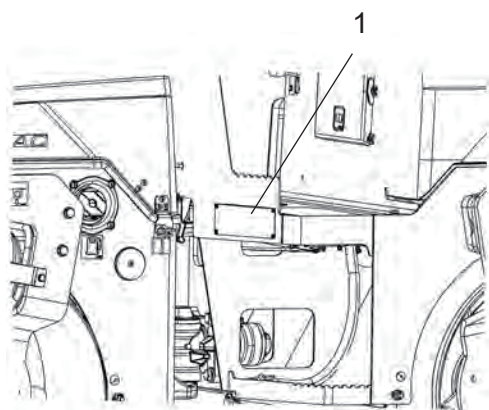



Fig. Operator's platform, left side
1. Machine plate

 Calder Brothers Corporation 450 E Warehouse Ct, Taylors, SC 29687			
Product Identification Number			
Designation	Type	Rated Power	Max axle load front / rear
ROLLER	3500_D	14.9 kW	600/800 kg
Gross machinery mass	Operating mass	Max ballast	
1350 kg	1295 kg	— kg	
Made in China <small>4812 120cxx</small>			

Please state the machine's PIN when ordering spares.

Technical specifications - Dimensions

Product identification number on the frame

The machine PIN (Product Identification Number) (1) is punched on the right edge of the front frame.

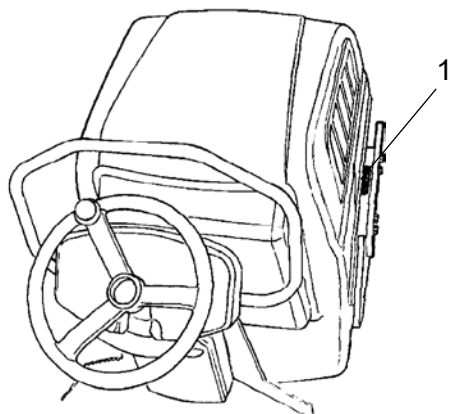
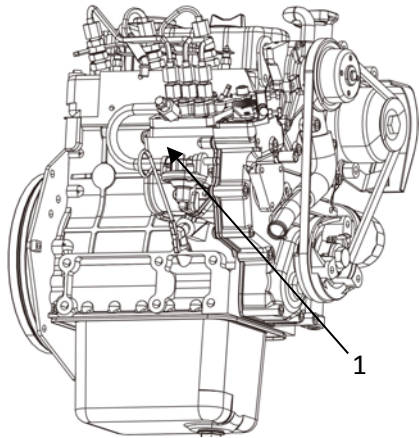

Fig. PIN Front frame



Engine plates

The engine serial number (1) is punched on the side of the engine.

Please specify the engine serial number when ordering spares. Refer also to the engine manual.

Figure. Engine
1. Serial number

Machine description- Decals

Location - decals

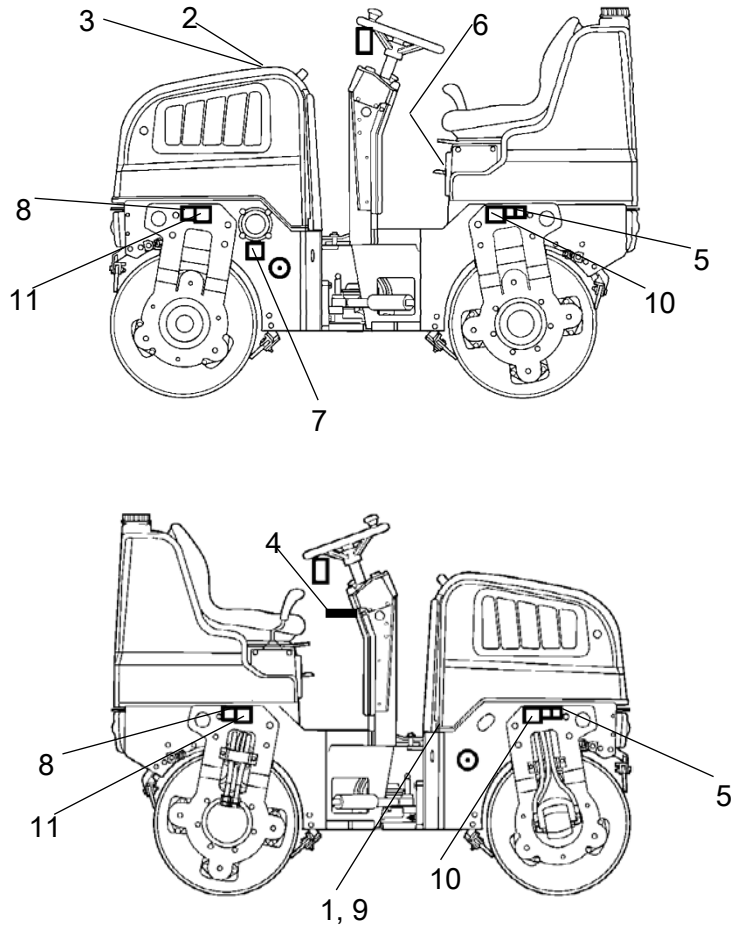
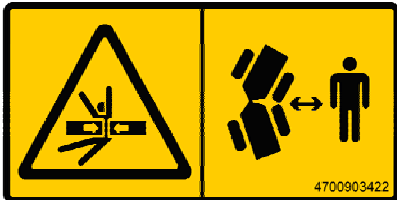

Fig. Location, decals and signs

1.	Warning, Crush zone	4700903422	8.	Lifting point	4700357587
2.	Warning, Rotating engine components	4700903423	9.	Hydraulic fluid level	4700272373
3.	Warning, Hot surfaces	4700903424	10.	Hoisting plate	4700904870
4.	Warning, Instruction manual	4700903459	11.	Fixing point	4700382751
5.	Warning, Locking	4700908229			
6.	Handbook compartment	4700903425			
7.	Diesel fuel	4700991658			

Safety decals

Always make sure that all safety decals are completely legible, and remove dirt or order new decals if they have become illegible. Use the part number specified on each decal.



4700903422

Warning - Crush zone, articulation/drum.

Maintain a safe distance from the crush zone.

(Two crush zones on machines fitted with pivotal steering)

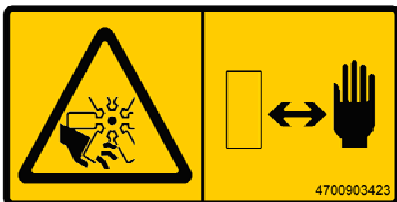

4700903423

Warning - Rotating engine components.

Keep your hands at a safe distance.

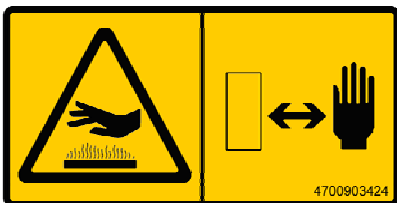

4700903424

Warning - Hot surfaces in the engine compartment.

Keep your hands at a safe distance.

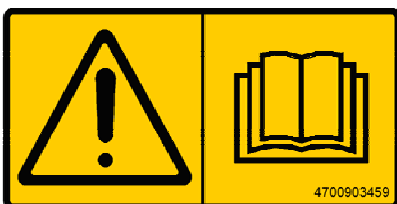

4700903459

Warning - Instruction manual

The operator must read the safety, operation and maintenance instructions before operating the machine.



4700908229

Warning - Risk of crushing

The articulation must be locked when lifting.

Read the instruction manual.

Info decals

Handbook compartment



Diesel



Lifting point



Hydraulic oil level



Hoisting plate

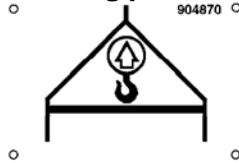

Securing point

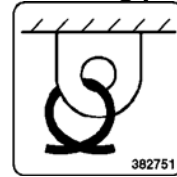

Instruments/Controls

Locations - Instruments and controls



- 1. Ignition key
- 2. Control, engine speed
- 3. Parking brake
- 4. Vibration on/off, switch
- 5. Control panel
- 6. Forward/reverse lever
- 7. Fuse box
- 8. Sprinkler
- 9. Horn
- 10. Not in use
- 20. Emergency stop



Fig. Instruments

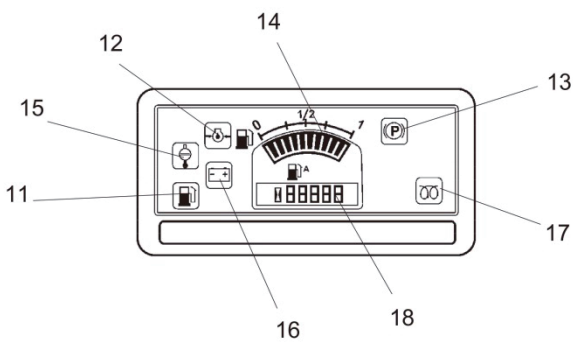

- 11. Low fuel level
- 12. Oil pressure, engine
- 13. Parking brake lamp
- 14. Fuel level
- 15. Water temperature, engine
- 16. Battery/charging
- 17. Glow plug
- 18. Hour meter

Fig item 5. Control panel

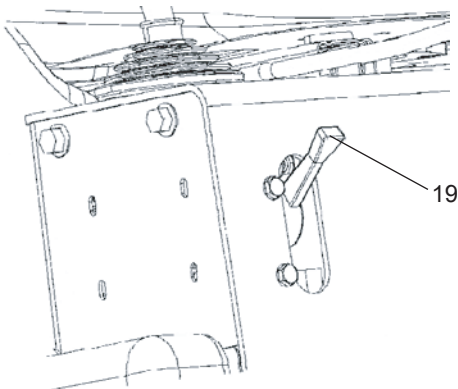

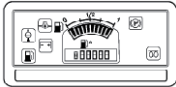







Fig. Speed control, improved design
19. Speed control

Function description

No	Designation	Symbol	Function
1.	Starter switch		The electric circuit is broken. All instruments and electrical controls are supplied with power. Starter motor activation.
2.	Control, engine speed, previous design with plastic knob		Pull the lever up to obtain working speed. Move the lever down to obtain idling speed.
3.	Parking brake		The parking brake is activated if pressed when the machine is stationary. The brakes are released when pulled out.
4.	Vibration On/Off. Switch		When the switch for vibrations in the forward/reverse lever is pressed and released, the vibrations are engaged. Press the switch again to disengage the vibrations.
5.	Control panel		
6.	Forward/Reverse lever		The lever must be in neutral to start the engine. The engine cannot be started if the forward/reverse lever is in any other position. The forward/reverse lever controls both the roller's driving direction and speed. When the lever is moved forward, the roller moves forward etc. The roller's speed is proportional to the distance the lever is from the neutral position. The further the lever is from the neutral position, the higher the speed.
7.	Fuse box (on control column)		Contains fuses for the electrical system. See under the heading 'Electrical system' for a description of fuse functions.
8.	Sprinkler, control		Turn the knob clockwise to switch on the water flow to the drum.
9.	Horn, switch		Press to sound the horn.
10.	Not in use		
11.	Warning lamp, low fuel level		The lamp comes on when the fuel level in tank is low.
12.	Warning lamp, oil pressure		This lamp lights if the lubricating pressure in the engine is too low. Stop the engine immediately and locate the fault.
13.	Warning lamp, parking brake		The lamp lights when parking brake is activated.
14.	Fuel level		Shows the fuel level in the diesel tank.
15.	Warning lamp, water temperature		The light comes on if the water temperature is too high.
16.	Warning lamp, battery charging		If the lamp lights while the engine is running the alternator is not charging. Stop the engine and locate the fault.

Machine description- Decals

Function description

No	Designation	Symbol	Function
17.	Warning lamp, glow plug		The lamp must go out before the starter switch is moved to position 3c for activation for the starter motor.
18.	Hour meter		Shows the number of hours the engine has run.
19.	Control, engine speed, improved design		Pull the lever up to obtain idling speed. Move the lever down to obtain working speed.
20.	Emergency stop		Brakes the roller and switches off the engine. The power supply goes off. NOTE: The emergency stop must be deactivated when starting the machine.

Electrical system

Relays and fuses on the machine

The figure shows the positions of the various fuses and relays. The table below gives their amperage and function. All fuses are flat pin fuses.

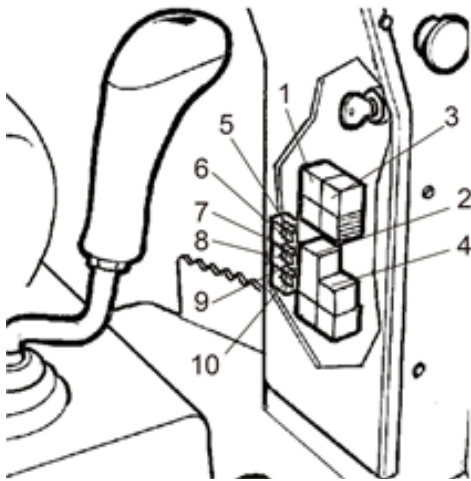

Fig. Control column

Relays

1	K1	Starting	12V 30A
2	K2	Start, vibration, brake	12V 15A
3	K3	Brake lamp	12V 30A
4	K4	Drive restriction relay	12V 10A

Fuses

5	FU1.1	Ignition switch, Main fuse	20A
6	FU1.2	Instruction panel, VBS relay, Restriction relay, Vibration, Brake	7.5A
7	FU1.3	Horn, Back-up alarm	10A
8	FU1.4	Cooling fan, Hydraulic oil, Rotating beacon, Working lights	20A
9	FU1.5	Engine intake air preheat	5A
10	FU1.6	Engine intake air preheat	10A

Operation

Before starting

Operator's seat - Adjusting

Adjust the operator's seat so that the position is comfortable and so that the controls are within easy reach.

The seat can be adjusted lengthways (1).



Fig. Operator's seat
1. Length adjustment

Sprinkler - Check



Make sure that the reserve/parking brake knob is actually pressed in.



Figure. Instrument panel
1. Ignition key
3. Parking brake
8. Switch, sprinkler

Set the knob (8) for the sprinkler in the open position and check that the drums are watered.

Parking brake



Activate parking brake before leaving the machine.



The machine starts with the parking brake deactivated.

Emergency stop

The machine starts with emergency stop pulled out.

Figure. Control panel
3. Parking brake
20. Emergency stop

Operator position



Replace the seat belt (1) if it shows signs of wear or has been subjected to high levels of force.



Never use the forward/reverse levers as a handle when mounting or disembarking from the roller.



Ensure that the anti-slip (3) on the platform is in good condition. Replace where anti-slip friction is poor.

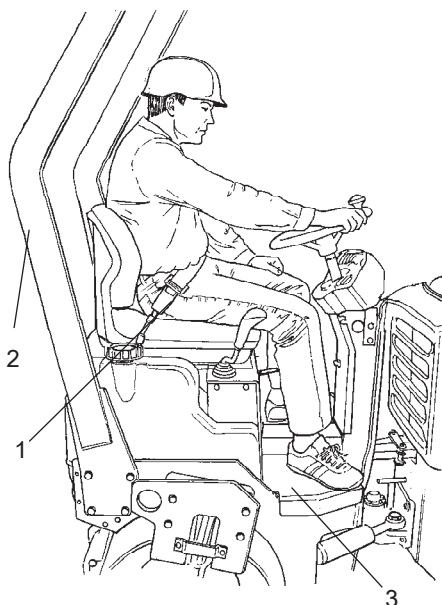

Fig. Operator's station
1. Seat belt
2. ROPS (Option)
3. Anti-slip

If a ROPS (Roll Over Protective Structure) (2) is fitted to the roller, always wear the seat belt (1) provided and wear a protective helmet.

Starting

Starting the engine

Make sure that the parking brake (3) is activated.

Sit down in the operator's seat and set the forward/reverse lever (6) in neutral. You cannot start the diesel engine with the lever in any other position.

Set the RPM control (2) to idle.

For cold start: Insert the key to Ignition (1) Pos.0, turn the key to the right, the key goes through Pos. I get power supply then Pos. II to Pre-heat the roller, the lights on control panel would light up , then arrive to the start position III. As soon as the engine has started, release the ignition key.



Do not run the starter motor for too long. If the engine does not start immediately, wait a minute or so before trying again.



Figure. Control panel

- 1. Ignition key
- 2. Speed control
- 3. Parking brake
- 6. Forward/Reverse lever

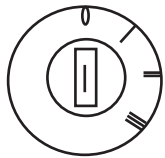

Figure 1. Ignition key
 Pos.0: Key Insert / Shut down
 Pos.I: Power supply
 Pos.II: Pre-heat
 Pos.III: Start

Warm up the engine at idling speed for a few minutes, although longer if ambient temperature is below +10 C° (50 F°)

When the engine is warm, check that the emergency stop warning lamp (5) is still lit.



When starting and driving a machine that is cold, remember that the hydraulic fluid is also cold and that braking distances can be longer than normal until the machine reaches the working temperature.



Ensure that there is good ventilation (air extraction) if the engine is run indoors. Risk of carbon monoxide poisoning.



Fig. Instrument panel

- 5. Warning lamp Emergency stop

Carefully move the forward/reverse lever (6) forwards or backwards, depending on which direction of travel is required.

Speed increases as the lever is moved away from the neutral position.



The speed should always be controlled using the forward/reverse lever and never by changing the engine speed.



Test the function of the reserve brake by pressing the reserve/parking brake knob (3) while the roller is moving slowly forwards and backwards.

Check when operating that the warning lamps do not come on.

A hydraulic fluid cooler is recommended for warm ambient temperatures and long operating periods

Driving

Operating the roller



Under no circumstances is the machine to be operated from the ground. The operator must be seated inside the machine during all operation.

Deactivate the parking brake (3). Be prepared that the roller can move.

Check that the steering is working correctly by turning the steering wheel once to the right and once to the left while the roller is stationary.

When compacting asphalt, remember to turn on the sprinkler system (8).



Make sure that the area in front of and behind the roller is clear.



Figure. Instrument panel
1. Starter switch
2. Speed control
3. Parking brake
6. Forward/Reverse lever
8. Sprinkler knob
20. Emergency stop





Fig. Forward/Reverse lever
4. Switch, vibration On/Off

Vibration

Manual vibration - Switching on



Vibration should not be active when the roller is stationary. This can damage both the surface and the machine.

Engage and disengage vibration using the switch (4) on the underside of the forward/reverse lever.

Always switch off vibration before the roller comes to a standstill.

Operating - Stopping

Braking

Normal braking



When starting and driving a machine that is cold, remember that the hydraulic fluid is also cold and that braking distances can be longer than normal until the machine reaches the working temperature.

Press the switch (4) to switch off the vibration.

Move the forward/reverse lever (6) to the neutral position to stop the roller.

For shorter stopping periods, in which the operator needs to stand up with the engine running, it is important to check that the brake light is lit, including when stopping briefly on sloping ground.

Turn the engine speed control (2) back to idling and stop the engine. Switch off the machine using the key (1). Activate the parking brake (3).



Fig. Control panel

- 1. Key**
- 2. Engine speed control**
- 3. Parking brake**
- 4. Vibration On/Off**
- 6. Forward/reverse lever**



Fig. Controls
3. Parking brake
20. Emergency stop

Reserve brake

Braking is normally activated using the forward/reverse lever. The hydrostatic transmission retards and slows the roller when the lever is moved towards the neutral position.

A disc brake in each drum motor acts as reserve brake when in motion and as a parking brake when stationary.



To brake in an emergency situation, press in the emergency stop (10), hold the steering wheel firmly and be prepared for a sudden stop.

After braking, return the forward/reverse lever to the neutral position and pull out the emergency stop knob.



Activate the parking brake (3) before leaving the machine.



Fig. Instrument panel
1. Starter switch

Switching off

Turn the ignition key (1) to the left to shut off position.

Parking

Chocking the drums



Never disembark from the machine when the engine is running, unless the reserve/parking brake knob is depressed.



Make sure that the roller is parked in a safe place with respect to other road users. Chock the drums if the roller is parked on sloping ground.



Keep in mind that there is a risk of freezing during the winter. Drain the water tanks and water lines.

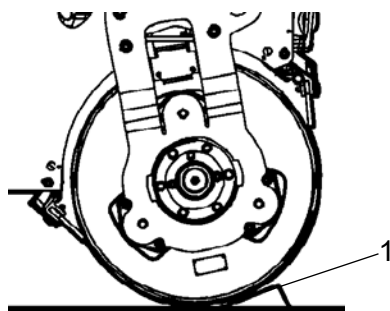

Fig. Set-up
1. Chocks

Long-term parking

 The following instructions should be followed when long term parking (more than one month).

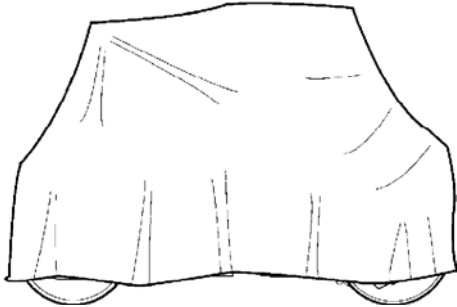

Fig. Roller weather protection

These measures apply when parking for a period of up to 6 months.

Before re-commissioning the roller, the points marked with an asterisk * must be returned to the pre-storage state.

Wash the machine and touch up the paint finish to avoid rusting.

Treat exposed parts with anti-rust agent, lubricate the machine thoroughly and apply grease to unpainted surfaces.

Engine

* Refer to the manufacturer's instructions in the engine manual that is supplied with the roller.

Battery

* Remove the battery from the machine, clean, grease the cable connectors (terminals) and trickle charge the battery once a month. The battery is otherwise maintenance free.

Air cleaner, exhaust pipe

* Cover the air cleaner (see under the heading 'Every 50 hours of operation' or 'Every 300 hours of operation') or its opening with plastic or tape. Also cover the exhaust pipe opening. This is to avoid moisture entering the engine.

Sprinkler system

* Empty the water tank and all hoses of all water (see under the heading "Every 2000 hours of operation").

Fuel tank

Fill the fuel tank completely full to prevent condensation.

Hydraulic reservoir

Fill the hydraulic reservoir to the uppermost level mark (see under the heading 'Every 10 hours of operation.')

Steering cylinder, hinges, etc.

Grease the steering cylinder piston with conservation grease.

Grease the hinges on the doors to the engine compartment. Grease both ends of the forward/reverse control (bright parts) (see under the heading 'Every 500 hours of operation').

Hoods, tarpaulin

* Lower the instrument cover over the instrument panel.

* Cover the entire roller with a tarpaulin. A gap must be left between the tarpaulin and the ground.

* If possible, store the roller indoors and ideally in a building where the temperature is constant.

Miscellaneous

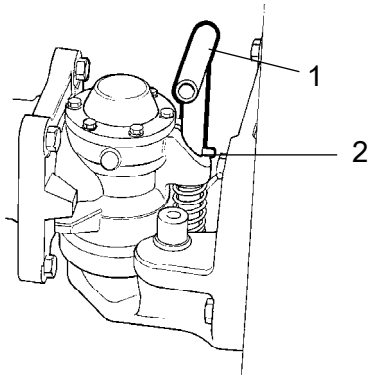

Fig. Steering joint
 1. Locking arm
 2. Cotter pin in locked position

Locking the articulation

Turn the steering wheel to the straight ahead position.

Raise the locking arm (1) and turn 180 degrees downward. Ensure that the cotter pin (2) is guided into its lower position correctly for locking the articulation.

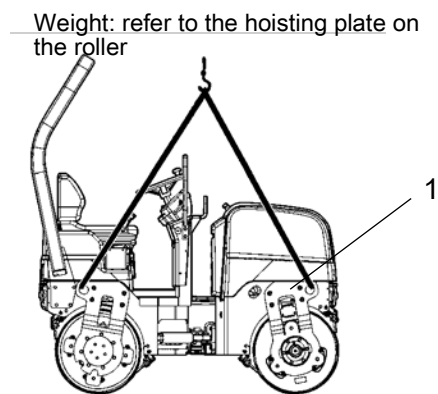

Fig. Roller prepared for lifting
 1. Hoisting plate

Lifting the roller



The machine's gross weight is specified on the hoisting plate (1). Refer also to the Technical specifications.



Lifting gear such as chains, steel wires, straps, and lifting hooks must be dimensioned and used in accordance with the applicable safety regulations for lifting devices.



Stand well clear of the hoisted machine! Make sure that the lifting hooks are properly secured.

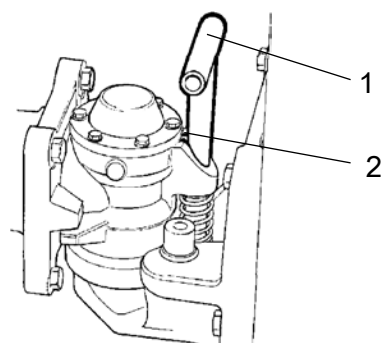

Fig. Articulated joint
 1. Locking arm
 2. Cotter pin in open position

Unlocking the articulation



Remember to unlock the articulation before operating.

Raise the locking arm (1) and turn it 180 degrees upward. Check that the cotter pin (2) is guided correctly into position for unlocking the articulation.

Securing 3500_D for loading

Securing the 3500_D vibratory roller from Mauldin for transport.

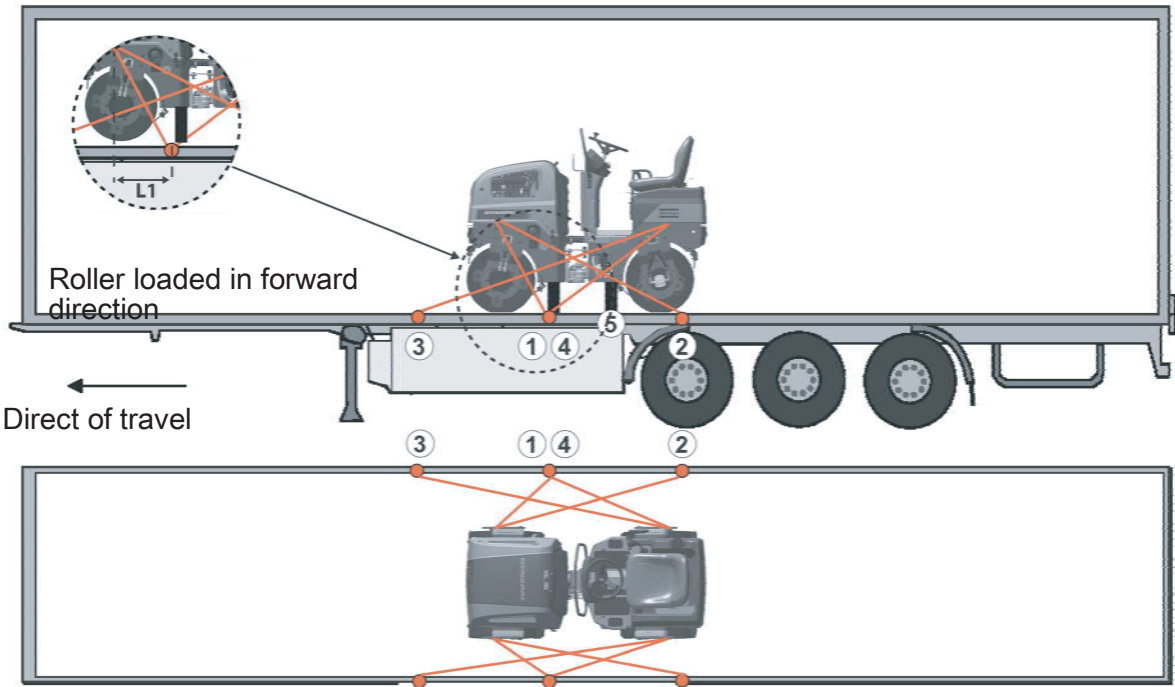

- 1 - 2 = double lashings, i.e. one lashing with two parts secured to two different lashing mounts,
- 3 - 4 symmetrically located on the right and left sides.
- 5 = rubber

The lashings' permitted distance interval in meters		
(1 - 4: Double lashings, LC at least 1.7 tonnes (1700 daN), S _{TF} 300 kg (300daN))		
Double L ₁ - L ₂	Double L ₃ - L ₄	
0,6 - 3,0	0,1 - 3,0	

The distance L₁ above is between points D and E. D is the projected point directly at right angles laterally in relation to the edge of the platform from the lashing mount C on the roller. E is the lashing mount at the edge of the platform. L₂ - L₃ have a corresponding relationship.

Load carrier

- When loaded, the vibratory roller is centered laterally on the platform (± 5 cm).
- The parking brake is applied and in good working condition, and the articulated joint lock is closed.
- The drum is placed on a rubber liner, so that the static friction between the surfaces is at least 0.6.
- The contact surfaces must be clean, wet or dry, and free from frost, ice and snow.
- The lashing mounts on the load carrier have LC/MSL at least 2 tonnes.

Lashings

- The lashings comprise a lashing strap or chain with a permitted load (LC/MSL) of at least 1.7 tonnes (1,700 daN) and a pre-tension S_{TF} of at least 300 kg (300 daN). The lashings are re-tightened as required.
- Each of lashings 1-3 is either a double or two single lashings. A double lashing runs in a sling through a lashing point or around a machine part and down into two different mounts on the platform.
- Lashings in the same direction are placed in different lashing mounts on the trailer. Lashings that are pulled in opposite directions may be placed in the same lashing mount, however.
- The lashings are as short as possible.
- The lashing hooks must not lose grip if the lashings become slack.
- The lashings are protected against sharp edges and corners.
- The lashings are located symmetrically in pairs on the right and left sides.

Towing

The roller can be moved up to 300 meters (1,000 ft) using the instructions below.

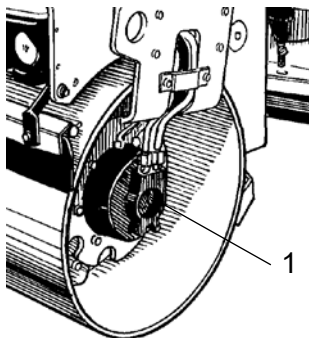

Fig. Drum
1. Propulsion motor, located left front and right rear.



Switch off the diesel engine and push in the emergency stop knob. Chock the drum to prevent the roller from moving when the brakes are disengaged.



The brakes in each propulsion motor must be mechanically released, as described below, before the roller is towed.

Releasing the brake

1. Remove the 2 plugs (191).

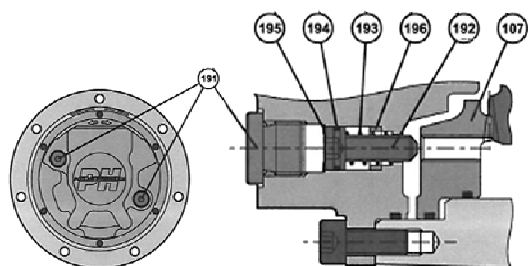
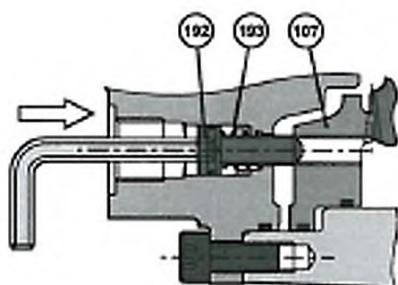

Figure. Releasing the brake



2. Press the screws (192) inwards to compress the springs (193) so that the screw reaches the brake (107) inner thread.

3. Tighten the two screws (192) alternately a little at a time so that the brake piston (107) loose (screw approximately 2 turns).



Tightening the screws (192) too hard can damage the inner mechanism



The machine should be started with reactivated brake.

Restored brake

Undo the two screws (192) alternately, and then insert the plugs (191).

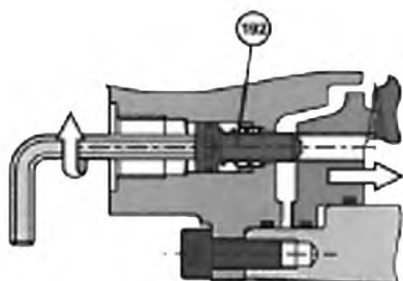

Tightening torque

Screws (192)

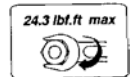
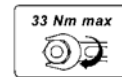

Plugs (191)

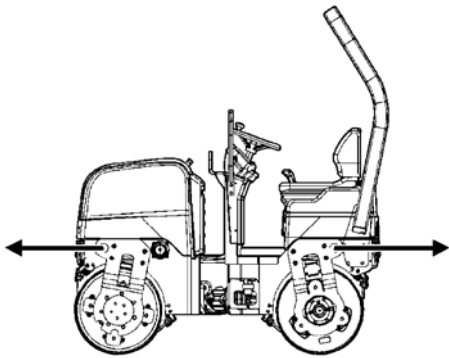
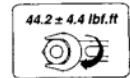

Fig. Towing the roller

Towing the roller



A towing bar must be used when towing, as the roller has no brakes and can only be slowed and stopped by the vehicle towing the roller.



The roller must be towed slowly, max. 3 km/h (2 mph) and for short distances only, max. 300 m (1000 ft).

When towing/recovering a machine, the towing device must be connected to both lifting holes. Pulling forces shall act longitudinally on the machine as illustrated. Max total towing force 50.8 kN (11,430 lbf), 25.4 kN (5,715 lbf) per fork.



Reset the steps taken for towing as described in the towing instructions on the previous page.

Operating instructions - Summary



1. Follow the **SAFETY INSTRUCTIONS** specified in the **Safety Manual**.
2. Make sure that all instructions in the **MAINTENANCE** section are followed.
3. Set the reserve/parking brake to its pulled-out position.
4. Move the forward/reverse lever to the **NEUTRAL** position.
5. Set the engine speed control to idle.
6. Start the engine and allow it to warm up.
7. Set the engine speed control to the operating position.



8. **Drive the roller. Operate the forward/reverse lever with care.**



9. **Test the brakes. Remember that the braking distance will be longer if the roller is cold.**
10. Use vibration only when the roller is in motion.
11. Check that the drums are thoroughly watered when watering is required.



12. **IN AN EMERGENCY:**
 - Press the **RESERVE/PARKING BRAKE BUTTON**
 - Hold the steering wheel firmly.
 - Brace yourself for a sudden stop.
13. Parking: - Switch off the machine and chock the drums.
14. When lifting: - Refer to the relevant section in the Instruction Manual.
15. When towing: - Refer to the relevant section in the Instruction Manual.
16. When transporting: - Refer to the relevant section in the Instruction Manual.
17. When recovering - Refer to the relevant section in the Instruction Manual.

Preventive maintenance

Complete maintenance is necessary for the machine to function satisfactorily and at the lowest possible cost.

The Maintenance section includes the periodic maintenance that must be carried out on the machine.

The recommended maintenance intervals assume that the machine is used in a normal environment and working conditions.

Acceptance and delivery inspection

The machine is tested and adjusted before it leaves the factory.

On arrival, before delivery to the customer, delivery inspection must be conducted as per the check list in the warranty document.

Any transport damage must be immediately reported to the transport company.

Warranty

The warranty is only valid if the stipulated delivery inspection and the separate service inspection have been completed as per the warranty document, and when the machine has been registered for starting under the warranty.

The warranty is not valid if damage has been caused by inadequate service, incorrect use of the machine, the use of lubricants and hydraulic fluids other than those specified in the manual, or if any other adjustments have been made without the requisite authorisation.

Maintenance - Lubricants and symbols



Always use high-quality lubricants and the amounts recommended. Too much grease or oil can cause overheating, resulting in rapid wear.

Fluid volumes

Drum	3,5 liters	3,7 qts
Ballast static drum *	65 liters	68,7 qts
Hydraulic reservoir	12 liters	3,2 gal
Diesel engine	1,3 liters without filter replacement	1,4 qts
	1,5 liters with filter replacement	1,6 qts

* In climates where there is a risk of freezing, see Coolant under the section Lubricants and Symbols.









Other fuel and lubricants are required when operating in areas with extremely high or extremely low ambient temperatures. See the 'Special instructions' chapter, or consult Mauldin.















Other fuel and lubricants are required when operating in areas with extremely high or extremely low ambient temperature. See the 'Special instructions' chapter, or consult Mauldin.

Maintenance - Lubricants and symbols

 ENGINE OIL	Air temperature -15°C - +50°C (5°F-122°F)	P/N 5580020624 (5 litres) P/N 5501522700 (20 litres)
 HYDRAULIC FLUID	Air temperature -15°C - +40°C (5°F-104°F)	P/N 9106230330 (20 litres) P/N 9106230331 (209 litres)
	Air temperature over +40°C (104°F)	Shell Tellus S2 V100
 BIOLOGICAL HYDRAULIC FLUID, PANOLIN	When it leaves the factory, the machine may be filled with biologically degradable fluid. The same type of fluid must be used when changing or topping up.	PANOLIN HLP Synth 46 (www.panolin.com)
BIOLOGICAL HYDRAULIC FLUID	When it leaves the factory, the machine may be filled with biologically degradable fluid. The same type of fluid must be used when changing or topping up.	BP Biohyd SE-S46
 DRUM OIL	Air temp. -15°C - +40°C (5°F-104°F)	P/N 4812008274 (5 litres), P/N 4812008275 (20 litres)
	Air temp. 0°C (32°F) - above +40°C (104°F)	Shell Spirax AX 85W/140, API GL-5
 FUEL	See engine manual. To comply with emission requirements for Kubota D722- E4B-KEA-2 you must use fuel with a low or extremely low Sulphur content.	-
 COOLANT	Anti-freeze protection down to about -37°C (-34.6°F)	GlycoShell/Carcoolant 774C (mixed 50/50 with water)

Maintenance - Lubricants and symbols

Maintenance symbols

	Engine, oil level		Air filter
	Engine, oil filter		Battery
	Hydraulic reservoir, level		Sprinkler
	Hydraulic fluid, filter		Sprinkler water
	Drum, oil level		Recycling
	Lubricating oil		Fuel filter

Maintenance - Maintenance schedule

Service and maintenance points

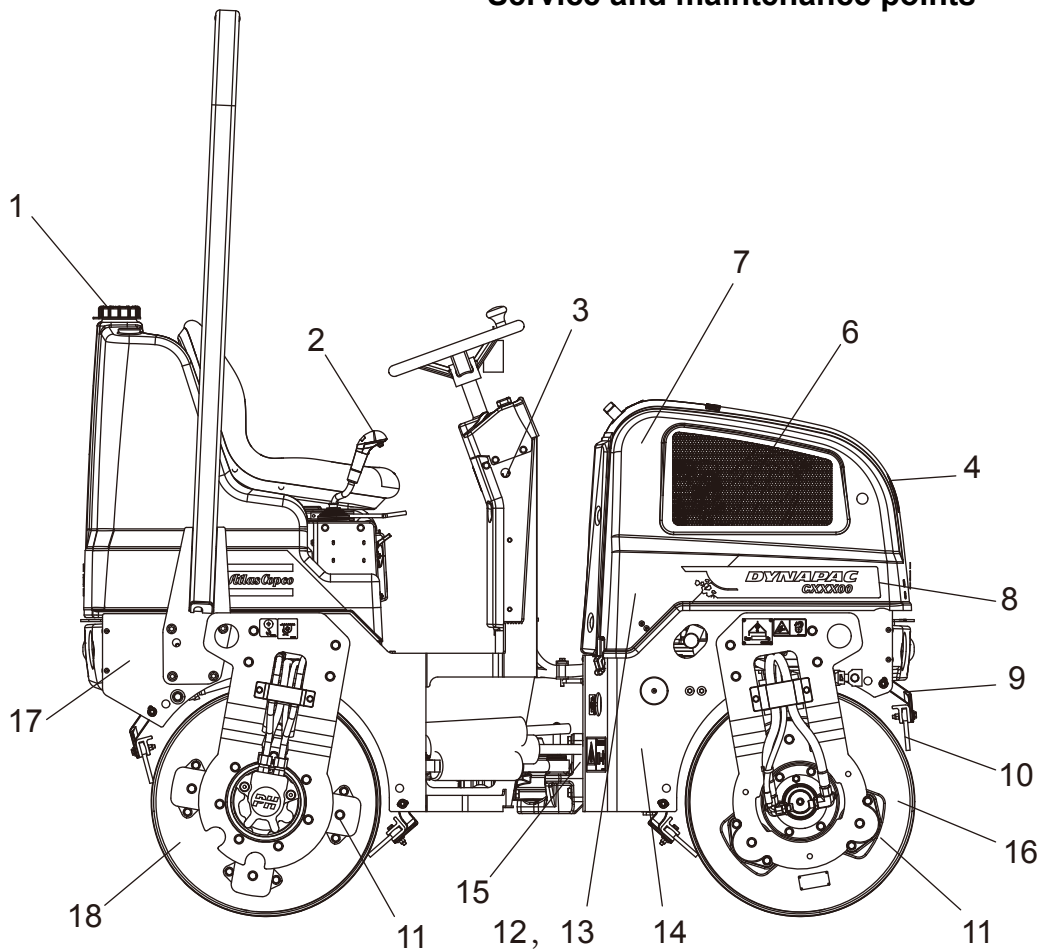

Fig. Service and maintenance points

- | | | |
|--------------------------|-------------------------------|--------------------------------------|
| 1. Water tank, filling | 7. Air cleaner | 13. Hydraulic fluid, filling |
| 2. Forward/Reverse lever | 8. Battery (maintenance free) | 14. Fuel tank, filling |
| 3. Reserve/parking brake | 9. Sprinkler | 15. Steering joint |
| 4. Cooler | 10. Scrapers | 16. Front drum, filling with oil |
| 6. Engine | 11. Rubber element | 17. ROPS, (option) |
| | 12. Hydraulic fluid filter | 18. Static drum, filling with water. |

Maintenance - Maintenance schedule

General

Periodic maintenance should be carried out after the number of hours specified. Use the daily, weekly etc. periods where number of hours cannot be used.



Remove all dirt before filling, when checking oils and fuel and when lubricating using oil or grease.



The manufacturer's instructions found in the engine manual also apply.



Where both operational hours and time intervals are specified, maintenance should be carried out at the point in time that occurs first.

Every 10 hours of operation (Daily)

Refer to the contents to find the page number of the sections referred to !

Pos. in fig	Action	Comment
1	Fill the water tank	
4	Check the coolant level	
4	Check for free circulation of cooling air	
6	Check the oil level in the engine	Refer to the engine manual
7	Check the engine's air cleaner	Refer to the engine manual
9	Check the sprinkler system	
10	Check the scraper setting	
13	Check the hydraulic reservoir level	
14	Refuel	
	Check the warning lamps	
	Test the brakes	

Maintenance - Maintenance schedule

FIRST 50 hours of operation

Refer to the contents to find the page number of the sections referred to !

Pos. in fig	Action	Comment
6	Change the engine oil and oil filter cartridge	Refer to the engine manual
12	Change the hydraulic fluid filter	
6	change fuel filter	Refer to the engine manual
	Check the belt tension on the hydraulic pump drive belt	

Every 50 hours of operation

Refer to the contents to find the page number of the sections referred to !

Pos. in fig	Action	Comment
6	Cleaning the fuel filter	Refer to the engine manual
6	Check the fuel pipes	Refer to the engine manual
7	Clean the air cleaner	Refer to the engine manual
11	Check the rubber elements and bolted joints	
6	check of fan belt tightness	Refer to the engine manual
	drain water separator	
	Check the belt tension on the hydraulic pump drive belt	
	Check and lubricant drum bearing seat	

Every 200 / 600 / 1400 / 1800 hours of operation

Refer to the contents to find the page number of the sections referred to !

Pos. in fig	Action	Comment
2	Check lubrication of controls and pivots	Lubricate as necessary
6	Change the engine oil and oil filter cartridge	Refer to the engine manual.
4	Clean the outside of radiator core	In dusty environments, as necessary
4	check of radiator hoses and clamp bands	
	check of intake air line	

Maintenance - Maintenance schedule

Every 400 / 800 / 1200 / 1600 hours of operation

Refer to the contents to find the page number of the sections referred to !

Pos. in fig	Action	Comment
6	Change the fuel filter	Refer to the engine manual
	Clean of water separator in fuel tank	
2	Check lubrication of controls and pivots	
6	Change the engine oil and oil filter cartridge	Refer to the engine manual.
4	Clean the outside of radiator core	In dusty environments, as necessary
4	check of radiator hoses and clamp bands	
6	check of intake air line	
6	Check the tension and condition of the fan belt	Replace if necessary
7	Replace the air cleaner filter element, check that hoses and connectors are tight	
13	Check the hydraulic reservoir cover/breather	
15	Check the condition of the articulation	
16	Check the oil level in the front drum	
	Check the belt tension on hydraulic pump drive system	

Maintenance - Maintenance schedule

Every 1000 hours of operation

Refer to the contents to find the page number of the sections referred to !

Pos. in fig	Action	Comment
2	Check lubrication of controls and pivots	Lubricate as necessary
4	Clean the outside/inside of radiator core	In dusty environments, as necessary
6	Change the fan belt	Refer to the engine manual
6	Change the engine oil and oil filter	Refer to the engine manual.
6	Check the engine valve clearances	Refer to the engine manual.
6	Check coolant freezing point	Change the coolant every other year
7	Replace the air cleaner filter element, check that hoses and connectors are tight	Refer to the engine manual
13	Check the hydraulic reservoir cover/breather	
12	Change the hydraulic fluid filter	
15	Check the condition of the articulation	
16	Change the oil in the front drum	
16	Check the oil level in the front drum	
	Replace valve cover gasket	
	Check the belt tension on hydraulic pump drive system	

Maintenance - Maintenance schedule

Every 2000 hours of operation

Refer to the contents to find the page number of the sections referred to !

Pos. in fig	Action	Comment
1	Drain and clean the water tank	
4	Clean the outside/inside of radiator core	In dusty environments, as necessary
6	Change the fan belt	Replace if necessary
6	Replace the fuel filter	Refer to the engine manual
6	Change the engine oil and oil filter	Refer to the engine manual
6	Change the breather valve on the engine	Refer to the engine manual
6	Check the engine valve clearances	Refer to the engine manual
6	Check coolant freezing point	Change the coolant every other year
7	Replace the air cleaner filter element, check that hoses and connectors are tight	Refer to the engine manual
12	Change the hydraulic fluid filter	
13	Check the hydraulic reservoir cover/breather	
13	Change the hydraulic fluid	
14	Drain and clean the fuel tank	
15	Check the condition of the articulation	
16	Change the oil in the front drum	
18	Change the water in the rear drum	
2	Check lubrication of controls and pivots	Lubricate as necessary
	Replace valve cover gasket	Refer to the engine manual
	Replace the hydraulic pump drive system belt	

Maintenance - Maintenance measures, before use



Park the roller on a level surface.
When checking and making adjustments, the engine should be switched off and the emergency/parking brake should be applied, if not otherwise specified.

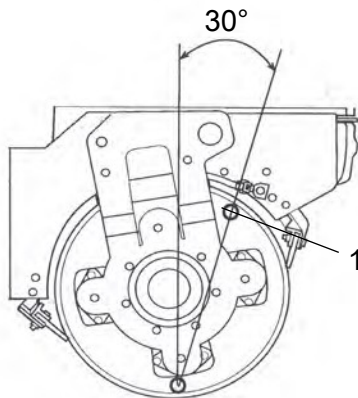

Fig. static drum
1. Water plug in position for filling.

Static drum - Filling with water



Unscrew the filler plug (1) and fill with pure water. The recommended volume of water in the drum is 65 liters. Where there is a risk of freezing, remember to add antifreeze.



Only additive: Environmentally-friendly antifreeze. Dosage according to the recommendations from the antifreeze supplier.

Maintenance, 10h



Park the roller on a level surface. When checking and making adjustments, the engine should be switched off and the emergency/parking brake should be applied, if not otherwise specified.



Water tank - Filling



Unscrew the tank cap (1), and fill with clean water.

Fill the water tank; it holds 175 liters.



Only additive: A small amount of environmentally friendly antifreeze.

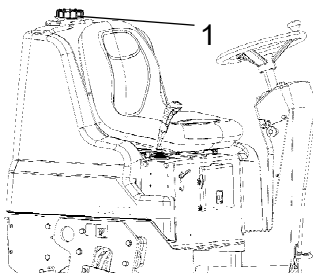

Fig. Water tank
1. Tank cap

Coolant level - Check

Remove the radiator cap (1), after the engine has completely cooled, and check to see that coolant reaches the supply port.



Refer to the engine manual for detailed instructions.

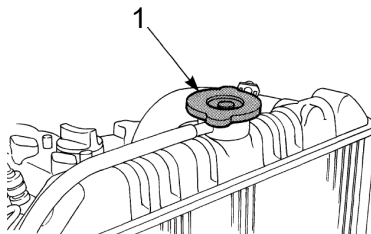

Fig. Radiator pressure cap

Air circulation - Check

Ensure that the diesel engine has free circulation of cooling air through the vents in the hood.

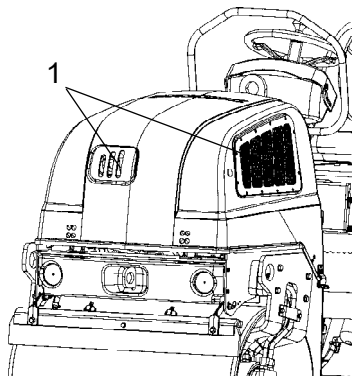

Fig. Engine cover
1. Cooling air grille/engine



Engine - Checking the oil level



Ensure that the engine is stopped before checking. Do not touch muffler or exhaust pipes while they are hot; Severe burns could result. Read safety instruction from Engine Manufacturer.

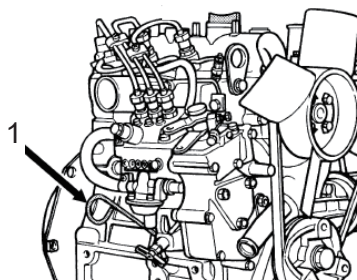

Fig. Engine cover
1. Cooling air grille/engine

Check the engine oil level before starting or more than 5 minutes after stopping the engine.

- Remove the oil level gauge, wipe it clean and reinsert it.
- Take the oil level gauge out again, and check the oil level.



Refer to the engine manual for detailed instructions.

Air cleaner - Check

As the element of the air cleaner employed on this engine is a dry type, never apply oil to it.

Open the evacuator valve once a week under ordinary conditions - or daily when used in a dusty place - to get rid of large particles of dust and dirt.



Refer to the engine manual for detailed instructions.

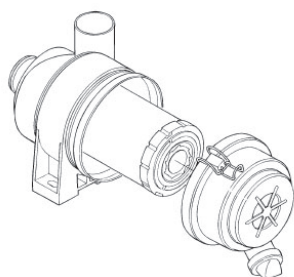

Fig. Air cleaner



Sprinkler system - Check, cleaning

Check that the holes in the sprinkler pipe (1) are not clogged, clean if necessary.

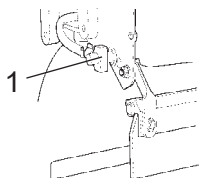

Fig. Sprinkler system
1. Sprinkler pipes with holes for water.

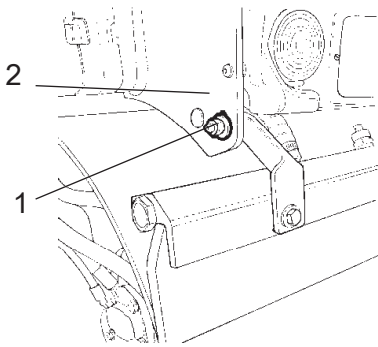

Fig. Front scrapers in transport position

- 1. Locking nut
- 2. Frame side

Scrapers - Check, adjustment

Make sure that the scrapers are undamaged. Adjust the scrapers if necessary in the following way:

For firmer application of the scraper, undo the locking nut (2) and turn it to the right until the desired application is achieved.

Lock this setting by tightening the locking nut against the frame side (2).

Adjust the pressure on both scraper brackets.

To set a lower scraper pressure, adjust in the reverse order to the above.



Hydraulic reservoir - Check/venting

Unscrew and make sure that the reservoir cap is not blocked. Air must have unobstructed passage through the cap in both directions.

If blocked in either direction, clean with a little diesel oil and blow with compressed air until unblocked or replace the cap with a new one.



Wear eye protectors and gloves when working with compressed air.

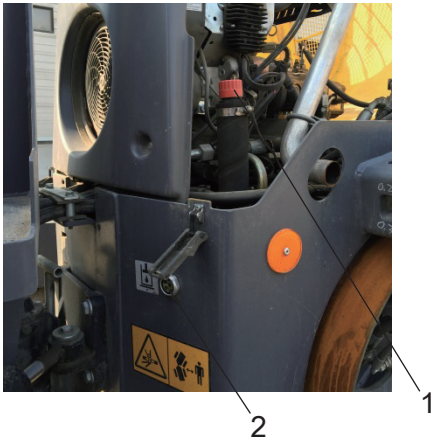

Figure. Under the engine compartment

- 1. Hydraulic fluid tank cap
- 2. Hydraulic oil level



Refueling

Refuel the tank every day before starting work. Open the tank cap and fill through the filler pipe (1).



Never refuel while the engine is running. Do not smoke and avoid spilling fuel.



Stop the engine. Short-circuit (press) the filler gun against the filler pipe (1) while refuelling.

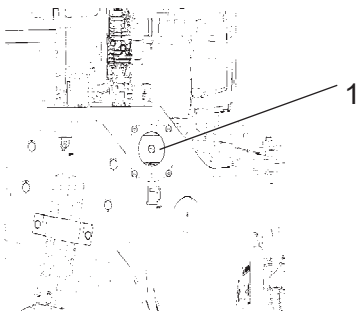

Fig. Left side

- 1. Filler pipe/cap



Figure. Control panel.
3. Parking brake
5. Control panel

Warning lamps - Check

Check that the warning lamps on the control panel (5) function.



Brakes - Check



Check the brakes by carrying out the following:

Drive the roller slowly forwards.

Activate parking brake (3). The brake warning lamp (5) should light and the roller should stop.

After testing the brakes, set the forward/reverse lever in neutral.

Deactivate the parking brake (3).

The roller can now be started.

Refer also to the section in the manual on operation.

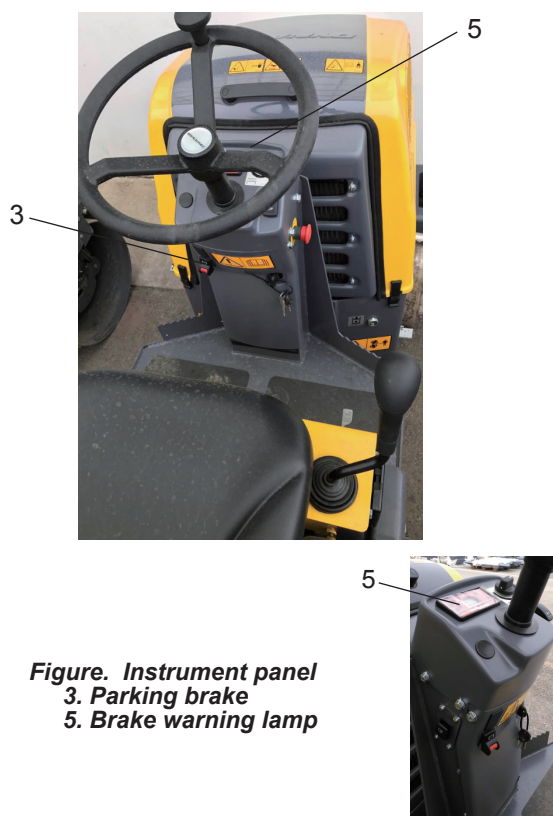

Figure. Instrument panel
3. Parking brake
5. Brake warning lamp

Maintenance - First 50h



Park the roller on a level surface. When checking and making adjustments, the engine should be switched off and the emergency/parking brake should be applied, if not otherwise specified.



Check that the engine cover is fully open before carrying out work underneath it.



Engine oil and oil filter cartridge - Change



Do not drain oil after running the engine. Allow engine to cool down sufficiently.



Switch off the engine and remove the key.



Take great care when draining fluids and oils. Wear protective gloves and goggles.

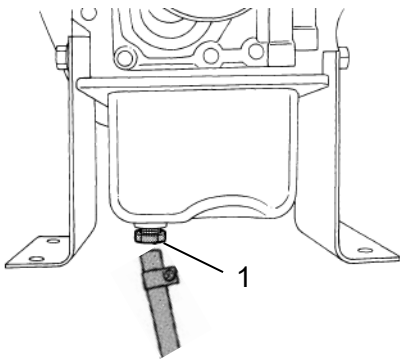

Fig 1. Oil drain plug

Remove the drain plug (1) at the bottom of the engine, and drain all the old oil. Drain oil easier and completely while the engine is hot.

Add new engine oil up to the upper limit of the oil level gauge.

Replace the oil filter cartridge (2)

Remove the old oil filter cartridge with a filter wrench.

Apply a film of oil to the gasket for the new cartridge.

Screw in the cartridge by hand. When the gasket contacts the seal surface, tighten the cartridge enough by hand.

After the new cartridge has been replaced, the engine oil level normally decreases a little.

Run the engine for a while and check oil leaks through the seal before checking the engine oil level.

Add oil if necessary.



Dispose of the old filter carefully.

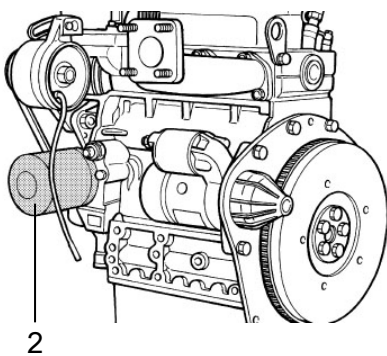

Fig 2. Oil filter cartridge



Hydraulic fluid filter - Change



Fig. Engine compartment, left side
1. Hydraulic fluid filter



Remove the filter (1) and deliver to special waste handling. This is a single-use filter and cannot be cleaned.

Thoroughly clean the filter holder sealing surface.

Apply a thin coat of fresh hydraulic fluid to the rubber gasket on the new filter.

Screw the filter on by hand, firstly until the filter gasket makes contact with the filter base. Then rotate a further ½ turn.



Do not over-tighten. The seal can be damaged.



Dispose of the old filter carefully.



Fuel filter - Change

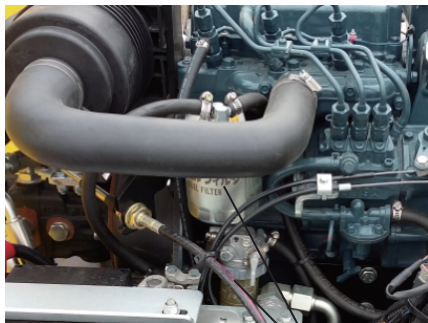

Fig. Fuel filter
1



Switch off the engine and remove the key.



Use caution. Wear gloves.

Replace the fuel filter (1).



Refer to the engine manual for detailed instructions.



Dispose of the old filter carefully.

Belt tension on the hydraulic pump drive belt - Check

If the hydraulic pump drive belt can be pressed in 5-6 mm between the pulleys with a force of 50 Nm, then the belt is correctly tensioned.

Do as follows to tension the belt:

- Undo the screws (1) and (2).
- Press over the hydraulic pump so that the belt tensions to the specified extent.
- Tighten screw (1) and then screw (2).
- Check that the belt still has the correct tension after tightening.

Replace the belt when necessary, or after 2000 h.

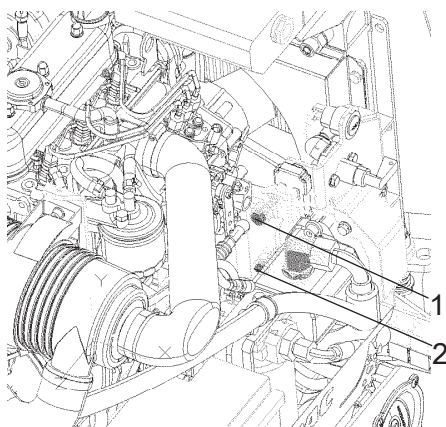

Fig. Engine compartment
1. Screw
2. Screw

Maintenance - 50h



Park the roller on a level surface. When checking and making adjustments, the engine should be switched off and the emergency/parking brake should be applied, if not otherwise specified.



Check that the engine cover is fully open before carrying out work underneath it.

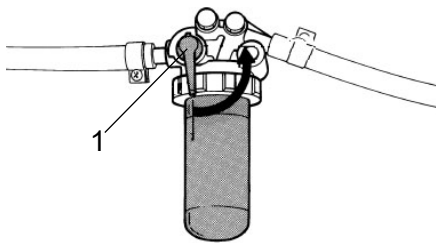

Fig. Fuel filter
1. Fuel filter lever

Fuel filter - Clean



Switch off the engine and remove the key.



Use caution. Wear gloves.

- Close the fuel filter lever (1).
- Remove the top cap, and rinse the inside with diesel fuel.
- Take out the element, and rinse it with diesel fuel.
- After cleaning, reinstall the fuel filter, keeping out of dust and dirt.
- Air-bleed the injection pump.



Refer to the engine manual for detailed instructions.

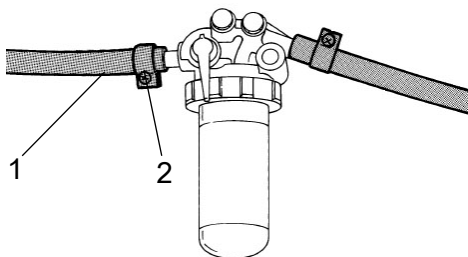

Fig. Fuel filter
1. Fuel pipe
1. Clamp band

Fuel pipes- Check



Check or replace the fuel pipes after stopping the engine. Broken fuel pipes can cause fires.

If the clamp band (2) is loose, apply oil to the screw of the band, and tighten the band securely.

Check the fuel pipe (1). Replace if wear or damage are found.



Refer to the engine manual for detailed instructions.

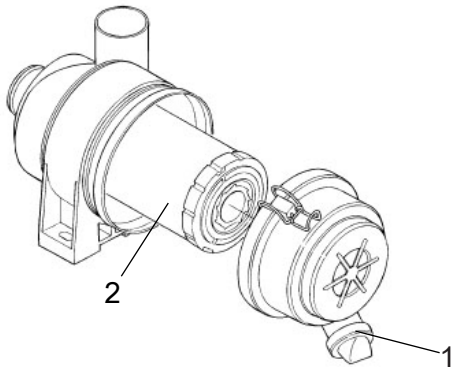

Fig. Air cleaner
 1. Evacuator valve
 2. Element

Air cleaner - Clean

Open the evacuator valve (1) to get rid of large particles of dust and dirt.

Wipe the inside air cleaner clean with cloth or like if it is dirty or wet.
 Avoid touching the element (2) except when cleaning.

When dry dust adheres to the element (2), blow compressed air from the inside turning the element (2). Pressure of compressed air must be under 205 kPa (2.1 kgf/cm², 30 psi).

! Refer to the engine manual for detailed instructions.

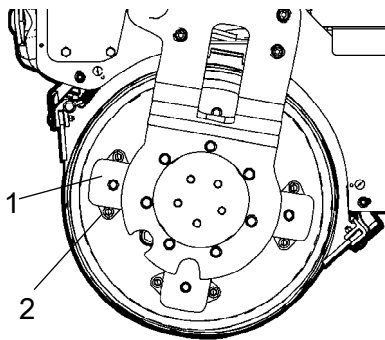

Fig. Drum suspension
 1. Rubber element
 2. Fastening screws

Rubber elements and fastening screws - Check

Check all the rubber elements (1), and replace all the elements if more than 20% of them on one side of the drum are cracked deeper than 10-15 mm.

Use a the blade of a knife or pointed object to check.

Check also that the screw fasteners (2) are tightened.

! The screws on the rubber elements are sealed with Loctite. Check the rubber elements on both sides of the roller.

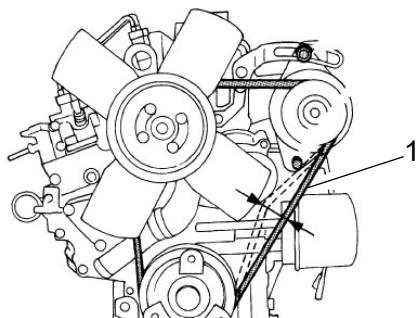

Fig 1. Fan belt

Fan belt tension - Check

! Be sure the reinstall the detached safety shield after maintenance or checking.

! Use caution. Wear gloves.

Stop the engine and remove the key.

Apply moderate thumb pressure to belt between the pulleys to check if the fan belt (1) tension is correct.

! Refer to the engine manual for detailed instructions.

Water separator - Drain



Switch off the engine and remove the key.



Use caution. Wear gloves.



Refer to the engine manual for detailed instructions.

Belt tension on the hydraulic pump drive belt - Check

If the hydraulic pump drive belt can be pressed in 5-6 mm between the pulleys with a force of 50 Nm, then the belt is correctly tensioned.

Do as follows to tension the belt:

- Undo the screws (1) and (2).
- Press over the hydraulic pump so that the belt tensions to the specified extent.
- Tighten screw (1) and then screw (2).
- Check that the belt still has the correct tension after tightening.

Replace the belt when necessary, or after 2000 h.

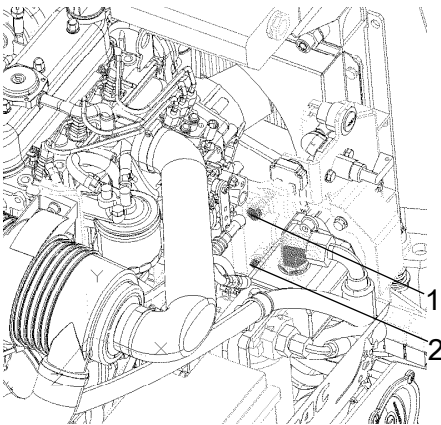

Fig. Engine compartment
1. Screw
2. Screw

Drum bearing seat - Check and lubrication

Drum bearing seat, which located on the left side of the rear drum. Check the condition of the bearing seat, grease the bearing seat through the grease nipple (1).

Grease the bearing point with twenty to twenty-five strokes of hand-operated grease gun.

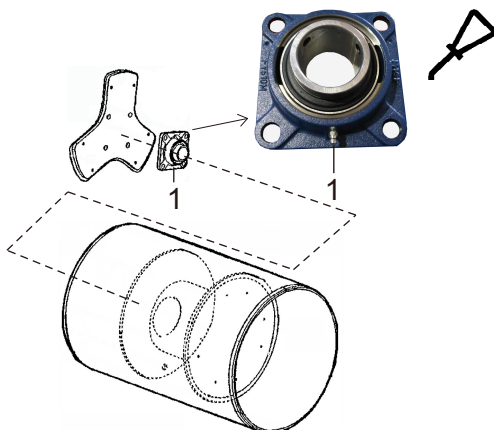

Figure. Drum bearing seat
1. Grease nipple

Maintenance - 200 / 600 / 1400 / 1800 h



*Park the roller on a level surface.
When checking and making adjustments, the engine should be switched off and the emergency/parking brake should be applied, if not otherwise specified.*



Check that the engine cover is fully open before carrying out work underneath it.



Forward/Reverse controls and joints - Check and lubrication

Unscrew the protective plate. Check the friction on the forward/reverse lever. The friction nut (1) should be applied with sufficient pressure to keep the forward/reverse lever in the set position during operation.

If the lever gets stiff after prolonged use, lubricate the lever at the bearing bushings and at the cable with a few drops of oil at each place.

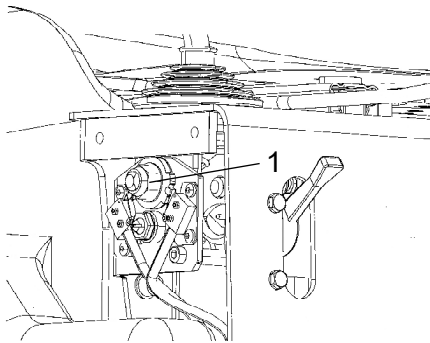

Figure. Forward/reverse lever
1. Friction nut

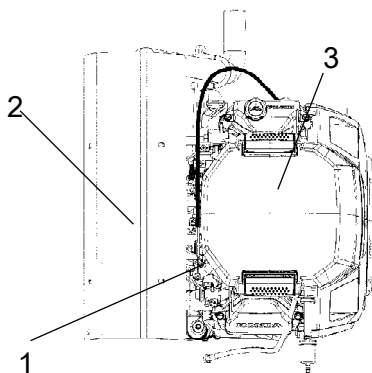

Fig. Engine compartment
1. F/R lever cable
2. Heat cover
3. Air filter

If the forward/reverse lever still is stiff after the above adjustments, lubricate the other end of the control cable with a few drops of oil. The cable is located on the top of the propulsion pump.

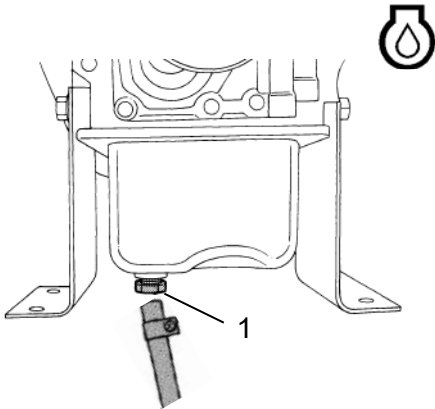

Fig 1. Oil drain plug

Engine oil and oil filter cartridge - Change



Do not drain oil after running the engine. Allow engine to cool down sufficiently.



Switch off the engine and remove the key.



Take great care when draining fluids and oils. Wear protective gloves and goggles.

Remove the drain plug (1) at the bottom of the engine, and drain all the old oil. Drain oil easier and completely while the engine is hot.

Add new engine oil up to the upper limit of the oil level gauge.

Replace the oil filter cartridge (2)

Remove the old oil filter cartridge with a filter wrench.

Apply a film of oil to the gasket for the new cartridge.

Screw in the cartridge by hand. When the gasket contacts the seal surface, tighten the cartridge enough by hand.

After the new cartridge has been replaced, the engine oil level normally decreases a little.

Run the engine for a while and check oil leaks through the seal before checking the engine oil level. Add oil if necessary.



Dispose of the old filter carefully.

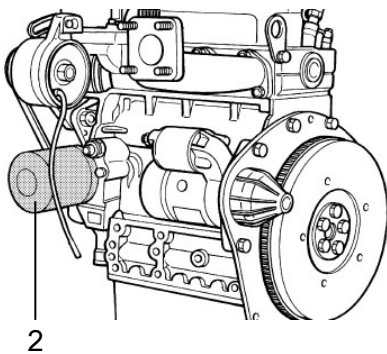

Fig 2. Oil filter cartridge

Outside radiator core - Clean



Be sure to reinstall the detached safety shield after maintenance or checking.



Use caution. Wear gloves.

If dust is between the fin and tube, wash it away with running water.



Refer to the engine manual for detailed instructions.

Radiator hoses and clamp bands - Check



Be sure to reinstall the detached safety shield after maintenance or checking.



Use caution. Wear gloves.

Check to see if radiator hoses are properly fixed.

If hose clamps are loose or water leaks, tighten hose clamp securely.



Refer to the engine manual for detailed instructions.

Intake air line - Check



Be sure to reinstall the detached safety shield after maintenance or checking.



Use caution. Wear gloves.



Refer to the engine manual for detailed instructions.

Maintenance - 400 / 800 / 1200 / 1600 h



Park the roller on a level surface. When checking and making adjustments, the engine should be switched off and the emergency/parking brake should be applied, if not otherwise specified.



Check that the engine cover is fully open before carrying out work underneath it.

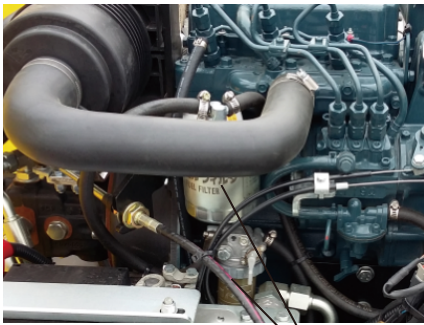

Fig. Fuel filter

1

Fuel filter - Change



Switch off the engine and remove the key.



Use caution. Wear gloves.

Replace the fuel filter every 400 hours of operation.



Refer to the engine manual for detailed instructions.



Dispose of the old filter carefully.

Water separator in fuel tank - Clean



Switch off the engine and remove the key.



Use caution. Wear gloves.

Taken out cleaning operation of water separator in fuel tank every 400 hours.



Refer to the engine manual for detailed instructions.



Forward/Reverse controls and joints - Check and lubrication

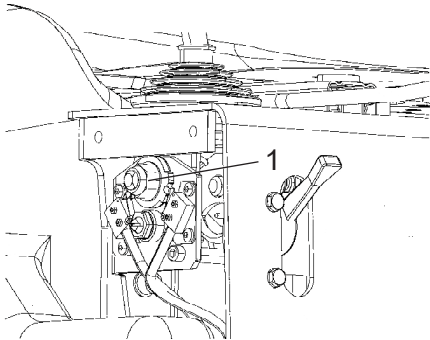

Figure. Forward/reverse lever
1. Friction nut

Unscrew the protective plate. Check the friction on the forward/reverse lever. The friction nut (1) should be applied with sufficient pressure to keep the forward/reverse lever in the set position during operation.

If the lever gets stiff after prolonged use, lubricate the lever at the bearing bushings and at the cable with a few drops of oil at each place.

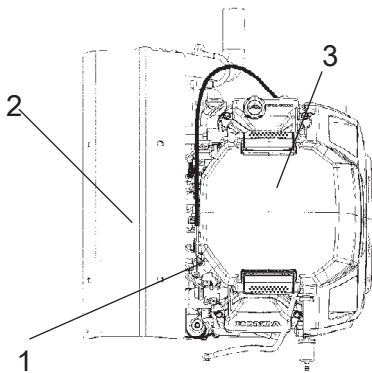

Fig. Engine compartment
1. F/R lever cable
2. Heat cover
3. Air filter

If the forward/reverse lever still is stiff after the above adjustments, lubricate the other end of the control cable with a few drops of oil. The cable is located on the top of the propulsion pump.



Engine oil and oil filter cartridge - Change

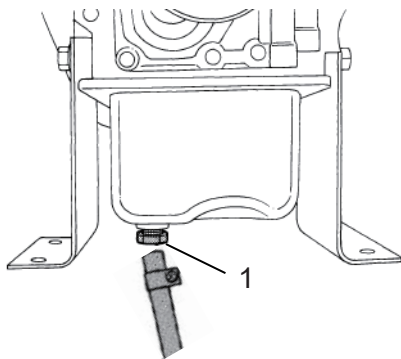

Fig 1. Oil drain plug



Do not drain oil after running the engine.
Allow engine to cool down sufficiently.



Switch off the engine and remove the key.



Take great care when draining fluids and oils.
Wear protective gloves and goggles.

Remove the drain plug (1) at the bottom of the engine, and drain all the old oil. Drain oil easier and completely while the engine is hot.

Add new engine oil up to the upper limit of the oil level gauge.

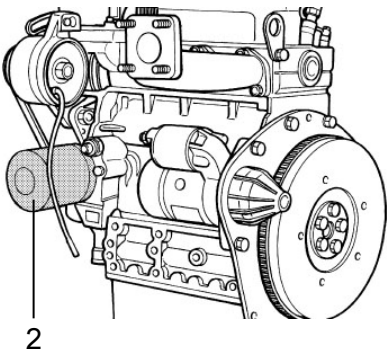

Fig 2. Oil filter cartridge

Replace the oil filter cartridge (2)

Remove the old oil filter cartridge with a filter wrench.

Apply a film of oil to the gasket for the new cartridge.

Screw in the cartridge by hand. When the gasket contacts the seal surface, tighten the cartridge enough by hand.

After the new cartridge has been replaced, the engine oil level normally decreases a little.

Run the engine for a while and check oil leaks through the seal before checking the engine oil level. Add oil if necessary.



Dispose of the old filter carefully.

Outside radiator core - Clean



Be sure the reinstall the detached safety shield after maintenance or checking.



Use caution. Wear gloves.

If dust is between the fin and tube, wash it away with running water.



Refer to the engine manual for detailed instructions.

Radiator hoses and clamp bands - Check



Be sure the reinstall the detached safety shield after maintenance or checking.



Use caution. Wear gloves.

Check to see if radiator hoses are properly fixed.

If hose clamps are loose or water leaks, tighten hose clamp securely.

Replace hoses and tighten hose clamps securely, if radiator hoses are swollen, hardened or cracked.



Refer to the engine manual for detailed instructions.

Air intake line - Check

 **Be sure to reinstall the detached safety shield after maintenance or checking.**

 **Use caution. Wear gloves.**

 Refer to the engine manual for detailed instructions.

Fan belt tension - Check

 **Be sure to reinstall the detached safety shield after maintenance or checking.**

 **Use caution. Wear gloves.**

Stop the engine and remove the key.

Apply moderate thumb pressure to belt between the pulleys to check if the fan belt (1) tension is correct.

 Refer to the engine manual for detailed instructions.

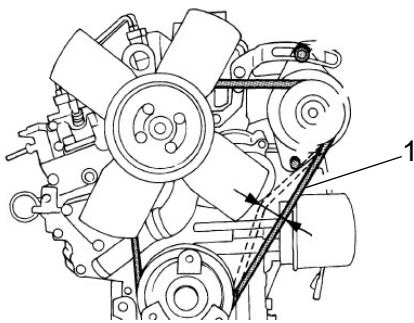

Fig 1. Fan belt

Air cleaner filter element - Change

 **Be sure to reinstall the detached safety shield after maintenance or checking.**

 **Use caution. Wear gloves.**

Replace the air cleaner filter element (1).

Check that hoses and connectors are tightened.

 Refer to the engine manual for detailed instructions.

 Dispose of the old filter carefully.

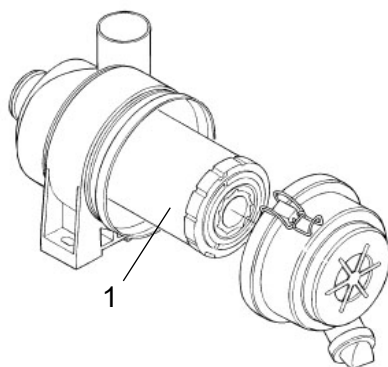

Fig. Air cleaner
1. Element

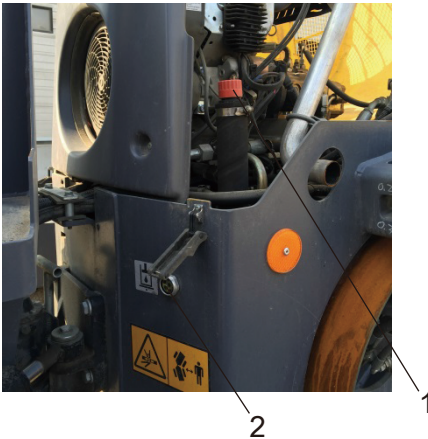

Figure. Under the engine compartment
 1. Hydraulic fluid tank cap
 2. Hydraulic oil level

Hydraulic reservoir - Check/venting

Unscrew and make sure that the reservoir cap is not blocked. Air must have unobstructed passage through the cap in both directions.

If blocked in either direction, clean with a little diesel oil and blow with compressed air until unblocked or replace the cap with a new one.



Wear eye protectors and gloves when working with compressed air.

Steering joint - Check

Inspect the steering joint to detect any damage or cracks.

Check and tighten any loose bolts.

Check also for any stiffness and play in the steering joint. Rectify if necessary.

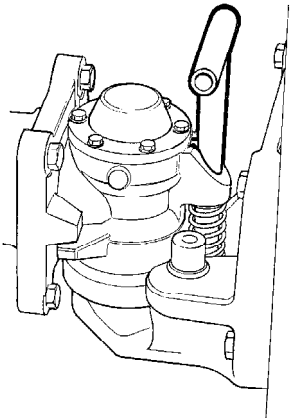

Fig. Steering joint



Front drum - Checking the oil level

Park the roller on a level surface, and drive the roller slowly until the oil plug (1) is in the middle of the semicircle shaped notch in the drum suspension.



Switch off the engine, disconnect the power and push in the reserve/parking brake knob.

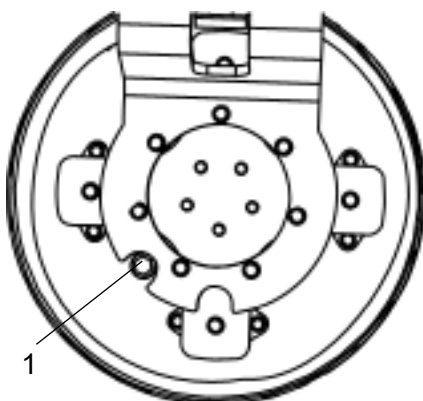

Fig. Front drum, drive side
 1. Oil plug

Unscrew the plug and check that the oil level reaches the hole's lower edge. If necessary, top off with fresh transmission fluid. See under the heading lubricants for correct fluid grade.

Clean the magnetic oil plug (1) from any metallic residue, and refit the plug.

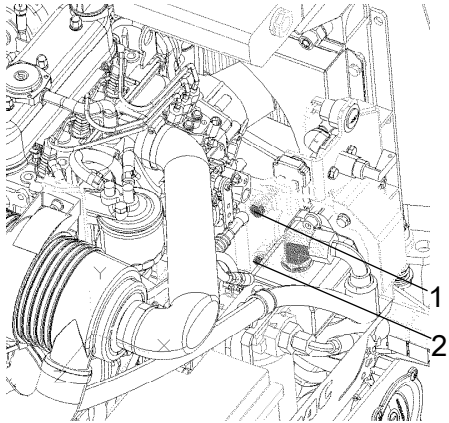

Fig. Engine compartment
1. Screw
2. Screw

Belt tension on the hydraulic pump drive belt - Check

If the hydraulic pump drive belt can be pressed in 5-6 mm between the pulleys with a force of 50 Nm, then the belt is correctly tensioned.

Do as follows to tension the belt:

- Undo the screws (1) and (2).
- Press over the hydraulic pump so that the belt tensions to the specified extent.
- Tighten screw (1) and then screw (2).
- Check that the belt still has the correct tension after tightening.

Replace the belt when necessary, or after 2000 h.

Maintenance - 1000h



Park the roller on a level surface. When checking and making adjustments, the engine should be switched off and the emergency/parking brake should be applied, if not otherwise specified.



Check that the engine cover is fully open before carrying out work underneath it.



Forward/Reverse controls and joints - Check and lubrication

Unscrew the protective plate. Check the friction on the forward/reverse lever. The friction nut (1) should be applied with sufficient pressure to keep the forward/reverse lever in the set position during operation.

If the lever gets stiff after prolonged use, lubricate the lever at the bearing bushings and at the cable with a few drops of oil at each place.

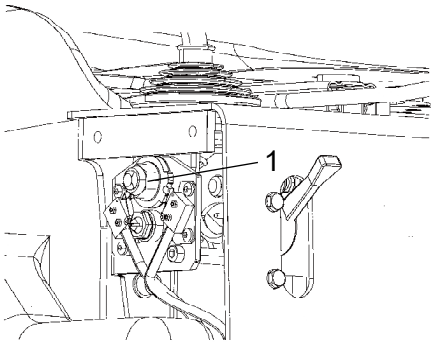

Figure. Forward/reverse lever
1. Friction nut

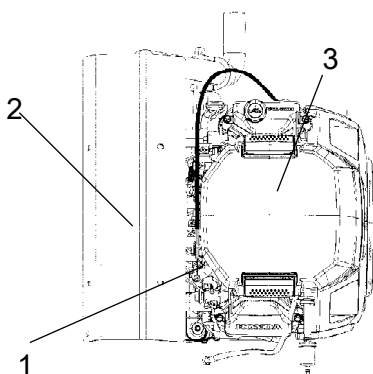

Fig. Engine compartment
1. F/R lever cable
2. Heat cover
3. Air filter

If the forward/reverse lever still is stiff after the above adjustments, lubricate the other end of the control cable with a few drops of oil. The cable is located on the top of the propulsion pump.

Outside / Inside radiator core - Clean

 **Be sure to reinstall the detached safety shield after maintenance or checking.**

 **Use caution. Wear gloves.**

- Outside radiator core:
If dust is between the fin and tube, wash it away with running water.

- Inside radiator core:
Use a radiator cleaning agent. This helps wash away scale deposit.

 Refer to the engine manual for detailed instructions.

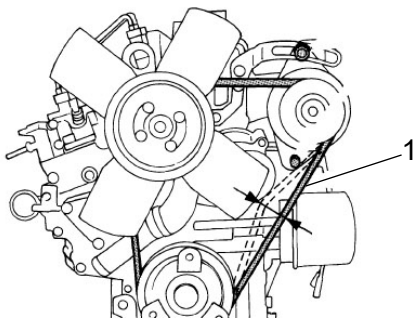

Fig 1. Fan belt

Fan belt - Change

 **Be sure to reinstall the detached safety shield after maintenance or checking.**

 **Use caution. Wear gloves.**

Stop the engine and remove the key.

Replace the fan belt.

 Refer to the engine manual for detailed instructions.

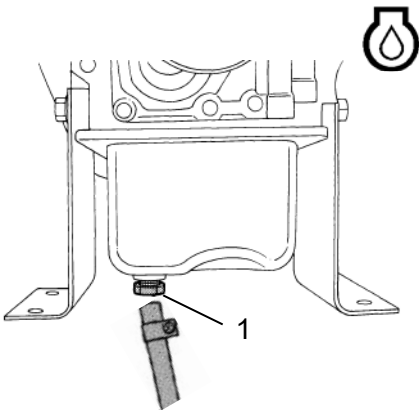

Fig 1. Oil drain plug

Engine oil and oil filter cartridge - Change



Do not drain oil after running the engine. Allow engine to cool down sufficiently.



Switch off the engine and remove the key.



Take great care when draining fluids and oils. Wear protective gloves and goggles.

Remove the drain plug (1) at the bottom of the engine, and drain all the old oil. Drain oil easier and completely while the engine is hot.

Add new engine oil up to the upper limit of the oil level gauge.

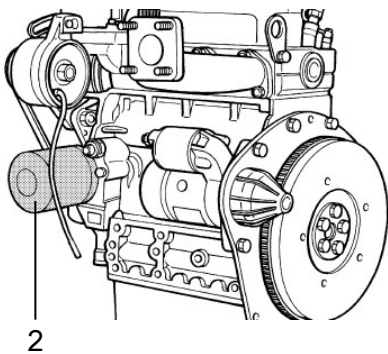

Fig 2. Oil filter cartridge

Replace the oil filter cartridge (2)

Remove the old oil filter cartridge with a filter wrench.

Apply a film of oil to the gasket for the new cartridge.

Screw in the cartridge by hand. When the gasket contacts the seal surface, tighten the cartridge enough by hand.

After the new cartridge has been replaced, the engine oil level normally decreases a little.

Run the engine for a while and check oil leaks through the seal before checking the engine oil level. Add oil if necessary.



Dispose of the old filter carefully.

Engine valve clearance - Check



Be sure to reinstall the detached safety shield after maintenance or checking.



Use caution. Wear gloves.



Refer to the engine manual for detailed instructions.

Coolant freezing point - Check

 **Be sure to reinstall the detached safety shield after maintenance or checking.**

 **Use caution. Wear gloves.**

Check the status of coolant temperature.

 Refer to the engine manual for detailed instructions.



Air cleaner filter element - Change

 **Be sure to reinstall the detached safety shield after maintenance or checking.**

 **Use caution. Wear gloves.**

Replace the air cleaner filter element (1).

Check that hoses and connectors are tightened.

 Refer to the engine manual for detailed instructions.

 Dispose of the old filter carefully.

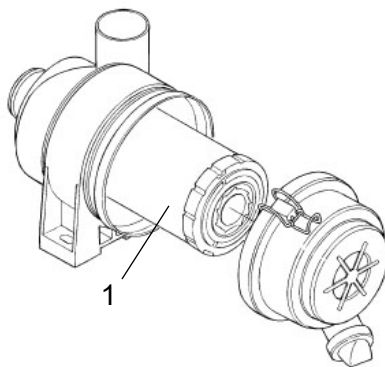

Fig. Air cleaner
1. Element



Hydraulic reservoir - Check/venting

Unscrew and make sure that the reservoir cap is not blocked. Air must have unobstructed passage through the cap in both directions.

If blocked in either direction, clean with a little diesel oil and blow with compressed air until unblocked or replace the cap with a new one.

 **Wear eye protectors and gloves when working with compressed air.**

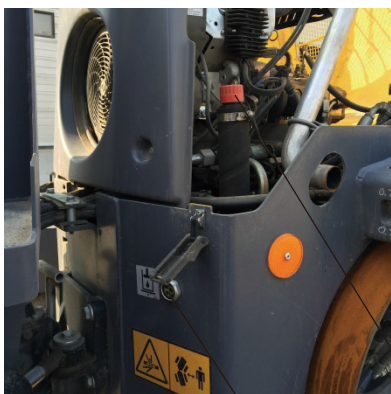

Figure. Under the engine compartment
1. Hydraulic fluid tank cap
2. Hydraulic oil level



Hydraulic fluid filter - Change



Fig. Engine compartment, left side
1. Hydraulic fluid filter



Remove the filter (1) and deliver to special waste handling. This is a single-use filter and cannot be cleaned.

Thoroughly clean the filter holder sealing surface.

Apply a thin coat of fresh hydraulic fluid to the rubber gasket on the new filter.

Screw the filter on by hand, firstly until the filter gasket makes contact with the filter base. Then rotate a further ½ turn.



Do not over-tighten. The seal can be damaged.



Dispose of the old filter carefully.

Steering joint - Check

Inspect the steering joint to detect any damage or cracks.

Check and tighten any loose bolts.

Check also for any stiffness and play in the steering joint. Rectify if necessary.

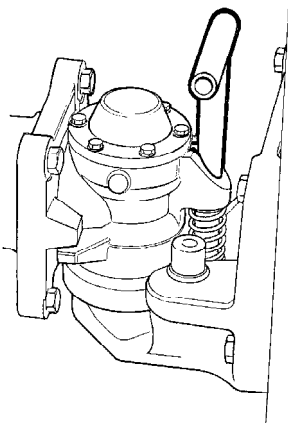

Fig. Steering joint



Front drum - Changing the oil

Loosen the oil plug (1) slightly, when it is in position for level check (2), so that it can subsequently be unscrewed by hand.

Park the roller on a level surface, and drive the roller slowly until the plug (1) is in the bottom position.



Switch off the engine, disconnect the power and push in the reserve/parking brake knob.

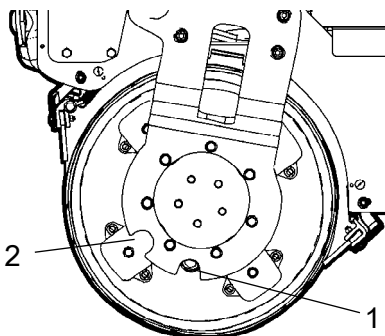

Fig. Drum, Drive side
1. Oil plug
2. Position for level check

Place a receptacle that will hold at least 4 liters (1 gal) under the plug.

Remove the plug (1) and let the oil run out.



Deliver the drained oil to special waste handling.



Front drum - Checking the oil level

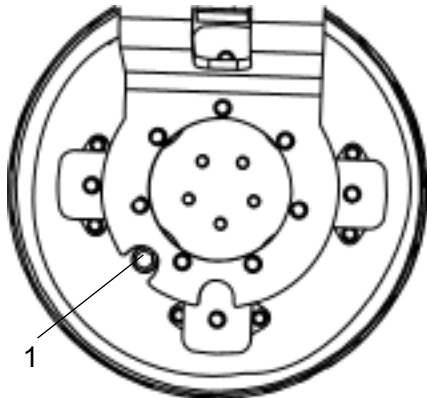

Fig. Front drum, drive side
1. Oil plug

Park the roller on a level surface, and drive the roller slowly until the oil plug (1) is in the middle of the semicircle shaped notch in the drum suspension.

! *Switch off the engine, disconnect the power and push in the reserve/parking brake knob.*

Unscrew the plug and check that the oil level reaches the hole's lower edge. If necessary, top off with fresh transmission fluid. See under the heading lubricants for correct fluid grade.

Clean the magnetic oil plug (1) from any metallic residue, and refit the plug.

Valve gasket - Change

! *Be sure to reinstall the detached safety shield after maintenance or checking.*

! *Use caution. Wear gloves.*

! Refer to the engine manual for detailed instructions.

Belt tension on the hydraulic pump drive belt - Check

If the hydraulic pump drive belt can be pressed in 5-6 mm between the pulleys with a force of 50 Nm, then the belt is correctly tensioned.

Do as follows to tension the belt:

- Undo the screws (1) and (2).
- Press over the hydraulic pump so that the belt tensions to the specified extent.
- Tighten screw (1) and then screw (2).
- Check that the belt still has the correct tension after tightening.

Replace the belt when necessary, or after 2000 h.

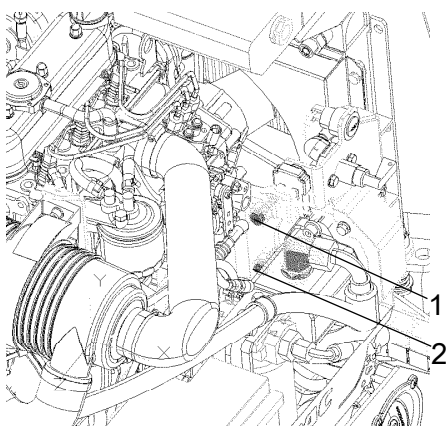

Fig. Engine compartment
1. Screw
2. Screw

Maintenance - 2000h



Park the roller on a level surface. When checking and making adjustments, the engine should be switched off and the emergency/parking brake should be applied, if not otherwise specified.



Check that the engine cover is fully open before carrying out work underneath it.



Water tank - Cleaning



Keep in mind that there is a risk of freezing in winter. Drain the tank, pump and lines.

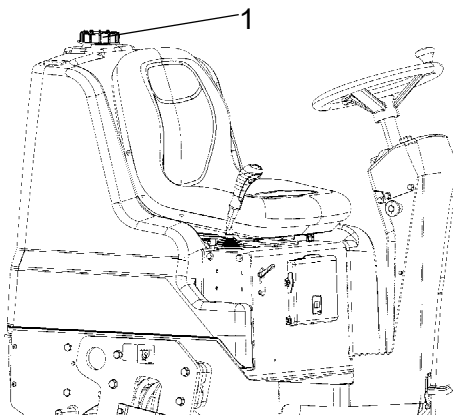

**Fig. Water tank
1. Cap**

Empty the tank.

Clean the tank with water and a suitable detergent for plastic surfaces.

Fill the tank with water and check that the sprinkler works.



The water tank is made of plastic (polyethylene) and is recyclable.

Outside / Inside radiator core - Clean



Be sure to reinstall the detached safety shield after maintenance or checking.



Use caution. Wear gloves.

- Outside radiator core:

If dust is between the fin and tube, wash it away with running water.

- Inside radiator core:

Use a radiator cleaning agent. This helps wash away scale deposit.



Refer to the engine manual for detailed instructions.

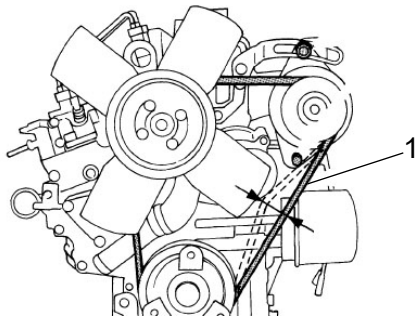

Fig 1. Fan belt

Fan belt - Change

 **Be sure to reinstall the detached safety shield after maintenance or checking.**

 **Use caution. Wear gloves.**

Stop the engine and remove the key.

Replace the fan belt.

 Refer to the engine manual for detailed instructions.

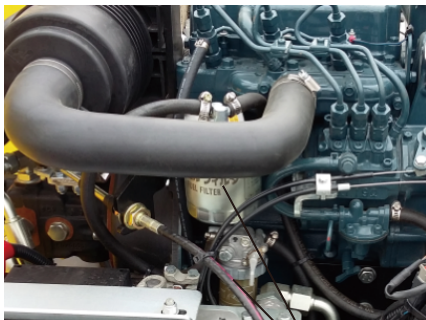

Fig. Fuel filter

Fuel filter - Change

 **Switch off the engine and remove the key.**

 **Use caution. Wear gloves.**

Replace the fuel filter (1).

 Refer to the engine manual for detailed instructions.

 Dispose of the old filter carefully.

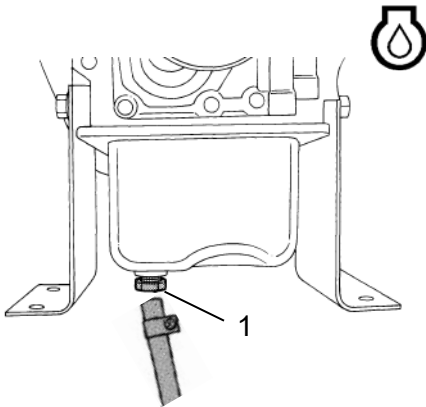

Fig 1. Oil drain plug

Engine oil and oil filter cartridge - Change



Do not drain oil after running the engine. Allow engine to cool down sufficiently.



Switch off the engine and remove the key.



Take great care when draining fluids and oils. Wear protective gloves and goggles.

Remove the drain plug (1) at the bottom of the engine, and drain all the old oil. Drain oil easier and completely while the engine is hot.

Add new engine oil up to the upper limit of the oil level gauge.

Replace the oil filter cartridge (2)

Remove the old oil filter cartridge with a filter wrench.

Apply a film of oil to the gasket for the new cartridge.

Screw in the cartridge by hand. When the gasket contacts the seal surface, tighten the cartridge enough by hand.

After the new cartridge has been replaced, the engine oil level normally decreases a little.

Run the engine for a while and check oil leaks through the seal before checking the engine oil level. Add oil if necessary.



Dispose of the old filter carefully.

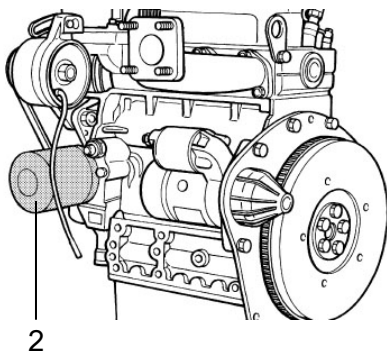

Fig 2. Oil filter cartridge

Engine breather valve - Change



Be sure the reinstall the detached safety shield after maintenance or checking.



Use caution. Wear gloves.

Change engine breather valve.



Refer to the engine manual for detailed instructions.



Fuel tank - Cleaning

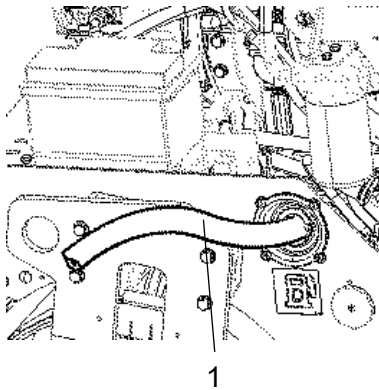

Fig. Fuel tank
1. Hose from external pump

It is easiest to clean the tank when it is almost empty.

Pump out any bottom sediment using an external pump.

To remove any additional bottom sediment, fill the tank with two liters of diesel, and then pump it out using the external pump.



Collect in a container which holds at least 28 liters and deliver to special waste handling.



Keep in mind fire risk when handling fuel.



The fuel tank is made of plastic (polyethylene) and is recyclable.

Engine valve clearance - Check



Be sure the reinstall the detached safety shield after maintenance or checking.



Use caution. Wear gloves.



Refer to the engine manual for detailed instructions.

Coolant freezing point - Check



Be sure the reinstall the detached safety shield after maintenance or checking.



Use caution. Wear gloves.

Check the status of coolant temperature.



Refer to the engine manual for detailed instructions.



Air cleaner filter element - Change



Be sure to reinstall the detached safety shield after maintenance or checking.



Use caution. Wear gloves.

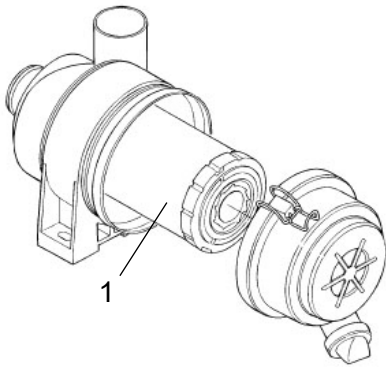

Fig. Air cleaner
1. Element

Replace the air cleaner filter element (1).
Check that hoses and connectors are tightened.



Refer to the engine manual for detailed instructions.



Dispose of the old filter carefully.



Hydraulic fluid filter - Change



Remove the filter (1) and deliver to special waste handling. This is a single-use filter and cannot be cleaned.



Fig. Engine compartment, left side
1. Hydraulic fluid filter

Thoroughly clean the filter holder sealing surface.

Apply a thin coat of fresh hydraulic fluid to the rubber gasket on the new filter.

Screw the filter on by hand, firstly until the filter gasket makes contact with the filter base. Then rotate a further 1/2 turn.



Do not over-tighten. The seal can be damaged.



Dispose of the old filter carefully.



Hydraulic reservoir - Check/venting

Unscrew and make sure that the reservoir cap is not blocked. Air must have unobstructed passage through the cap in both directions.

If blocked in either direction, clean with a little diesel oil and blow with compressed air until unblocked or replace the cap with a new one.



Wear eye protectors and gloves when working with compressed air.

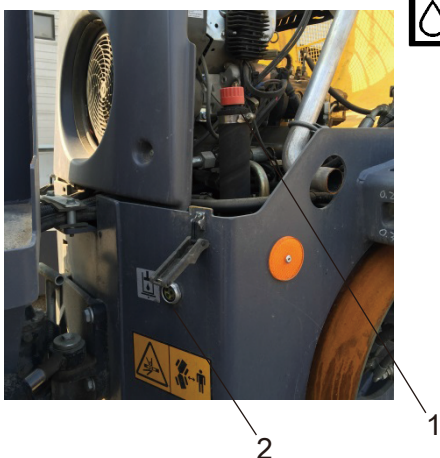

Figure. Under the engine compartment
1. Hydraulic fluid tank cap
2. Hydraulic oil level



Hydraulic reservoir - fluid change

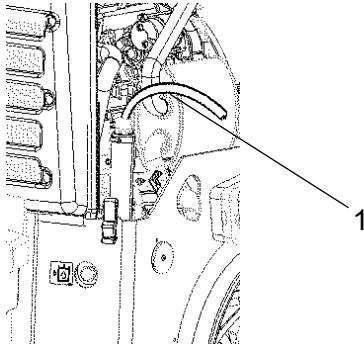

Fig. Hydraulic reservoir
1. Draining

Use an external drainage pump when draining/emptying the hydraulic reservoir.



Risk of burn injuries when draining hot oil. Wear protective gloves and goggles.

Unscrew the tank cap. Place the pump's suction hose in the filler/drain outlet in the hydraulic tank. Place the other hose in a container.



Use a receptacle that holds at least 15 liters (4 gal).

Start the pump so that it sucks out the fluid from the tank.

Check that the hose to the pump reaches the bottom of the hydraulic reservoir to ensure that as much of the fluid as possible is drained.



Collect the oil and deliver to special waste handling.

Fill up with the recommended hydraulic fluid to the correct level. Replace the cap on the tank and wipe clean.

Change the hydraulic fluid filter, see under heading 'Every 1000 hours of operation'.

Start the engine and operate the various hydraulic functions. Check the level in the reservoir and top off as required.

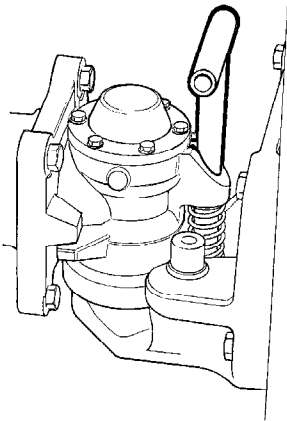

Fig. Steering joint

Steering joint - Check

Inspect the steering joint to detect any damage or cracks.

Check and tighten any loose bolts.

Check also for any stiffness and play in the steering joint. Rectify if necessary.



Front drum - Changing the oil

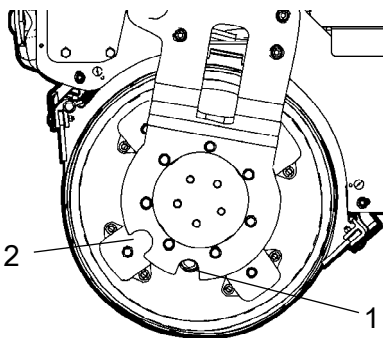

Fig. Drum, Drive side
1. Oil plug
2. Position for level check

Loosen the oil plug (1) slightly, when it is in position for level check (2), so that it can subsequently be unscrewed by hand.

Park the roller on a level surface, and drive the roller slowly until the plug (1) is in the bottom position.

 **Switch off the engine, disconnect the power and push in the reserve/parking brake knob.**

Place a receptacle that will hold at least 4 liters (1 gal) under the plug.

Remove the plug (1) and let the oil run out.

 Deliver the drained oil to special waste handling.



Forward/Reverse controls and joints - Check and lubrication

Unscrew the protective plate. Check the friction on the forward/reverse lever. The friction nut (1) should be applied with sufficient pressure to keep the forward/reverse lever in the set position during operation.

If the lever gets stiff after prolonged use, lubricate the lever at the bearing bushings and at the cable with a few drops of oil at each place.

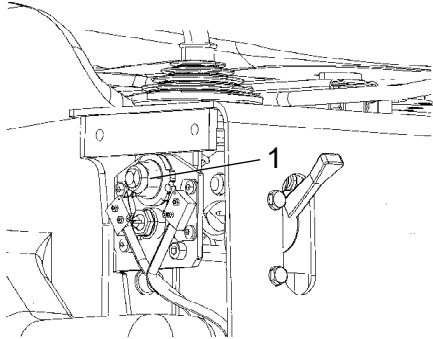

Figure. Forward/reverse lever
1. Friction nut

If the forward/reverse lever still is stiff after the above adjustments, lubricate the other end of the control cable with a few drops of oil. The cable is located on the top of the propulsion pump.

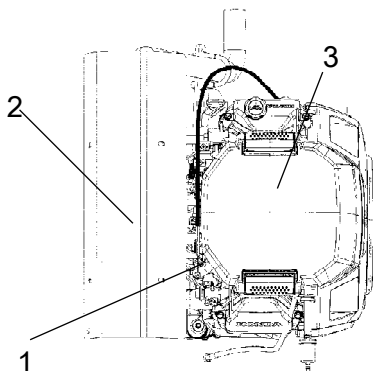

Fig. Engine compartment
1. F/R lever cable
2. Heat cover
3. Air filter

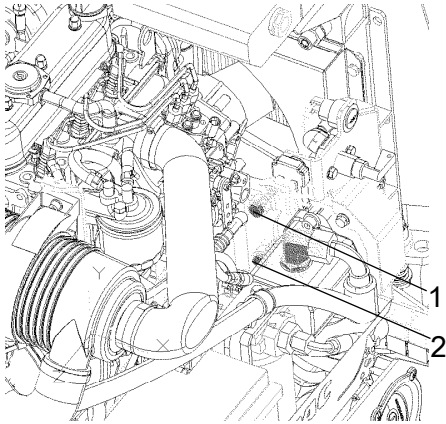

Fig. Engine compartment
1. Screw
2. Screw

Belt tension on the hydraulic pump drive belt - Check

If the hydraulic pump drive belt can be pressed in 5-6 mm between the pulleys with a force of 50 Nm, then the belt is correctly tensioned.

Do as follows to tension the belt:

- Undo the screws (1) and (2).
- Press over the hydraulic pump so that the belt tensions to the specified extent.
- Tighten screw (1) and then screw (2).
- Check that the belt still has the correct tension after tightening.

Replace the belt when necessary, or after 2000 h.

Disposal

Correctly sorted disposal must be carried out after replacing wear and spare parts and after the machine has been withdrawn from service (scrapped).

The materials must be sorted correctly according to metal, plastic, electronic scrap, various operating substances etc.

Any oily or greasy parts (hydraulic hoses, lube pipes etc.) must be treated separately.

Electric devices, accessories and packaging should be recycled in an environment-friendly manner.

Always observe the local regulations.