

Instruction manual

Operating & Maintenance

**Vibratory roller
3500_G**

**Engine
Honda GX630R**

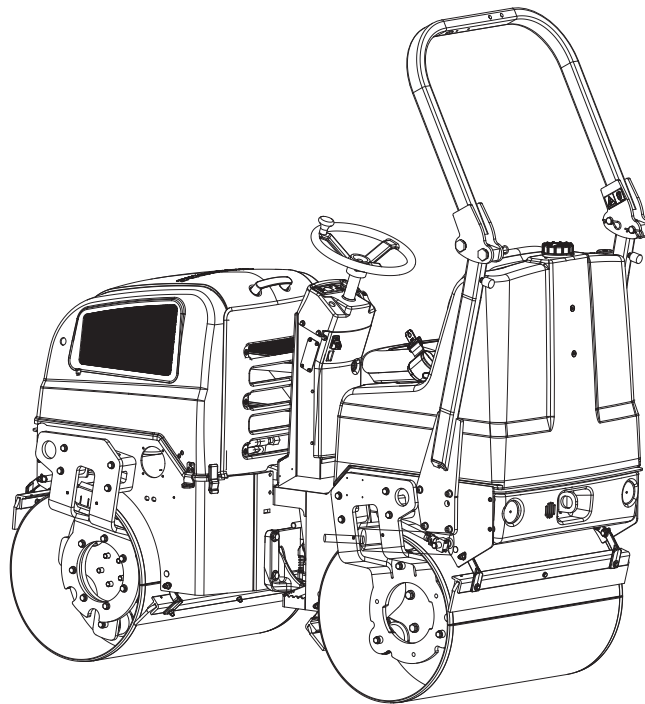

Translation of original instruction

*Reservation for changes
Printed in China*



Table of Contents

Introduction	1
The machine	1
Intended use	1
Warning symbols.....	1
Safety information	1
General	2
Safety - General instructions.....	3
Safety - when operating	5
Slopes	5
Driving near edges	6
Sitting position.....	7
Special instructions	9
Standard lubricants and other recommended oils and fluids	9
Higher ambient temperatures, above +40°C (104°F).....	9
Lower ambient temperature - Freeze risk	9
Temperatures.....	9
High pressure cleaning	9
Fire fighting	9
Roll Over Protective Structure (ROPS)	10
Battery handling	10
Jump starting.....	11
Technical specifications - Noise/Vibrations/Electrical	13
Vibrations - Operator station	13
Noise level.....	13
Technical specifications - Dimensions	15
Dimensions, side view.....	15
Dimensions, top view	16
Weights and volumes.....	17
Working capacity.....	17
General	18

Hydraulic system.....	18
Tightening torque	18
ROPS - bolts	19
Identification	19
Machine plate.....	19
Product identification number on the frame	20
Engine plates	21
Machine description- Decals.....	23
Location - decals	23
Safety decals.....	24
Info decals.....	25
Instruments/Controls	26
Locations - Instruments and controls	26
Function description	27
Electrical system.....	28
Relays and fuses on the machine	28
Operation	29
Before starting	29
Operator's seat - Adjusting.....	29
Sprinkler - Check	29
Parking brake	30
Emergency stop.....	30
Operator position.....	30
Starting	31
Starting the engine	31
Driving	32
Operating the roller	32
Vibration	33
Manual vibration - Switching on	33
Operating - Stopping.....	35
Braking	35

Normal braking.....	35
Reserve brake.....	36
Switching off.....	36
Parking.....	37
Chocking the drums.....	37
Long-term parking.....	39
Engine.....	39
Battery.....	39
Air cleaner, exhaust pipe.....	39
Sprinkler system.....	39
Fuel tank.....	39
Hydraulic reservoir.....	39
Steering cylinder, hinges, etc.....	40
Hoods, tarpaulin.....	40
Miscellaneous.....	41
Locking the articulation.....	41
Lifting the roller.....	41
Unlocking the articulation.....	41
Securing 3500_G for loading.....	42
Towing.....	43
Releasing the brake.....	43
Towing the roller.....	45
Operating instructions - Summary.....	47
Preventive maintenance.....	49
Acceptance and delivery inspection.....	49
Warranty.....	49
Maintenance - Lubricants and symbols.....	51
Maintenance symbols.....	53
Maintenance - Maintenance schedule.....	55
Service and maintenance points.....	55

General	56
Every 10 hours of operation (Daily).....	56
After the first 20 hours of operation.....	56
After the FIRST 50 hours of operation	57
Every 50 hours of operation	57
Every 100 hours of operation	57
Every 200 / 400 / 600 / 800 hours of operation	58
Every 500 hours of operation	58
Every 1000 hours of operation	59
Every 2000 hours of operation	60
Maintenance - Maintenance measures, before use.....	61
Static drum - Filling with water	61
Maintenance, 10h	63
Engine - Checking the oil level.....	63
Hydraulic reservoir, Level check - Filling.....	63
Refueling	64
Water tank - Filling	64
Sprinkler system - Check, cleaning.....	64
Air circulation - Check	65
Scrapers - Check, adjustment.....	65
Warning lamps - Check.....	65
Air cleaner - check	66
Maintenance - 20h	67
Engine oil and oil filter - Change	67
Maintenance - 50h	69
Brakes - Check.....	69
Air cleaner - cleaning	70
Rubber elements and fastening screws - Check.....	70
Drum bearing seat - Check and lubrication	70
Maintenance - 100h	71
Spark plug - Check and adjustment	71

Maintenance - 200 / 400 / 600 / 800 h	73
Spark plug - Replace.....	73
Engine's fuel filter - Check.....	74
Engine oil and oil filter - Change	75
Forward/Reverse controls and joints - Check and lubrication	76
Maintenance - 500h	77
Front drum - Checking the oil level	77
Hydraulic reservoir - Check/venting	78
Steering joint - Check.....	78
Air cleaner - replace insert	79
Maintenance - 1000h	81
Spark plug - Replace.....	81
Engine's fuel filter - Replace.....	82
Hydraulic fluid cooler - Cleaning (Option).....	82
Forward/Reverse controls and joints - Check and lubrication.....	83
Front drum - Checking the oil level	84
Hydraulic reservoir - Check/venting	84
Steering joint - Check.....	85
Air cleaner - replace insert	85
Hydraulic fluid filter - Change	86
Engine oil and oil filter - Change	86
Engine's fuel filter - Check.....	87
Maintenance - 2000h	89
Spark plug - Replace.....	89
Engine's fuel filter - Replace.....	90
Hydraulic fluid cooler - Cleaning (Option).....	90
Forward/Reverse controls and joints - Check and lubrication.....	91
Hydraulic reservoir - Check/venting	91
Steering joint - Check.....	92

Air cleaner - replace insert	92
Hydraulic fluid filter - Change	93
Engine oil and oil filter - Change	93
Hydraulic reservoir - fluid change.....	95
Front drum - Changing the oil	96
Water tank - Cleaning	96

Introduction

The machine

Mauldin 3500_G is a self-propelled vibratory tandem roller in the 1,6 metric tonnes class featuring 900 mm wide drums. The machine is equipped with drive, brakes, and vibration on both drums.

Intended use

3500_G is primarily used for smaller compaction works, such as minor roads, sidewalks, cycle ways and minor parking places.

Warning symbols



WARNING ! Marks a danger or a hazardous procedure that can result in life threatening or serious injury if the warning is ignored.



CAUTION ! Marks a danger or hazardous procedure that can result in damage to the machine or property if the warning is ignored.

Safety information



The safety manual supplied with the machine must be read by all roller operators. Always follow the safety instructions. Do not remove the manual from the machine.



Read the entire manual before starting the machine and before carrying out any maintenance.



Ensure good ventilation (extraction of air by fan) where the engine is run indoors.



Replace immediately the instruction manuals if lost, damaged or unreadable.



Prevent persons from entering or remaining in the danger area, i.e. a distance of at least 7 m (23 ft) in all directions from operating machines. The operator may allow a person to remain in the danger area, but should then observe caution and operate the machine only when the person is visible or has given clear indications of where he or she is.

CALIFORNIA

Proposition 65 Warning

Gasolin engine exhaust and some of its constituents are known to the State of California to cause cancer, birth defects, and other reproductive harm.

General

This manual contains instructions for machine operation and maintenance.

The machine must be correctly maintained for maximal performance.

The machine should be kept clean so that any leakages, loose bolts and loose connections are discovered at as early a point in time as possible.

Inspect the machine every day, before starting. Inspect the entire machine so that any leakages or other faults are detected.

Check the ground under the machine. Leakages are more easily detected on the ground than on the machine itself.



THINK ENVIRONMENT ! Do not release oil, fuel and other environmentally hazardous substances into the environment. Always send used filters, drain oil and fuel remnants to environmentally correct disposal.

This manual contains instructions for periodic maintenance normally carried out by the operator.



Additional instructions for the engine can be found in the manufacturer's engine manual.

Safety - General instructions

(Also read the safety manual)



1. **The operator must be familiar with the contents of the OPERATION section before starting the roller.**
2. **Ensure that all instructions in the MAINTENANCE section are followed.**
3. **Only trained and/or experienced operators are to operate the roller. Passengers are not permitted on the roller. Remain seated at all times when operating the roller.**
4. **Never use the roller if it is in need of adjustment or repair.**
5. **Only mount and dismount the roller when it is stationary. Use the intended grips and rails. Always use the three-point grip (both feet and one hand, or one foot and both hands) when mounting or dismounting the machine. Never jump down from the machine.**
6. **The ROPS (Roll Over Protective Structure) should always be used when the machine is operated on unsafe ground.**
7. **Drive slowly in sharp bends.**
8. **Avoid driving across slopes. Drive straight up or straight down the slope.**
9. **When driving close to edges, ditches or holes, make sure that at least 2/3 of the drum width is on previously compacted material (solid surface).**
10. **Make sure that there are no obstacles in the direction of travel, on the ground, in front of or behind the roller, or overhead.**
11. **Drive particularly carefully on uneven ground.**
12. **Use the safety equipment provided. The seat belt must be worn on machines fitted with ROPS/ROPS-cab.**
13. **Keep the roller clean. Clean any dirt or grease that accumulates on the operator platform immediately. Keep all signs and decals clean and legible.**
14. **Safety measures before refueling:**
 - Stop the engine
 - Do not smoke.
 - No naked flames in the vicinity of the roller.
 - Earth the filling equipment nozzle to the tank opening to avoid sparks.
15. **Before repairs or service:**
 - Chock the drums/wheels and under the strike-off blade.
 - Lock the articulation if necessary

Safety - General instructions

16. **Hearing protection is recommended if the noise level exceeds 85 dB(A). The noise level can vary depending on the equipment on the machine and the surface the machine is being used on.**
17. **Do not make any changes or modifications to the roller that could affect safety. Changes are only to be made after written approval has been given by Mauldin.**
18. **Avoid using the roller before the hydraulic fluid has reached its normal working temperature. Braking distances can be longer than normal when the fluid is cold. See instructions in the STOP section.**
19. **For your own protection always wear:**
 - helmet
 - working boots with steel toecaps
 - ear protectors
 - reflecting clothing/high visibility jacket
 - working gloves

Safety - when operating



Prevent persons from entering or remaining in the danger area, i.e. a distance of at least 7 m (23 ft) in all directions from operating machines. The operator may allow a person to remain in the danger area, but should then observe caution and operate the machine only when the person is visible or has given clear indications of where he or she is.

Slopes

This angle has been measured on a hard, flat surface with the machine stationary.

The steering angle was zero, the vibration was switched off and all tanks were full.

Always take into consideration that loose ground, steering the machine, vibration on, machine speed across the ground and raising the center of gravity can all cause the machine to topple at smaller slope angles than those specified here.

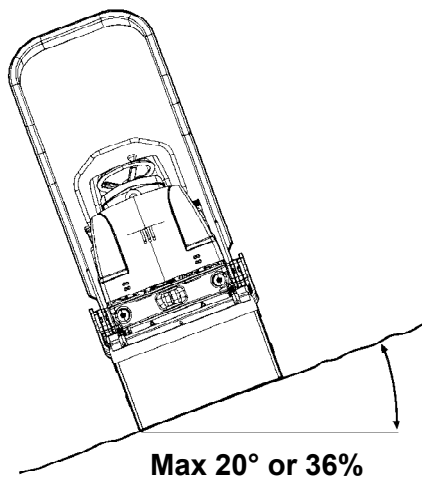

Fig. Operating on slopes



It is recommended that the ROPS (Roll Over Protective Structure) is always used when driving on slopes or unsafe ground.



Where possible, avoid driving across slopes. Drive instead straight up and down sloping ground.

Driving near edges

When driving near an edge, minimum 2/3 of the drum width must be on solid ground.



Keep in mind that the machine's center of gravity moves outwards when steering. For example, the center of gravity moves to the right when you steer to the left.

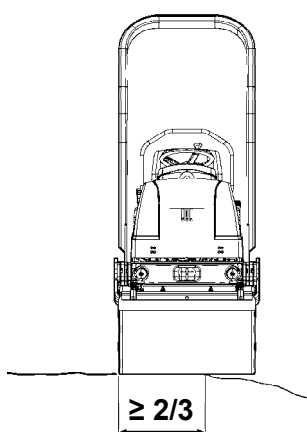

Fig. Position of drum when driving near an edge

Sitting position

Remain seated at all times when operating the roller.

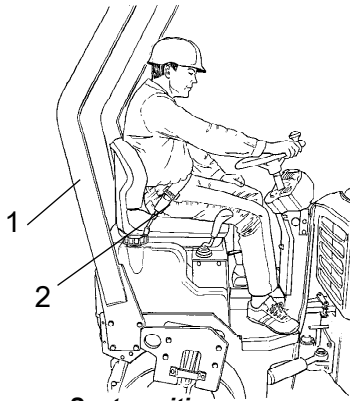



Figure. Seat position
1. ROPS
2. Seat belt

 **Always use the seat belt where fitted. Where the seat belt is not used, there is a great risk that the operator will be thrown off and land under the machine if the machine topples over.**

The seat belt is standard equipment on rollers fitted with Roll Over Protective Structure (ROPS) (1).

 **ROPS should always be in the raised position when machines with foldable ROPS are operated**

Special instructions

Standard lubricants and other recommended oils and fluids

Before leaving the factory, the systems and components are filled with the oils and fluids specified in the lubricant specification. These are suitable for ambient temperatures in the range -15°C to +40°C (5°F - 105°F).

Higher ambient temperatures, above +40°C (104°F)

For operation of the machine at higher ambient temperatures, although maximum +50°C (122°F), the following recommendations apply:

The petrol engine can be run at this temperature using normal oil. However, the following fluids must be used for other components:

Hydraulic system - mineral oil Shell Tellus T100 or equivalent.

Lower ambient temperature - Freeze risk

Make sure that the watering system is empty/drained of water (sprinkler, hoses, tank/s) or that anti-freeze has been added, to prevent the system freezing.

Temperatures

The temperature limits apply to standard versions of rollers.

High pressure cleaning

Do not spray water directly onto electrical components or the instrument panels.

Place a plastic bag over the fuel filler cap and secure with a rubber band. This is to avoid high pressure water entering the vent hole in the filler cap. This could cause malfunctions, such as the blocking of filters.



Never aim the water jet directly at the fuel tank cap. This is particularly important when using a high-pressure cleaner.

Fire fighting

If the machine catches fire, use an ABC-class powder fire extinguisher.

A BE-class carbon dioxide fire extinguisher can also be used.

Roll Over Protective Structure (ROPS)



Never carry out any welding or drilling operations of any kind on the Roll Over Protective Structure (ROPS).



Never attempt to repair a damaged ROPS structure. This must be replaced with new ROPS structure.

Battery handling



When removing batteries, always disconnect the negative cable first.



When fitting batteries, always connect the positive cable first.



Dispose of old batteries in an environmentally friendly way. Batteries contain toxic lead.



Do not use a quick-charger for charging the battery. This may shorten battery life.

Jump starting

⚠ Do not connect the negative cable to the negative terminal on the dead battery. A spark can ignite the oxy-hydrogen gas formed around the battery.

⚠ Check that the battery used for jump starting has the same voltage as the dead battery.

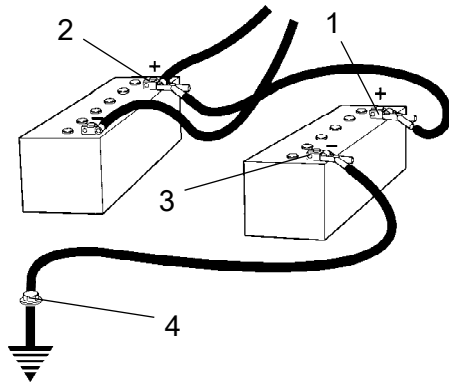

Fig. Jump starting

Turn the ignition and all power consuming equipment off. Switch off the engine on the machine which is providing jump start power.

First connect the jump start battery's positive terminal (1) to the flat battery's positive terminal (2). Then connect the jump start battery's negative terminal (3) to, for example, a bolt (4) or the lifting eye on the machine with the flat battery.

Start the engine on the power providing machine. Let it run for a while. Now try to start the other machine. Disconnect the cables in the reverse order.

Technical specifications - Noise/Vibrations/Electrical

Vibrations - Operator station (ISO 2631)

The vibration levels are measured in accordance with the operational cycle described in EU directive 2000/14/EC on machines equipped for the EU market, with vibration switched on, on soft polymer material and with the operator's seat in the transport position.

Measured whole-body vibrations are below the action value of 0.5 m/s² as specified in Directive 2002/44/EC. (Limit is 1.15 m/s²)

Measured hand/arm vibrations also were below the action level of 2.5 m/s² specified in the same directive. (Limit is 5 m/s²)

Noise level

The noise level is measured in accordance with the operational cycle described in EU directive 2000/14/EC on machines equipped for the EU market, on soft polymer material with vibration switched on and the operator's seat in the transport position.

Guaranteed sound power level, L_{wA} 102 dB (A)

Sound pressure level at the operator's ear (platform), L_{pA} 84 ±3 dB (A)

During operation the above values may differ because of the actual operational conditions.

Technical specifications - Dimensions

Dimensions, side view

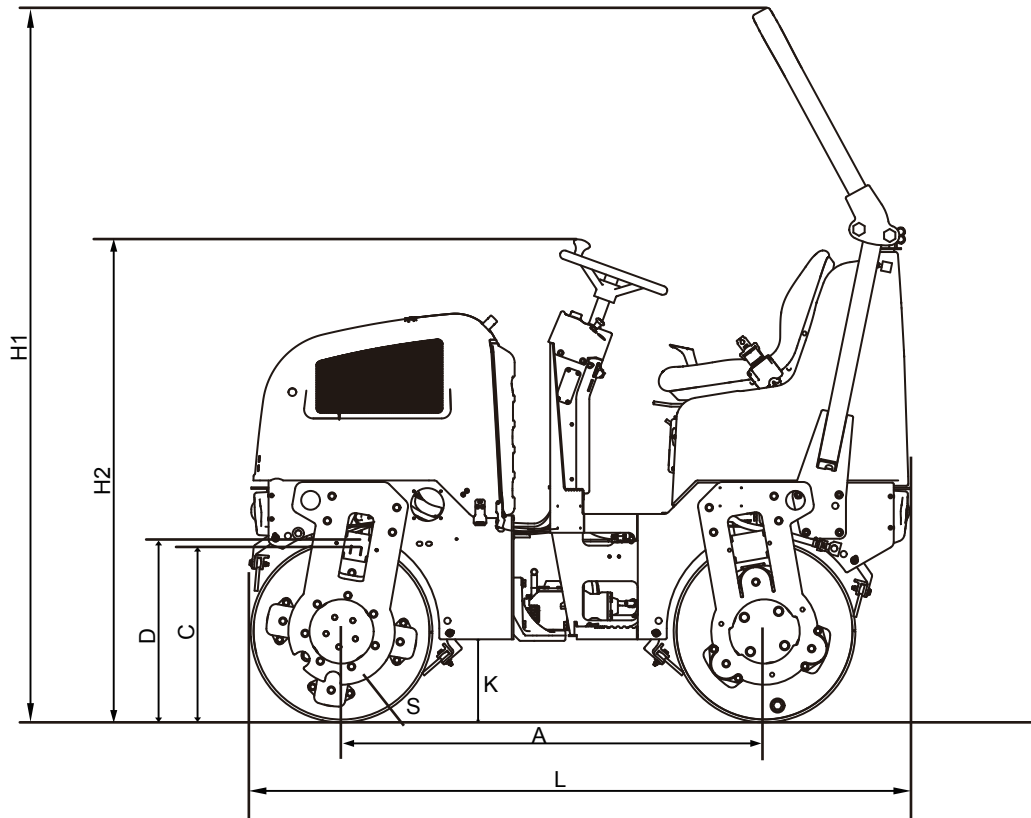

	Dimensions	mm	in
A	Wheelbase	1350	53,1
D	Drum diameter	584	23,0
H ₁	Height, with ROPS	2300	90,5
H ₂	Height, w/o ROPS	1585	62,4
K ₁		455	17,9
K ₂	Ground clearance	261	10,3
L ₂	Length	2107	83,0
S	Drum shell thickness	13	0,51

Technical specifications - Dimensions

Dimensions, top view

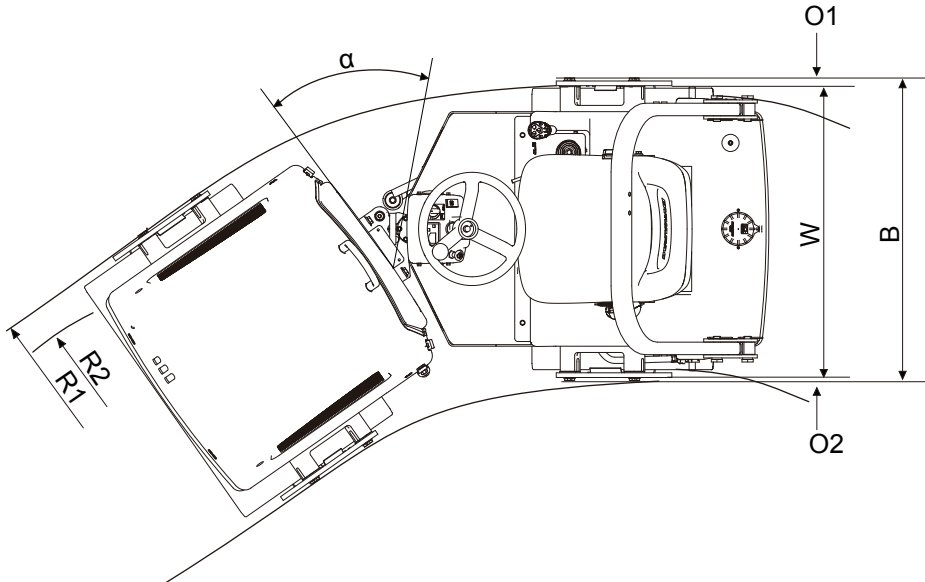

	Dimensions	mm	in
B	Width	970	38,2
O	Overhang	35	1,38
R_1	Turning radius, outside	2700	106,3
R_2		2660	104,7
W	Drum shell thickness	900	35,4
α	Steering angle	$\pm 34^\circ$	$\pm 34^\circ$

Technical specifications - Dimensions

Weights and volumes

Weights (s/n 003469 - 005137)

Service weight with ROPS (EN500)	1335 kg	2943 lbs
----------------------------------	---------	----------

Weights (Improved Frame, s/n 005138 -)

Operating mass (EN500)	1250 kg	2767 lbs
------------------------	---------	----------

Fluid volumes

Fuel tank	23 liters	6,0 gal
Water tank	175 liters/tank	46,2 gal

Working capacity

Compaction data (s/n 003469 - 005137)

Static linear load, front	6,6 kg/cm	37 pli
Static linear load, rear	8,2 kg/cm	45,9 pli
Amplitude	0,4 mm	0,016 in
Vibration frequency	70 Hz	4200 rpm
Centrifugal force	17 kN	3820 lb

Compaction data (Improved Frame, s/n 005138 -)

Static linear load, front	6 kg/cm	33,6 pli
Static linear load, rear	7,8 kg/cm	43,7 pli
Amplitude	0,4 mm	0,016 in
Vibration frequency	70 Hz	4200 rpm
Centrifugal force	16,7 kN	3752 lb

Note: The frequency is measured at high revs. The amplitude is measured as the real value and not the nominal.

Propulsion

Speed range	0-8	kph	0-5	mph
Climbing capacity (theoretical)	35	%		

Technical specifications - Dimensions

General

Engine

Manufacturer/Model	Honda GX630
Output at 3,600 rpm (SAE J1349)	15,5 kW / 21 Hp

Electrical system

Battery	12V 60Ah
Charging coil	12V 20A
Fuses	See the Electrical system section - fuses

Hydraulic system

Opening pressure	MPa	Psi
Drive system	27,0	3915
Supply system	2,0	290
Vibration system	22,0	3190
Control systems	7,0	1015
Brake disengagement	2,0	290

Tightening torque

Tightening torque in Nm for oiled, bright galvanized bolts tightened using a torque wrench.

STRENGTH CLASS

M - thread	8.8	10.9	12.9
M6	8,4	12	14,6
M8	21	28	34
M10	40	56	68
M12	70	98	117
M16	169	240	290
M20	330	470	560
M24	570	800	960
M30	1130	1580	1900
M36	1960	2800	-

Technical specifications - Dimensions

ROPS - bolts

Bolt dimensions :	M12 (PN 508063)
Strength class :	8.8
Tightening torque :	70 Nm



ROPS-bolts which are to be torque tightened must be dry.

Identification

Machine plate

The machine plate (1) is attached to the front left side of the rear frame, beside the steering joint.

The plate specifies the manufacturers name and address, the type of machine, the PIN, Product Identification Number (serial number), operating weight, engine power and year of manufacture. CE markings and the year of manufacture may be omitted on machines supplied to markets outside the EU.

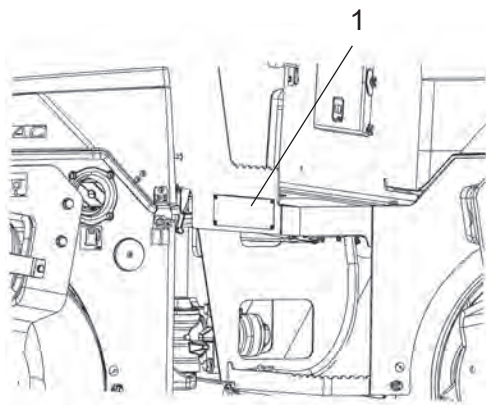



Fig. Operator's platform, left side
1. Machine plate

				Calder Brothers Corporation 450 E Warehouse Ct, Taylors, SC 29687			
Product Identification Number							
Designation	Type	Rated Power	Max axle load front / rear				
ROLLER	3500_G	14.2 kW	555/800 kg				
Gross machinery mass		Operating mass		Max ballast			
1300 kg		1250 kg		--- kg			
Made in China <small>4812 120001</small>							

Please state the machine's PIN when ordering spares.

Technical specifications - Dimensions

Product identification number on the frame

The machine PIN (Product Identification Number) (1) is punched on the right edge of the front frame.

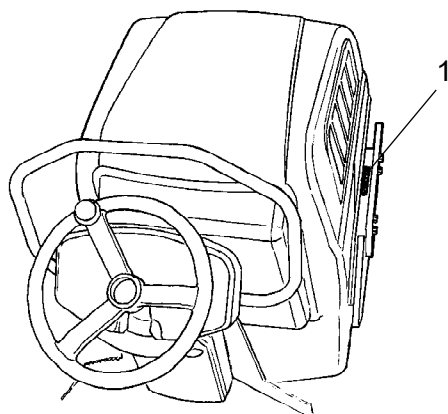

Fig. PIN Front frame

Technical specifications - Dimensions

Engine plates

The engine serial number (1) is punched below the starter.

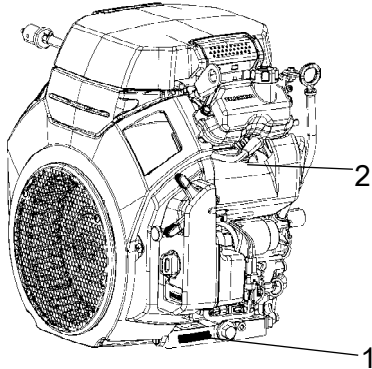
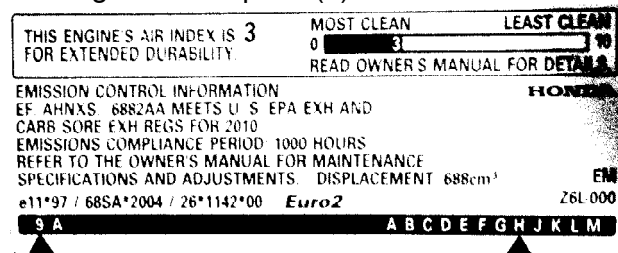

Figure. Engine
1. Serial number
2. EPA plate (USA)

Please specify the engine serial number when ordering spares. Refer also to the engine manual.

The engine's EPA plate (2).



Machine description- Decals

Location - decals

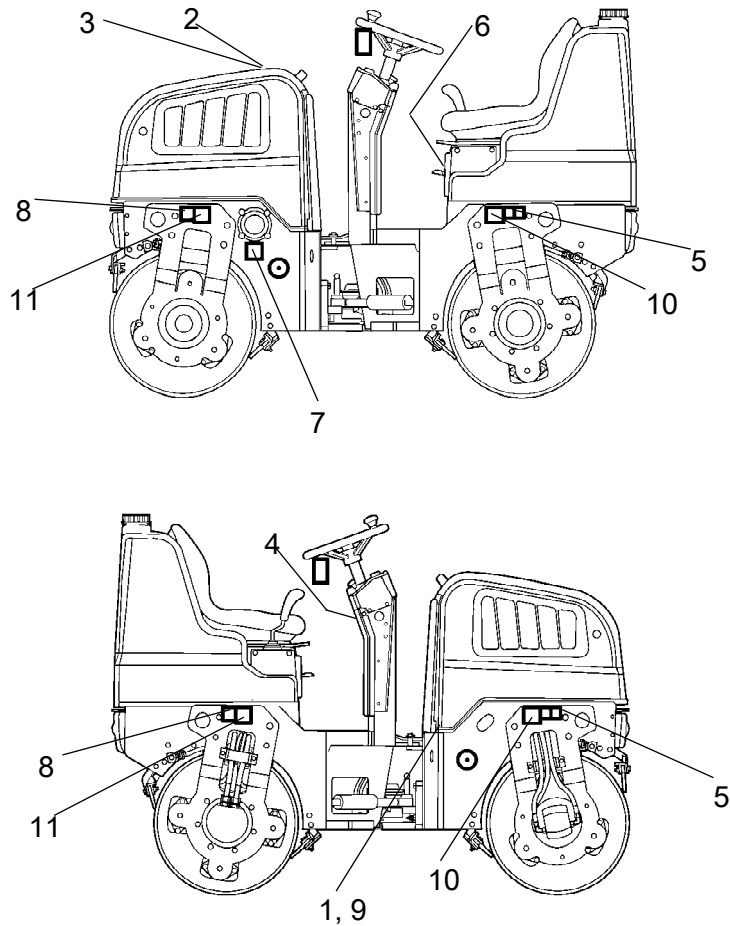
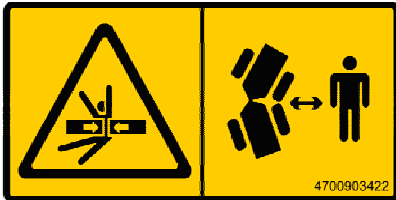

Fig. Location, decals and signs

1.	Warning, Crush zone	4700903422	8.	Lifting point	4700357587
2.	Warning, Rotating engine components	4700903423	9.	Hydraulic fluid level	4700272373
3.	Warning, Hot surfaces	4700903424	10.	Hoisting plate	4700904870
4.	Warning, Instruction manual	4700903459	11.	Fixing point	4700382751
5.	Warning, Locking	4700908229			
6.	Handbook compartment	4700903425			
7.	Petrol fuel	4700381371			

Safety decals

Always make sure that all safety decals are completely legible, and remove dirt or order new decals if they have become illegible. Use the part number specified on each decal.



4700903422

Warning - Crush zone, articulation/drum.

Maintain a safe distance from the crush zone.

(Two crush zones on machines fitted with pivotal steering)

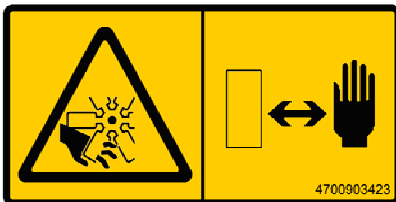

4700903423

Warning - Rotating engine components.

Keep your hands at a safe distance.

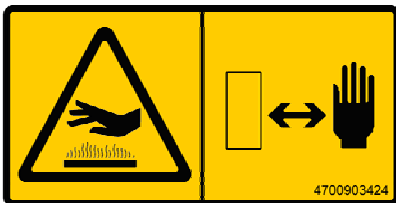

4700903424

Warning - Hot surfaces in the engine compartment.

Keep your hands at a safe distance.



4700903459

Warning - Instruction manual

The operator must read the safety, operation and maintenance instructions before operating the machine.



4700908229

Warning - Risk of crushing

The articulation must be locked when lifting.

Read the instruction manual.

Info decals

Handbook compartment

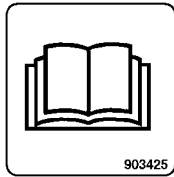

Petrol



Lifting point

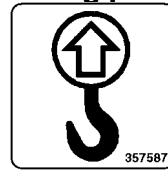

Hydraulic oil level

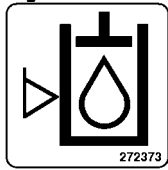

Hoisting plate

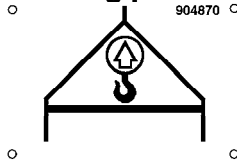

Securing point

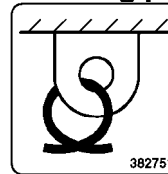

Instruments/Controls

Locations - Instruments and controls

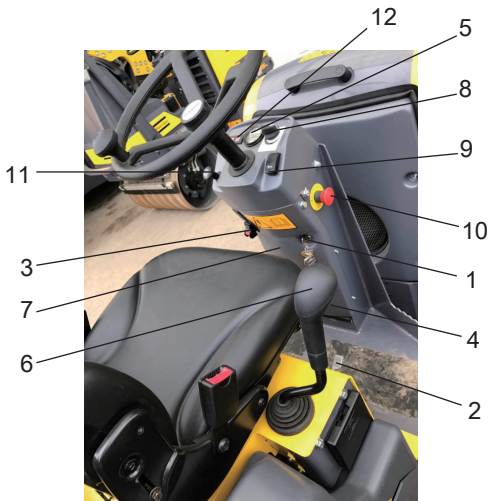



- | | |
|--|--------------------|
| 1. Ignition key | 7. Fuse box |
| 2. Control, engine speed | 8. Sprinkler |
| 3. Parking brake | 9. Horn |
| 4. Vibration on/off, switch | 10. Emergency stop |
| 5. Fuel level, hour meter | 11. Choke |
| 6. Forward/reverse lever | |
| 12. Parking brake warning lamp, Hydraulic oil temperature (not in use) | |



Fig. Instruments and control panel

Function description

No	Designation	Symbol	Function
1.	Starter switch		<p>The electric circuit is broken.</p> <p>All instruments and electrical controls are supplied with power</p> <p>Starter motor activation.</p>
2.	Control, engine speed		<p>Pull the lever up to obtain working speed. Move the lever down to obtain idling speed.</p>
3.	Parking brake		<p>The parking brake is activated if pressed when the machine is stationary. The brakes are released when pulled out.</p>
4.	Vibration On/Off. Switch		<p>When the switch for vibrations in the forward/reverse lever is pressed and released, the vibrations are engaged. Press the switch again to disengage the vibrations.</p>
5.	Fuel level, hour meter		
6.	Forward/Reverse lever		<p>The lever must be in neutral to start the petrol engine. The engine cannot be started if the forward/reverse lever is in any other position.</p> <p>The forward/reverse lever controls both the roller's driving direction and speed. When the lever is moved forward, the roller moves forward etc.</p> <p>The roller's speed is proportional to the distance the lever is from the neutral position. The further the lever is from the neutral position, the higher the speed.</p>
7.	Fuse box (on control column)		<p>Contains fuses for the electrical system. See under the heading 'Electrical system' for a description of fuse functions.</p>
8.	Sprinkler, control		<p>Turn the knob clockwise to switch on the water flow to the drum.</p>
9.	Horn, switch		<p>Press to sound the horn.</p>
10.	Emergency stop		<p>Brakes the roller and switches off the engine. The power supply goes off.</p> <p>NOTE: The emergency stop must be deactivated when starting the machine.</p>
11.	Choke		<p>Used in the pulled out position if necessary when the engine is started.</p>
12.	Parking brake warning lamp, Hydraulic oil temperature		

Electrical system

Relays and fuses on the machine

The figure shows the positions of the various fuses and relays. The table below gives their amperage and function. All fuses are flat pin fuses.

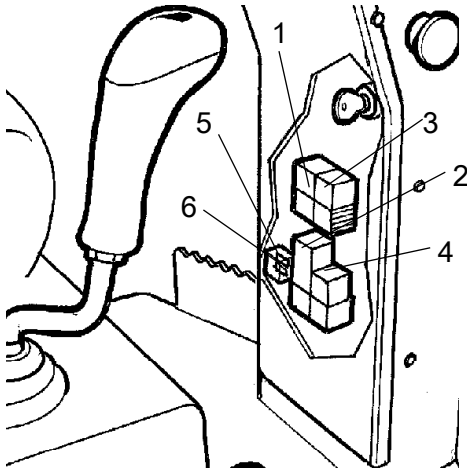

Relays		
1.	K1	Starting 12V 30A
2.	K2	Start, vibration, brake 12V 15A
3.	K22	Cooling fan, hydraulic system (Option) 12V 30A
4.	K20	Drive restriction relay 12V 10A

Fuses		
5.	7.5A	Start/stop valve Fuel pump Restriction relay VBS relay Vibration
6.	15A	Horn Backup alarm Fan (Option)

Fig. Control column

Operation

Before starting

Operator's seat - Adjusting

Adjust the operator's seat so that the position is comfortable and so that the controls are within easy reach.

The seat can be adjusted lengthways (1).

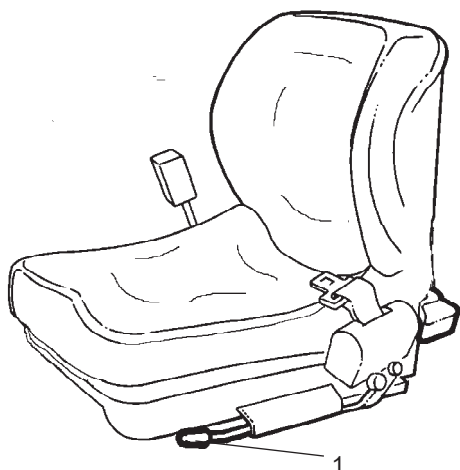

Fig. Operator's seat
1. Length adjustment

Sprinkler - Check



Make sure that the emergency stop knob is actually pressed in.



Figure. Instrument panel
1. Ignition key
3. Parking brake
8. Switch, sprinkler

Set the knob (8) for the sprinkler in the open position and check that the drums are watered.

Parking brake



Activate parking brake before leaving the machine.

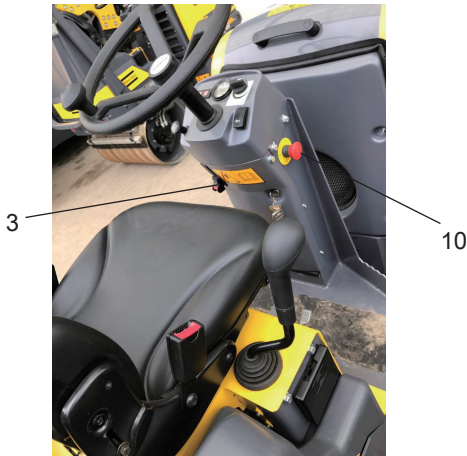

Figure. Control panel
3. Parking brake
10. Emergency stop

The machine starts with the parking brake deactivated.

Emergency stop

The machine starts with emergency stop pulled out.

Operator position



Replace the seat belt (1) if it shows signs of wear or has been subjected to high levels of force.



Never use the forward/reverse levers as a handle when mounting or disembarking from the roller.



Ensure that the anti-slip (3) on the platform is in good condition. Replace where anti-slip friction is poor.

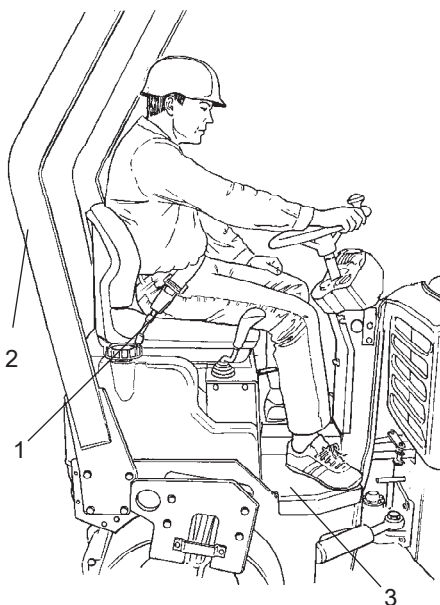

Fig. Operator's station
1. Seat belt
2. ROPS (Option)
3. Anti-slip

If a ROPS (Roll Over Protective Structure) (2) is fitted to the roller, always wear the seat belt (1) provided and wear a protective helmet.

Starting

Starting the engine

Make sure that the parking brake knob (3) is activated.

Sit down in the operator's seat and set the forward/reverse lever (6) in neutral. You cannot start the petrol engine with the lever in any other position.

Set the RPM control (2) to idle.

For cold start: Pull out the choke (11) and turn the ignition key to position II. Check that the warning lamps on the control panel are working. Turn the ignition key (1) to the right. As soon as the engine has started, release the ignition key.



Do not run the starter motor for too long. If the engine does not start immediately, wait a minute or so before trying again.

Warm up the engine at idling speed for a few minutes, although longer if ambient temperature is below +10 C (50 F)

When the engine is warm, check that the parking brake warning lamp (12) is still lit.



When starting and driving a machine that is cold, remember that the hydraulic fluid is also cold and that braking distances can be longer than normal until the machine reaches the working temperature.



Ensure that there is good ventilation (air extraction) if the engine is run indoors. Risk of carbon monoxide poisoning.



Figure. Control panel

- 1. Starter switch
- 2. Speed control
- 3. Parking brake
- 6. Forward/Reverse lever
- 11. Choke



Fig. Instrument panel

- 12. Parking brake warning lamp

Carefully move the forward/reverse lever (6) forwards or backwards, depending on which direction of travel is required.

Speed increases as the lever is moved away from the neutral position.



The speed should always be controlled using the forward/reverse lever and never by changing the engine speed.



Test the function of the reserve brake by activating parking brake (3) while the roller is moving slowly forwards and backwards.

Check when operating that the warning lamps do not come on.

A hydraulic fluid cooler is recommended for warm ambient temperatures and long operating periods

Driving

Operating the roller



Under no circumstances is the machine to be operated from the ground. The operator must be seated inside the machine during all operation.

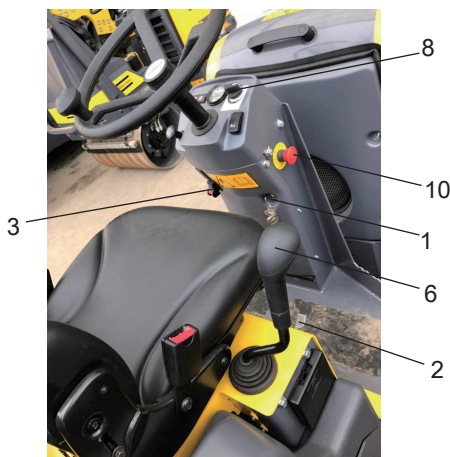

Figure. Instrument panel

1. Ignition key
2. Speed control
3. Parking brake
6. Forward/Reverse lever
8. Sprinkler knob
10. Emergency stop

Deactivate parking brake knob (3). Be prepared that the roller can move.

Check that the steering is working correctly by turning the steering wheel once to the right and once to the left while the roller is stationary.

When compacting asphalt, remember to turn on the sprinkler system (8).



Make sure that the area in front of and behind the roller is clear.

Vibration

Manual vibration - Switching on



Vibration should not be active when the roller is stationary. This can damage both the surface and the machine.

Engage and disengage vibration using the switch (4) on the underside of the forward/reverse lever.

Always switch off vibration before the roller comes to a standstill.



*Fig. Forward/Reverse lever
4. Switch, vibration On/Off*

Operating - Stopping

Braking

Normal braking



When starting and driving a machine that is cold, remember that the hydraulic fluid is also cold and that braking distances can be longer than normal until the machine reaches the working temperature.



Fig. Control panel

- 1. Key**
- 2. Engine speed control**
- 3. Parking brake**
- 4. Vibration On/Off**
- 6. Forward/reverse lever**

Press the switch (4) to switch off the vibration.

Move the forward/reverse lever (6) to the neutral position to stop the roller.

For shorter stopping periods, in which the operator needs to stand up with the engine running, it is important to check that the brake light is lit, including when stopping briefly on sloping ground.

Turn the engine speed control (2) back to idling and stop the engine. Switch off the machine using the key (1). Activate parking brake knob (3).

Reserve brake

Braking is normally activated using the forward/reverse lever. The hydrostatic transmission retards and slows the roller when the lever is moved towards the neutral position.

A disc brake in each drum motor acts as reserve brake when in motion and as a parking brake when stationary.



To brake in an emergency situation, press in the emergency stop (10), hold the steering wheel firmly and be prepared for a sudden stop.

After braking, return the forward/reverse lever to the neutral position and activate the parking brake.



Activate the parking brake (3) before leaving the machine.



Fig. Controls
3. Parking brake
10. Emergency stop

Switching off

Turn the starter switch (1) to the left to shut off position.



Fig. Instrument panel
1. Starter switch

Parking

Chocking the drums

 **Never disembark from the machine when the engine is running, unless the reserve/parking brake knob is depressed.**

 **Make sure that the roller is parked in a safe place with respect to other road users. Chock the drums if the roller is parked on sloping ground.**

 **Keep in mind that there is a risk of freezing during the winter. Drain the water tanks and water lines.**

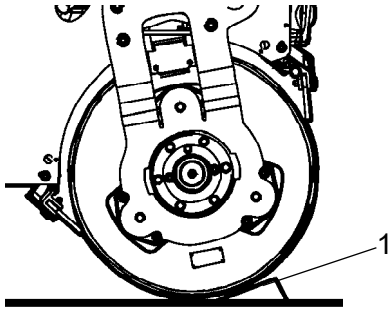

Fig. Set-up
1. Chocks

Long-term parking

 The following instructions should be followed when long term parking (more than one month).

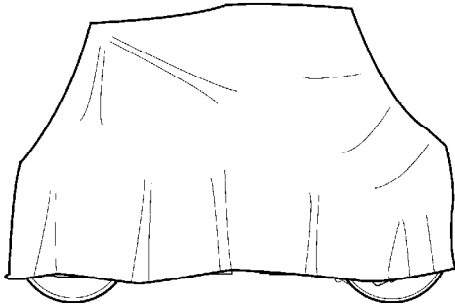

Fig. Roller weather protection

These measures apply when parking for a period of up to 6 months.

Before re-commissioning the roller, the points marked with an asterisk * must be returned to the pre-storage state.

Wash the machine and touch up the paint finish to avoid rusting.

Treat exposed parts with anti-rust agent, lubricate the machine thoroughly and apply grease to unpainted surfaces.

Engine

* Refer to the manufacturer's instructions in the engine manual that is supplied with the roller.

Battery

* Remove the battery from the machine, clean, grease the cable connectors (terminals) and trickle charge the battery once a month. The battery is otherwise maintenance free.

Air cleaner, exhaust pipe

* Cover the air cleaner (see under the heading 'Every 50 hours of operation' or 'Every 300 hours of operation') or its opening with plastic or tape. Also cover the exhaust pipe opening. This is to avoid moisture entering the engine.

Sprinkler system

* Empty the water tank and all hoses of all water (see under the heading "Every 2000 hours of operation").

Fuel tank

Fill the fuel tank completely full to prevent condensation.

Hydraulic reservoir

Fill the hydraulic reservoir to the uppermost level mark (see under the heading 'Every 10 hours of operation.')

Steering cylinder, hinges, etc.

Grease the steering cylinder piston with conservation grease.

Grease the hinges on the doors to the engine compartment. Grease both ends of the forward/reverse control (bright parts) (see under the heading 'Every 500 hours of operation').

Hoods, tarpaulin

* Lower the instrument cover over the instrument panel.

* Cover the entire roller with a tarpaulin. A gap must be left between the tarpaulin and the ground.

* If possible, store the roller indoors and ideally in a building where the temperature is constant.

Miscellaneous

Locking the articulation

Turn the steering wheel to the straight ahead position.

Raise the locking arm (1) and turn 180 degrees downward. Ensure that the cotter pin (2) is guided into its lower position correctly for locking the articulation.

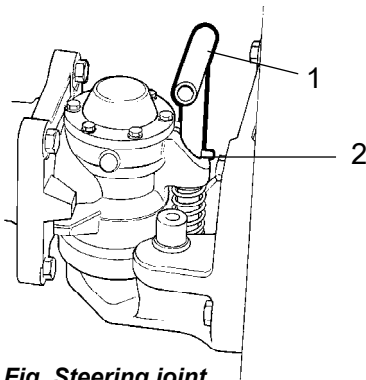

Fig. Steering joint
1. Locking arm
2. Cotter pin in locked position

Lifting the roller

! *The machine's gross weight is specified on the hoisting plate (1). Refer also to the Technical specifications.*

! Lifting gear such as chains, steel wires, straps, and lifting hooks must be dimensioned and used in accordance with the applicable safety regulations for lifting devices.

! *Stand well clear of the hoisted machine! Make sure that the lifting hooks are properly secured.*

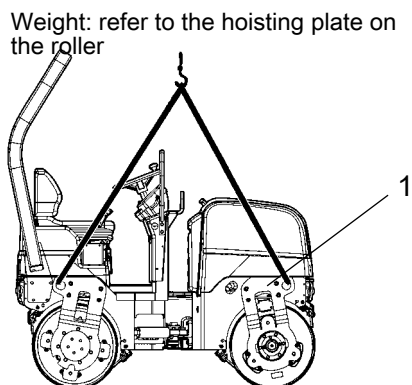

Fig. Roller prepared for lifting
1. Hoisting plate

Unlocking the articulation

! Remember to unlock the articulation before operating.

Raise the locking arm (1) and turn it 180 degrees upward. Check that the cotter pin (2) is guided correctly into position for unlocking the articulation.

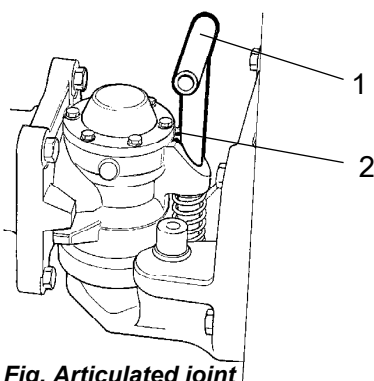
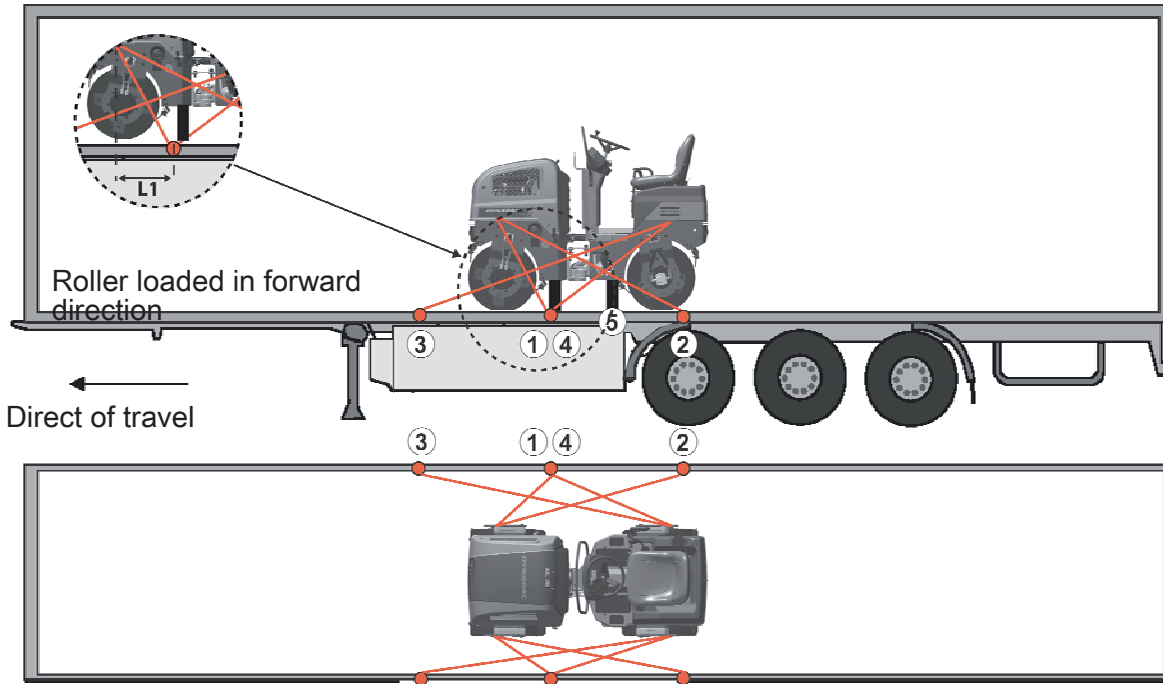

Fig. Articulated joint
1. Locking arm
2. Cotter pin in open position

Securing 3500_G for loading

Securing the 3500_G vibratory roller from Mauldin for transport.



- 1 - 2 = double lashings, i.e. one lashing with two parts secured to two different lashing mounts,
- 3 - 4 symmetrically located on the right and left sides.
- 5 = rubber

The lashings' permitted distance interval in meters		
(1 - 4: Double lashings, LC at least 1.7 tonnes (1700 daN), S _{TF} 300 kg (300daN))		
Double L ₁ - L ₂	Double L ₃ - L ₄	
0,6 - 3,0	0,1 - 3,0	

The distance L₁ above is between points D and E. D is the projected point directly at right angles laterally in relation to the edge of the platform from the lashing mount C on the roller. E is the lashing mount at the edge of the platform. L₂ - L₃ have a corresponding relationship.

Load carrier

- When loaded, the vibratory roller is centered laterally on the platform (± 5 cm).
- The parking brake is applied and in good working condition, and the articulated joint lock is closed.
- The drum is placed on a rubber liner, so that the static friction between the surfaces is at least 0.6.
- The contact surfaces must be clean, wet or dry, and free from frost, ice and snow.
- The lashing mounts on the load carrier have LC/MSL at least 2 tonnes.

Lashings

- The lashings comprise a lashing strap or chain with a permitted load (LC/MSL) of at least 1.7 tonnes (1,700 daN) and a pre-tension S_{TF} of at least 300 kg (300 daN). The lashings are re-tightened as required.
- Each of lashings 1-3 is either a double or two single lashings. A double lashing runs in a sling through a lashing point or around a machine part and down into two different mounts on the platform.
- Lashings in the same direction are placed in different lashing mounts on the trailer. Lashings that are pulled in opposite directions may be placed in the same lashing mount, however.
- The lashings are as short as possible.
- The lashing hooks must not lose grip if the lashings become slack.
- The lashings are protected against sharp edges and corners.
- The lashings are located symmetrically in pairs on the right and left sides.

Towing

The roller can be moved up to 300 meters (1,000 ft) using the instructions below.

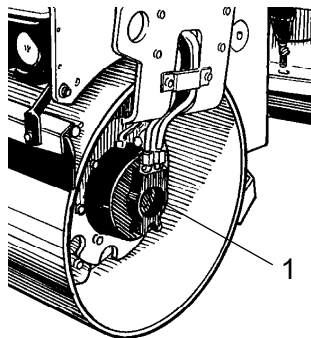

Fig. Drum
1. Propulsion motor, located left front and right rear.



Switch off the diesel engine and push in the emergency stop knob. Chock the drum to prevent the roller from moving when the brakes are disengaged.



The brakes in each propulsion motor must be mechanically released, as described below, before the roller is towed.

Releasing the brake

1. Remove the 2 plugs (191).

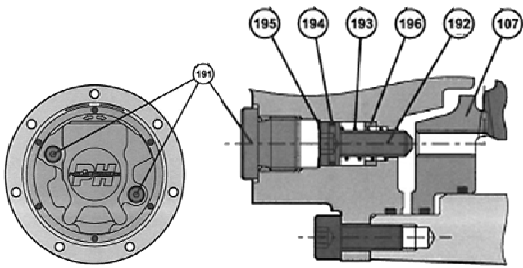
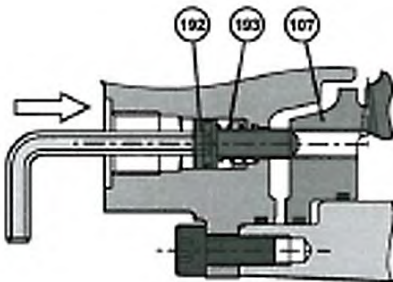

Figure. Releasing the brake



2. Press the screws (192) inwards to compress the springs (193) so that the screw reaches the brake (107) inner thread.

3. Tighten the two screws (192) alternately a little at a time so that the brake piston (107) loose (screw approximately 2 turns).



Tightening the screws (192) too hard can damage the inner mechanism



The machine should be started with reactivated brake.

Restored brake

Undo the two screws (192) alternately, and then insert the plugs (191).

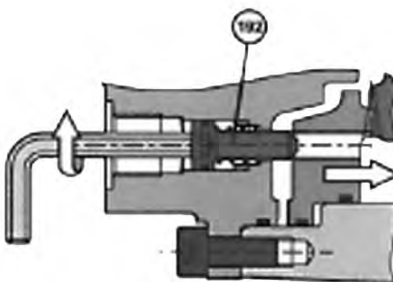

Tightening torque

Screws (192)

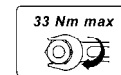

Plugs (191)

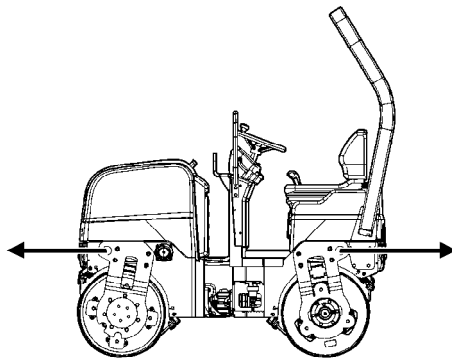
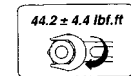

Fig. Towing the roller

Towing the roller



A towing bar must be used when towing, as the roller has no brakes and can only be slowed and stopped by the vehicle towing the roller.



The roller must be towed slowly, max. 3 km/h (2 mph) and for short distances only, max. 300 m (1000 ft).

When towing/recovering a machine, the towing device must be connected to both lifting holes. Pulling forces shall act longitudinally on the machine as illustrated. Max total towing force 50.8 kN (11,430 lbf), 25.4 kN (5,715 lbf) per fork.



Reset the steps taken for towing as described in the towing instructions on the previous page.

Operating instructions - Summary



1. **Follow the SAFETY INSTRUCTIONS specified in the Safety Manual.**
2. Make sure that all instructions in the MAINTENANCE section are followed.
3. Set the reserve/parking brake to its pulled-out position.
4. Move the forward/reverse lever to the NEUTRAL position.
5. Set the engine speed control to idle.
6. Start the engine and allow it to warm up.
7. Set the engine speed control to the operating position.



8. **Drive the roller. Operate the forward/reverse lever with care.**



9. **Test the brakes. Remember that the braking distance will be longer if the roller is cold.**

10. Use vibration only when the roller is in motion.
11. Check that the drums are thoroughly watered when watering is required.



12. **IN AN EMERGENCY:**
 - Press the **RESERVE/PARKING BRAKE BUTTON**
 - Hold the steering wheel firmly.
 - Brace yourself for a sudden stop.
13. Parking: - Switch off the machine and chock the drums.
14. When lifting: - Refer to the relevant section in the Instruction Manual.
15. When towing: - Refer to the relevant section in the Instruction Manual.
16. When transporting: - Refer to the relevant section in the Instruction Manual.
17. When recovering - Refer to the relevant section in the Instruction Manual.

Preventive maintenance

Complete maintenance is necessary for the machine to function satisfactorily and at the lowest possible cost.

The Maintenance section includes the periodic maintenance that must be carried out on the machine.

The recommended maintenance intervals assume that the machine is used in a normal environment and working conditions.

Acceptance and delivery inspection

The machine is tested and adjusted before it leaves the factory.

On arrival, before delivery to the customer, delivery inspection must be conducted as per the check list in the warranty document.

Any transport damage must be immediately reported to the transport company.

Warranty

The warranty is only valid if the stipulated delivery inspection and the separate service inspection have been completed as per the warranty document, and when the machine has been registered for starting under the warranty.

The warranty is not valid if damage has been caused by inadequate service, incorrect use of the machine, the use of lubricants and hydraulic fluids other than those specified in the manual, or if any other adjustments have been made without the requisite authorisation.

Maintenance - Lubricants and symbols



Always use high-quality lubricants and the amounts recommended. Too much grease or oil can cause overheating, resulting in rapid wear.

Fluid volumes

Drum	3,5 liters	3,7 qts
Ballast static drum *	65 liters	68,7 qts
Hydraulic reservoir	12 liters	3,2 gal
Petrol engine	1,5 liters without filter replacement	1,6 qts
	1,8 liters with filter replacement	1,9 qts

* In climates where there is a risk of freezing, see Coolant under the section Lubricants and Symbols.









Other fuel and lubricants are required when operating in areas with extremely high or extremely low ambient temperatures. See the 'Special instructions' chapter, or consult Mauldin.















Other fuel and lubricants are required when operating in areas with extremely high or extremely low ambient temperature. See the 'Special instructions' chapter, or consult Mauldin.

Maintenance - Lubricants and symbols

	ENGINE OIL	Air temperature -15°C - +50°C (5°F-122°F)	P/N 5580020624 (5 litres) P/N 5501522700 (20 litres)
	HYDRAULIC FLUID	Air temperature -15°C - +40°C (5°F-104°F)	P/N 9106230330 (20 litres) P/N 9106230331 (209 litres)
		Air temperature over +40°C (104°F)	Shell Tellus S2 V100
	BIOLOGICAL HYDRAULIC FLUID, PANOLIN	When it leaves the factory, the machine may be filled with biologically degradable fluid. The same type of fluid must be used when changing or topping up.	PANOLIN HLP Synth 46 (www.panolin.com)
	BIOLOGICAL HYDRAULIC FLUID	When it leaves the factory, the machine may be filled with biologically degradable fluid. The same type of fluid must be used when changing or topping up.	BP Biohyd SE-S46
	DRUM OIL	Air temp. -15°C - +40°C (5°F-104°F)	P/N 4812008274 (5 litres), P/N 4812008275 (20 litres)
		Air temp. 0°C (32°F) - above +40°C (104°F)	Shell Spirax AX 85W/140, API GL-5
	FUEL	See engine manual. To comply with emission requirements for Honda GX630 you must use fuel with a low or extremely low sulphur content.	-
			

Maintenance - Lubricants and symbols

Maintenance symbols

	Engine, oil level		Air filter
	Engine, oil filter		Battery
	Hydraulic reservoir, level		Sprinkler
	Hydraulic fluid, filter		Sprinkler water
	Drum, oil level		Recycling
	Lubricating oil		Fuel filter

Maintenance - Maintenance schedule

Service and maintenance points

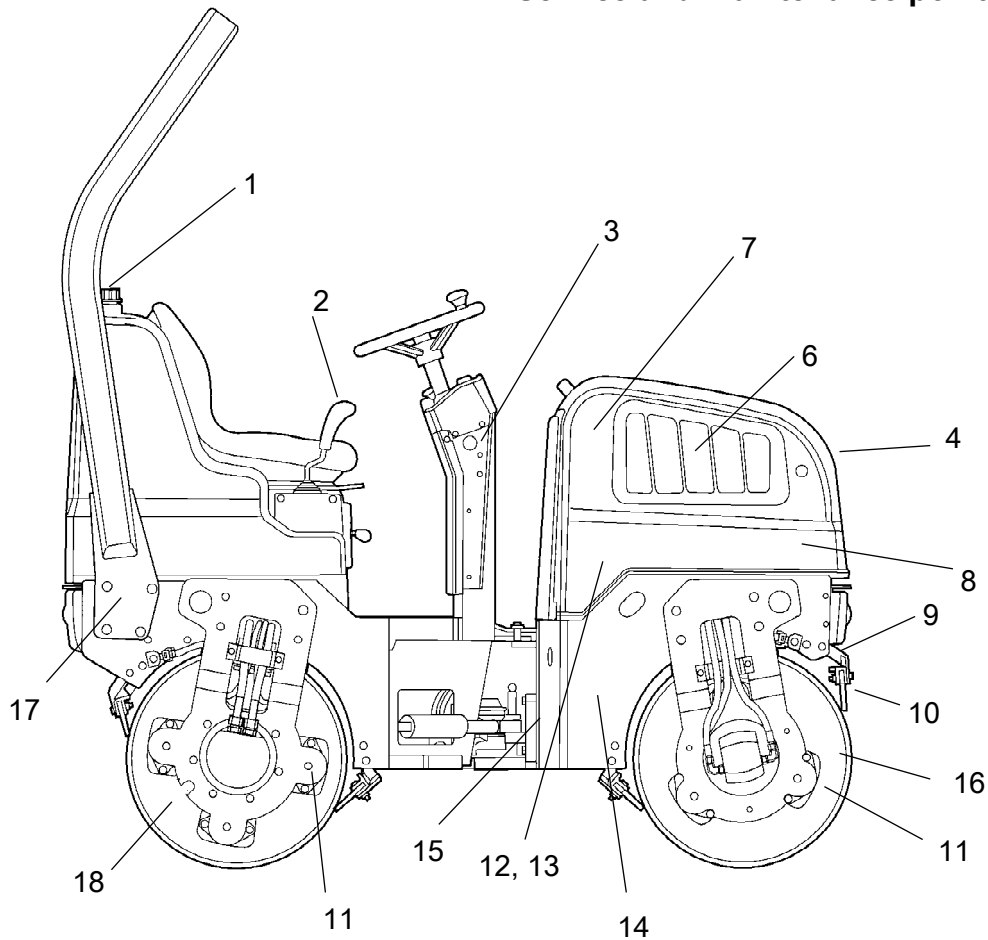

Fig. Service and maintenance points

- | | | |
|-------------------------------------|-------------------------------|--------------------------------------|
| 1. Water tank, filling | 7. Air cleaner | 13. Hydraulic fluid, filling |
| 2. Forward/Reverse lever | 8. Battery (maintenance free) | 14. Fuel tank, filling |
| 3. Reserve/parking brake | 9. Sprinkler | 15. Steering joint |
| 4. Hydraulic fluid cooler, (option) | 10. Scrapers | 16. Front drum, filling with oil |
| 6. Engine | 11. Rubber element | 17. ROPS, (option) |
| | 12. Hydraulic fluid filter | 18. Static drum, filling with water. |

Maintenance - Maintenance schedule

General

Periodic maintenance should be carried out after the number of hours specified. Use the daily, weekly etc. periods where number of hours cannot be used.



Remove all dirt before filling, when checking oils and fuel and when lubricating using oil or grease.



The manufacturer's instructions found in the engine manual also apply.



Where both operational hours and time intervals are specified, maintenance should be carried out at the point in time that occurs first.

Every 10 hours of operation (Daily)

Refer to the contents to find the page number of the sections referred to !

Pos. in fig	Action	Comment
	Before starting up for the first time on that day	
6	Check the oil level in the engine	Refer to the engine manual
13	Check the hydraulic reservoir level	
14	Refuel	
1	Fill the water tank	
9	Check the sprinkler system	
4	Check for free circulation of cooling air	
10	Check the scraper setting	
	Check the warning lamps	
7	Check the engine's air cleaner	Refer to the engine manual

After the first 20 hours of operation

Refer to the contents to find the page number of the sections referred to !

Pos. in fig	Action	Comment
6	Change the engine oil	Refer to the engine manual
6	Change the engine's oil filter	Refer to the engine manual

Maintenance - Maintenance schedule

After the FIRST 50 hours of operation

Refer to the contents to find the page number of the sections referred to !

	Action	Comment
12	Change the hydraulic fluid filter	

Every 50 hours of operation

Refer to the contents to find the page number of the sections referred to !

Pos. in fig	Action	Comment
3	Test the brakes	
7	Clean the air cleaner	Refer to the engine manual
11	Check the rubber elements and bolted joints	
18	Check and lubricate drum bearing seat	

Every 100 hours of operation

Refer to the contents to find the page number of the sections referred to !

Pos. in fig	Action	Comment
6	Check and adjust the spark plug	Refer to the engine manual

Maintenance - Maintenance schedule

Every 200 / 400 / 600 / 800 hours of operation

Refer to the contents to find the page number of the sections referred to !

Pos. in fig	Action	Comment
6	Replace the spark plugs	Refer to the engine manual.
6	Check idling revs	Refer to the engine manual.
6	Check valve play	Refer to the engine manual.
6	Replace the fuel filter	Refer to the engine manual.
6	Change the engine oil	Refer to the engine manual.
6	Change the oil filter	Refer to the engine manual.
	Check lubrication of controls and pivots	Lubricate as necessary
	Replace valve cover gasket	Refer to the engine manual.

Every 500 hours of operation

Refer to the contents to find the page number of the sections referred to !

Pos. in fig	Action	Comment
6	Clean the combustion chamber	Refer to the engine manual
16	Check the oil level in the front drum	
13	Check the hydraulic reservoir cover/breather	
15	Check the condition of the articulation	
7	Replace the air cleaner insert	Refer to the engine manual

Maintenance - Maintenance schedule

Every 1000 hours of operation

Refer to the contents to find the page number of the sections referred to !

Pos. in fig	Action	Comment
6	Replace the spark plugs	Refer to the engine manual.
6	Check idling revs	Refer to the engine manual.
6	Check valve play	Refer to the engine manual.
6	Replace the fuel filter	Refer to the engine manual.
4	Clean the hydraulic fluid cooler	Accessory
	Check lubrication of controls and pivots	Lubricate as necessary
	Replace valve cover gasket	Refer to the engine manual.
6	Clean the combustion chamber	Refer to the engine manual.
16	Check the oil level in the front drum	
13	Check the hydraulic reservoir cover/breather	
15	Check the condition of the articulation	
7	Replace the air cleaner insert	Refer to the engine manual.
12	Change the hydraulic fluid filter	
6	Change the engine oil	Refer to the engine manual.
6	Change the oil filter	Refer to the engine manual.

Maintenance - Maintenance schedule

Every 2000 hours of operation

Refer to the contents to find the page number of the sections referred to !

Pos. in fig	Action	Comment
6	Replace the spark plugs	Refer to the engine manual
6	Check idling revs	Refer to the engine manual
6	Check valve play	Refer to the engine manual
6	Replace the fuel filter	Refer to the engine manual
4	Clean the hydraulic fluid cooler	Accessory
	Check lubrication of controls and pivots	Lubricate as necessary
	Replace valve cover gasket	Refer to the engine manual
6	Clean the combustion chamber	Refer to the engine manual
13	Check the hydraulic reservoir cover/breather	
15	Check the condition of the articulation	
7	Replace the air cleaner insert	Refer to the engine manual
12	Change the hydraulic fluid filter	
6	Change the engine oil	Refer to the engine manual
6	Change the oil filter	Refer to the engine manual
13	Change the hydraulic fluid	
16	Change the oil in the front drum	
18	Change the water in the rear drum	
1	Drain and clean the water tank	
6	Drain and clean the fuel tank	Refer to the engine manual
6	Check the fuel line	Refer to the engine manual

Maintenance - Maintenance measures, before use



Park the roller on a level surface. When checking and making adjustments, the engine should be switched off and the emergency/parking brake should be applied, if not otherwise specified.

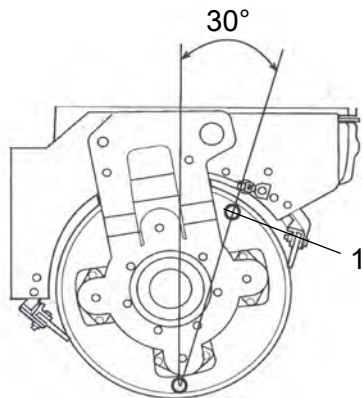

Fig. static drum
1. Water plug in position for filling.

Static drum - Filling with water



Unscrew the filler plug (1) and fill with pure water. The recommended volume of water in the drum is 65 liters. Where there is a risk of freezing, remember to add antifreeze.



Only additive: Environmentally-friendly antifreeze. Dosage according to the recommendations from the antifreeze supplier.

Maintenance, 10h

 **Park the roller on a level surface. When checking and making adjustments, the engine should be switched off and the emergency/parking brake should be applied, if not otherwise specified.**

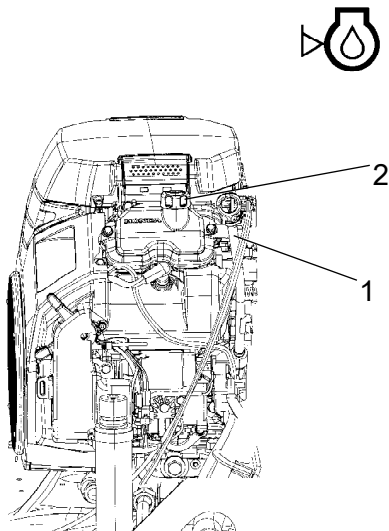



Fig. Engine
1. Dipstick
2. Filler plug

Engine - Checking the oil level

 **Ensure that the engine cover is fully open when work is carried out under the cover.**

Open the engine cover lock and lower the engine cover forwards.

Check the oil level using the dipstick (1). The level should be between the marks. If the level is near the lower mark, top off with fresh engine oil via the filler cap (2). See under the heading lubricants for the correct oil grade.

 **Never overfill with oil, as this can damage the engine.**



Hydraulic reservoir, Level check - Filling

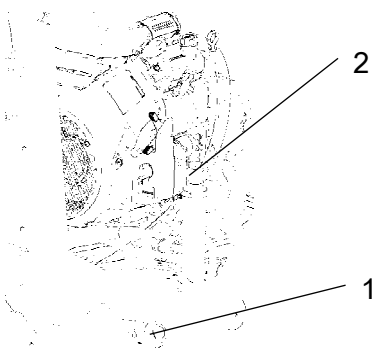

Fig. Hydraulic reservoir
1. Sight glass
2. Filler hose

Wipe the sight glass (1) clean. Make sure that the oil level is in the middle of the sight glass. If necessary, top up with fresh hydraulic fluid through the filler hose (2).

See under the heading 'Lubricants' for the correct fluid grade.



Refueling

Refuel the tank every day before starting work. Open the tank cap and fill through the filler pipe (1).



Never refuel while the engine is running. Do not smoke and avoid spilling fuel.



Stop the engine. Short-circuit (press) the filler gun against the filler pipe (1) while refuelling.

The tank holds 23 liters (31.7 gal) of fuel.

Water tank - Filling



Unscrew the tank cap (1), and fill with clean water.

Fill the water tank; it holds 175 liters.



Only additive: A small amount of environmentally friendly antifreeze.



Sprinkler system - Check, cleaning



Check that the holes in the sprinkler pipe (1) are not clogged, clean if necessary.

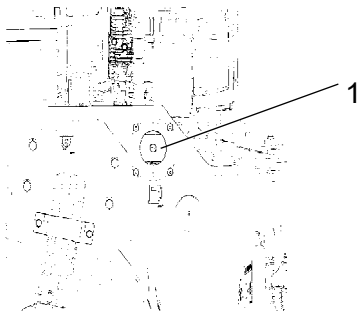

Fig. Left side
1. Filler pipe/cap

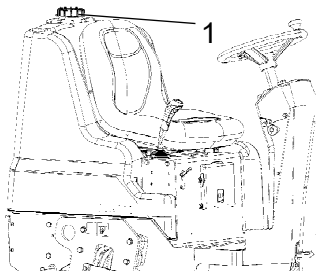

Fig. Water tank
1. Tank cap

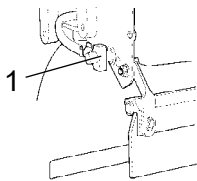

Fig. Sprinkler system
1. Sprinkler pipes with holes for water.

Air circulation - Check

Ensure that the petrol engine has free circulation of cooling air through the vents in the hood.

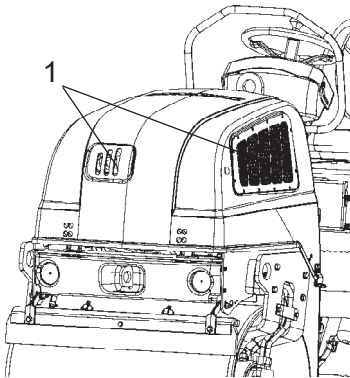

Fig. Engine cover
1. Cooling air grille/engine

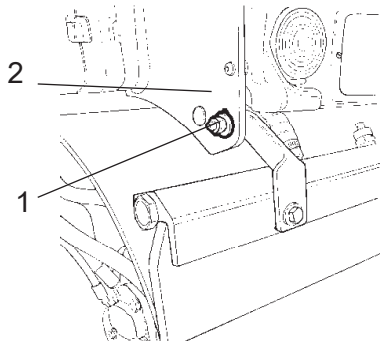

Fig. Front scrapers in transport position
1. Locking nut
2. Frame side

Scrapers - Check, adjustment

Make sure that the scrapers are undamaged. Adjust the scrapers if necessary in the following way:

For firmer application of the scraper, undo the locking nut (2) and turn it to the right until the desired application is achieved.

Lock this setting by tightening the locking nut against the frame side (2).

Adjust the pressure on both scraper brackets.

To set a lower scraper pressure, adjust in the reverse order to the above.

Warning lamps - Check

Check that the warning lamps (12).



Figure. Control panel.
3. Parking brake
12. Parking brake warning lamp

Air cleaner - check

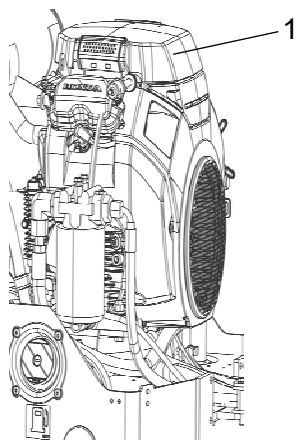

Check that hoses and couplings are not leaking and that the air cleaner cover is on properly.

Clean the air cleaner when operated in extremely dusty environments.

Fig. Engine
1. Air filter

Maintenance - 20h

 **Park the roller on a level surface. When checking and making adjustments, the engine should be switched off and the emergency/parking brake should be applied, if not otherwise specified.**

 **Check that the engine cover is fully open before carrying out work underneath it.**



Engine oil and oil filter - Change

Run the engine until it is warm before draining the oil.

 **Switch off the engine and push in the reserve/parking brake knob.**

 **Take great care when draining fluids and oils. Wear protective gloves and goggles.**

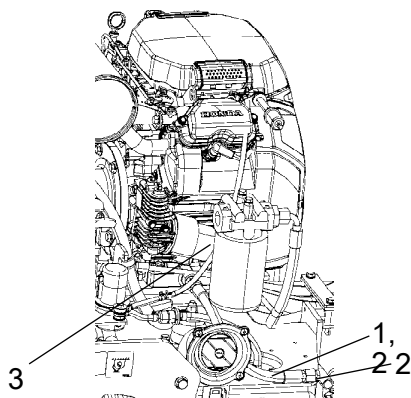



Fig. Engine compartment, left side

- 1. Drain hose
- 2. Plug
- 3. Oil filter

Place a receptacle that holds at least 4 liters (1 gal.) under the drain plug (2).

Undo the oil filler cap (4) and remove the plug (2) from the end of the drain hose (1); allow all the engine oil to run out.

 **Deliver the drained oil to special waste handling.**

 **Refer to the engine manual for detailed instructions when changing oil and filters.**

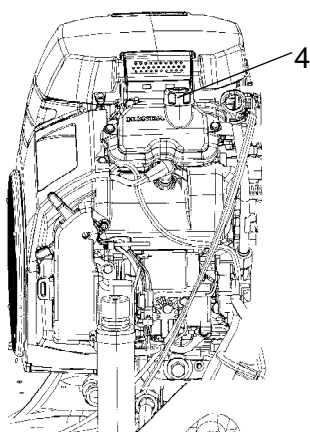

Fig. Engine compartment, right side
4. Filler cap

Remove the oil filter (3) and insert a new one.

Collect any spillage.

Fit the drain plug (2) to the end of the hose.

Fill with fresh engine oil (see under Lubricants heading for the correct oil grade), refit the filler cap (4) and check the level on the dipstick.

Start the engine and check the tightness around the oil filter.

Maintenance - 50h

 **Park the roller on a level surface. When checking and making adjustments, the engine should be switched off and the emergency/parking brake should be applied, if not otherwise specified.**

 **Check that the engine cover is fully open before carrying out work underneath it.**



Brakes - Check

 **Check the brakes by carrying out the following:**

Drive the roller slowly forwards.

Activate parking brake (3). The parking brake warning lamp (12) should light and the roller should stop.

After testing the brakes, set the forward/reverse lever in neutral.

Deactivate the parking brake (3).

The roller can now be started.

Refer also to the section in the manual on operation.



Figure. Control panel.
3. Parking brake
12. Parking brake warning lamp

Air cleaner - cleaning

Unclip the four lock catches (1) and lift the air cleaner's cover (2). Lift out the plastic foam and clean it in warm soapy water, rinse and dry.

Clean the air filter by tapping it with the palm of the hand or blow compressed air (not exceeding 207 kPa (2,1 kgf/cm², 30 psi)) through the filter element from the air cleaner case side. Brushing the filter may cause dust to penetrate the fibres. Replace the filter if it is very dirty.

Dry the inside of the filter container and its cover with a damp rag. Make sure that dirt does not enter the suction pipe.

Clean the air cleaner when operated in extremely dusty environments.

Refit the filter element and the cover and secure the cover with put the latch (1) to locked position.

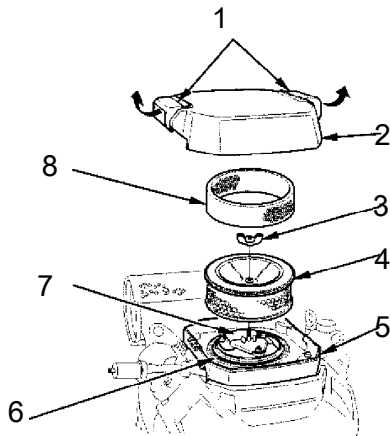

Fig. Air cleaner
 1. Cover latch
 2. Cover
 3. Wing nut
 4. Filter element
 5. Case
 6. Seal
 7. Air chamber
 8. Foam filter element

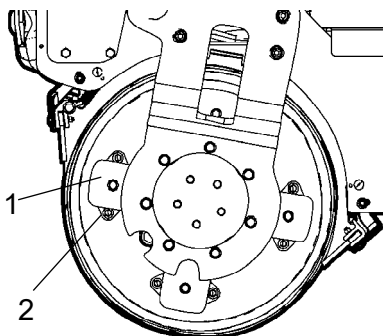

Figure. Drum suspension
 1. Rubber element
 2. Fastening screws

Rubber elements and fastening screws - Check

Check all the rubber elements (1), and replace all the elements if more than 20% of them on one side of the drum are cracked deeper than 10-15 mm.

Use a the blade of a knife or pointed object to check.

Check also that the screw fasteners (2) are tightened.



The screws on the rubber elements are sealed with Loctite. Check the rubber elements on both sides of the roller.

Drum bearing seat - Check and lubrication

Drum bearing seat, which located on the left side of the rear drum. Check the condition of the bearing seat, grease the bearing seat through the grease nipple (1).

Grease the bearing point with twenty to twenty-five strokes of hand-operated grease gun.

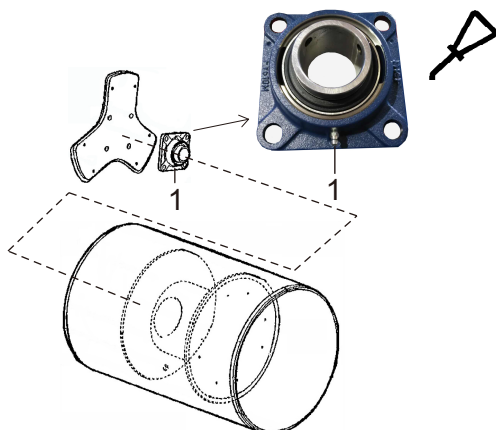

Figure. Drum bearing seat
 1. Grease nipple

Maintenance - 100h



Park the roller on a level surface. When checking and making adjustments, the engine should be switched off and the emergency/parking brake should be applied, if not otherwise specified.



Check that the engine cover is fully open before carrying out work underneath it.

Spark plug - Check and adjustment



Switch off the engine and push in the reserve/parking brake knob.



Observe care with hot surfaces. Wear gloves.

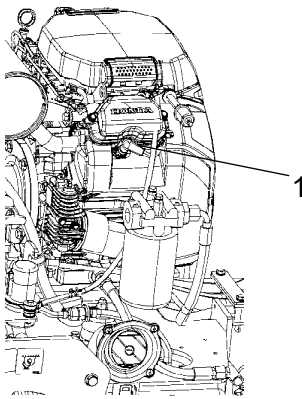

**Fig. Engine compartment left side
1. Spark plug**



Refer to the engine manual for detailed instructions.



Dispose of used spark plugs properly.

Maintenance - 200 / 400 / 600 / 800 h



Park the roller on a level surface. When checking and making adjustments, the engine should be switched off and the emergency/parking brake should be applied, if not otherwise specified.



Check that the engine cover is fully open before carrying out work underneath it.

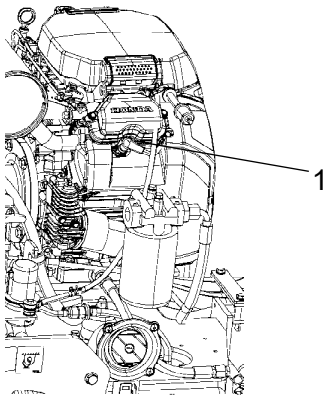

Fig. Engine compartment left side
1. Location of the spark plug on the left and right sides of the engine.

Spark plug - Replace



Switch off the engine and push in the reserve/parking brake knob.



Observe care with hot surfaces. Wear gloves.



Refer to the engine manual for detailed instructions.



Dispose of used spark plugs properly.



Engine's fuel filter - Check

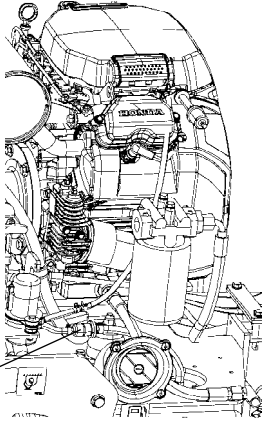

**Fig. Engine compartment left side
1. Fuel filter**



Switch off the engine and push in the reserve/parking brake knob.



Use caution. Wear gloves.

Replace the fuel filter (1).



Refer to the engine manual for detailed instructions.



Dispose of the old filter carefully.



Engine oil and oil filter - Change

Run the engine until it is warm before draining the oil.



Switch off the engine and push in the reserve/parking brake knob.



Take great care when draining fluids and oils. Wear protective gloves and goggles.

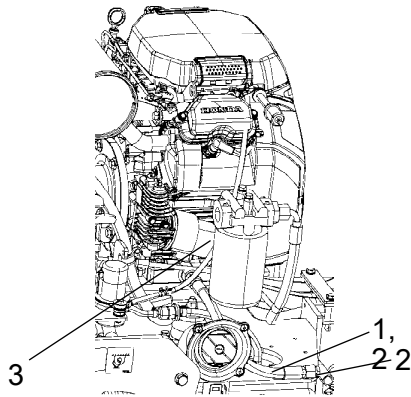

Fig. Engine compartment, left side

- 1. Drain hose
- 2. Plug
- 3. Oil filter

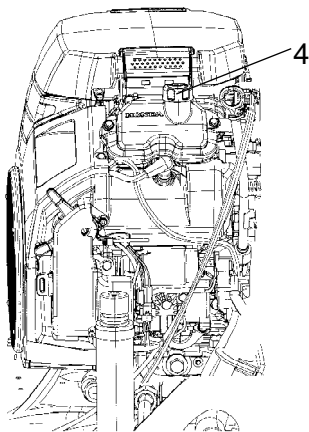

Fig. Engine compartment, right side
4. Filler cap

Place a receptacle that holds at least 4 liters (1 gal.) under the drain plug (2).

Undo the oil filler cap (4) and remove the plug (2) from the end of the drain hose (1); allow all the engine oil to run out.



Deliver the drained oil to special waste handling.



Refer to the engine manual for detailed instructions when changing oil and filters.

Remove the oil filter (3) and insert a new one.

Collect any spillage.

Fit the drain plug (2) to the end of the hose.

Fill with fresh engine oil (see under Lubricants heading for the correct oil grade), refit the filler cap (4) and check the level on the dipstick.

Start the engine and check the tightness around the oil filter.



Forward/Reverse controls and joints - Check and lubrication

Unscrew the protective plate. Check the friction on the forward/reverse lever. The friction nut (1) should be applied with sufficient pressure to keep the forward/reverse lever in the set position during operation.

If the lever gets stiff after prolonged use, lubricate the lever at the bearing bushings and at the cable with a few drops of oil at each place.

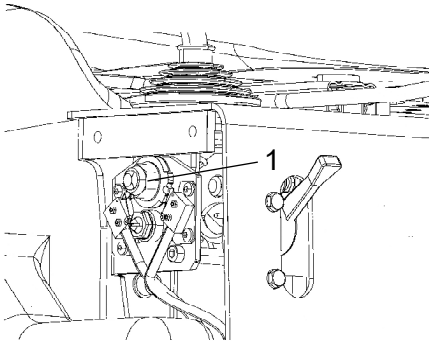

Figure. Forward/reverse lever
1. Friction nut

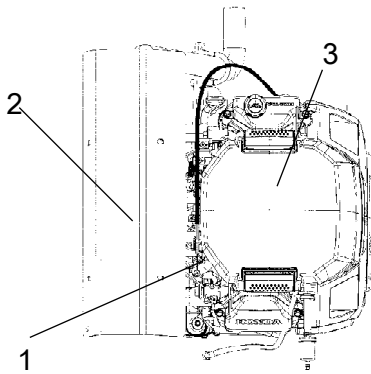



Fig. Engine compartment
1. F/R lever cable
2. Heat cover
3. Air filter

If the forward/reverse lever still is stiff after the above adjustments, lubricate the other end of the control cable with a few drops of oil. The cable is located on the top of the propulsion pump.

Maintenance - 500h

 **Park the roller on a level surface. When checking and making adjustments, the engine should be switched off and the emergency/parking brake should be applied, if not otherwise specified.**

 **Check that the engine cover is fully open before carrying out work underneath it.**



Front drum - Checking the oil level

Park the roller on a level surface, and drive the roller slowly until the oil plug (1) is in the middle of the semicircle shaped notch in the drum suspension.

 **Switch off the engine, disconnect the power and push in the reserve/parking brake knob.**

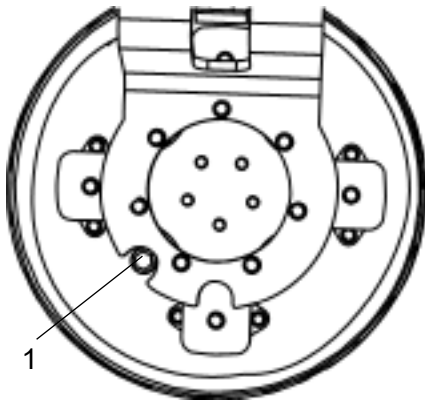

Figure. Front drum, drive side
1. Oil plug

Unscrew the plug and check that the oil level reaches the hole's lower edge. If necessary, top off with fresh transmission fluid. See under the heading lubricants for correct fluid grade.

Clean the magnetic oil plug (1) from any metallic residue, and refit the plug.



Hydraulic reservoir - Check/venting

Unscrew and make sure that the reservoir cap is not blocked. Air must have unobstructed passage through the cap in both directions.

If blocked in either direction, clean with a little diesel oil and blow with compressed air until unblocked or replace the cap with a new one.



Wear eye protectors and gloves when working with compressed air.

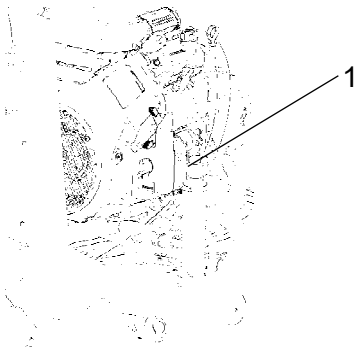

Figure. Engine compartment, right side
1. Hydraulic fluid tank cap

Steering joint - Check

Inspect the steering joint to detect any damage or cracks.

Check and tighten any loose bolts.

Check also for any stiffness and play in the steering joint. Rectify if necessary.

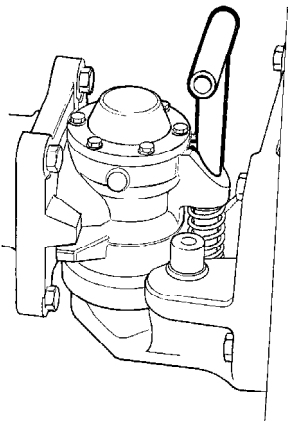

Fig. Steering joint

Air cleaner - replace insert

Pull the air cleaner cover latch (1) to the unlocked position and remove the cover (2).

Remove the wing nut (3) from the filter element (4).

Lift out the foam filter element (8) and the filter element (4).

Dry the inside of the filter container and its cover with a damp rag. Make sure that dirt does not enter the suction pipe.

Reinstall with new filter element and secure the cover with the latch (1) to locked position.

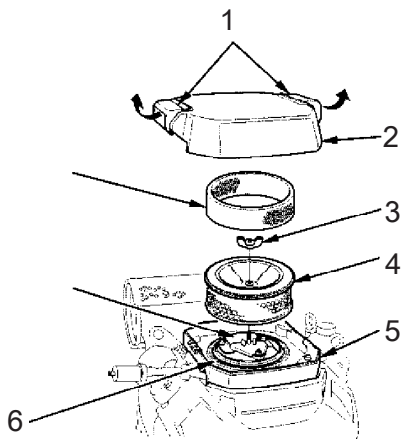

Fig. Air cleaner

1. Cover latch
2. Cover
3. Wing nut
4. Filter element
5. Case
6. Seal
7. Air chamber
8. Foam filter element

Maintenance - 1000h



Park the roller on a level surface. When checking and making adjustments, the engine should be switched off and the emergency/parking brake should be applied, if not otherwise specified.



Check that the engine cover is fully open before carrying out work underneath it.

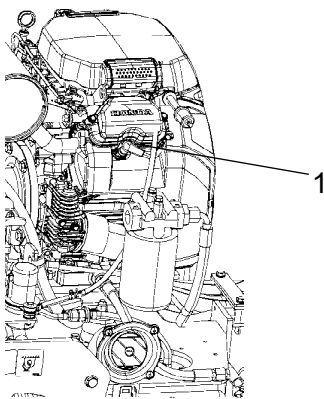

Fig. Engine compartment left side
1. Location of the spark plug on the left and right sides of the engine.

Spark plug - Replace



Switch off the engine and push in the reserve/parking brake knob.



Observe care with hot surfaces. Wear gloves.



Refer to the engine manual for detailed instructions.



Dispose of used spark plugs properly.



Engine's fuel filter - Replace

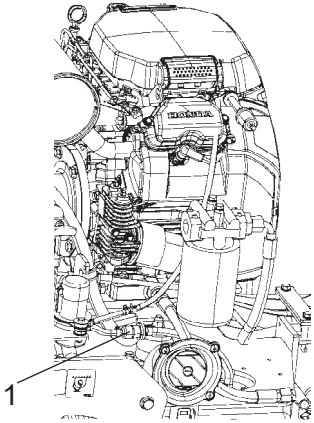

**Fig. Engine compartment left side
1. Fuel filter**



Switch off the engine and push in the reserve/parking brake knob.



Use caution. Wear gloves.

Replace the fuel filter (1).



Refer to the engine manual for detailed instructions.



Dispose of the old filter carefully.

Hydraulic fluid cooler - Cleaning (Option)

Clean the hydraulic fluid cooler's cooling flanges, ideally with compressed air. Blow the cooler clean by blowing air from the inside outwards.



Wear gloves and eye protectors when working with compressed air.



Forward/Reverse controls and joints - Check and lubrication

Unscrew the protective plate. Check the friction on the forward/reverse lever. The friction nut (1) should be applied with sufficient pressure to keep the forward/reverse lever in the set position during operation.

If the lever gets stiff after prolonged use, lubricate the lever at the bearing bushings and at the cable with a few drops of oil at each place.

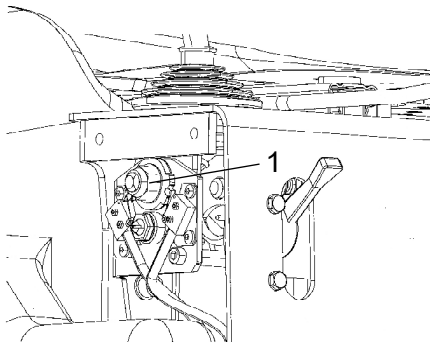

Figure. Forward/reverse lever
1. Friction nut

If the forward/reverse lever still is stiff after the above adjustments, lubricate the other end of the control cable with a few drops of oil. The cable is located on the top of the propulsion pump.

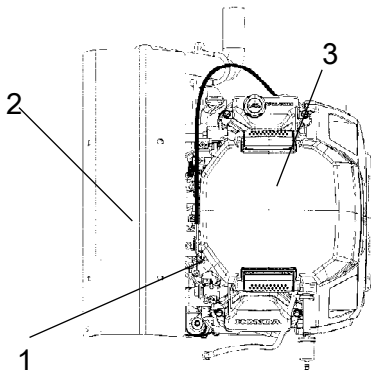

Fig. Engine compartment
1. F/R lever cable
2. Heat cover
3. Air filter



Front drum - Checking the oil level

Park the roller on a level surface, and drive the roller slowly until the oil plug (1) is in the middle of the semicircle shaped notch in the drum suspension.



Switch off the engine, disconnect the power and push in the reserve/parking brake knob.

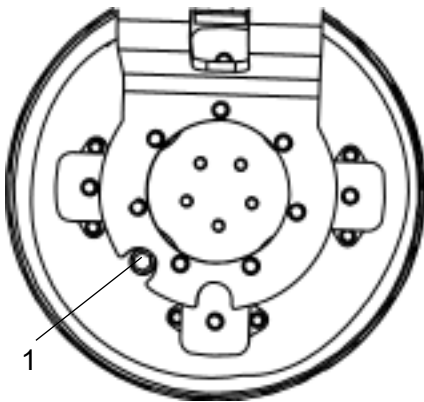

Figure. Front drum, drive side
1. Oil plug

Unscrew the plug and check that the oil level reaches the hole's lower edge. If necessary, top off with fresh transmission fluid. See under the heading lubricants for correct fluid grade.

Clean the magnetic oil plug (1) from any metallic residue, and refit the plug.



Hydraulic reservoir - Check/venting

Unscrew and make sure that the reservoir cap is not blocked. Air must have unobstructed passage through the cap in both directions.

If blocked in either direction, clean with a little diesel oil and blow with compressed air until unblocked or replace the cap with a new one.



Wear eye protectors and gloves when working with compressed air.

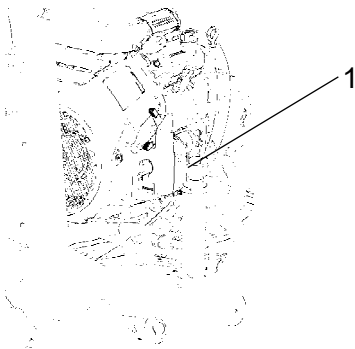

Figure. Engine compartment, right side
1. Hydraulic fluid tank cap

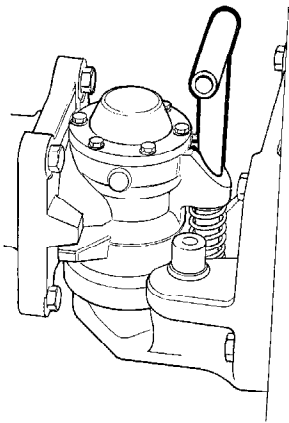

Fig. Steering joint

Steering joint - Check

Inspect the steering joint to detect any damage or cracks.

Check and tighten any loose bolts.

Check also for any stiffness and play in the steering joint. Rectify if necessary.

Air cleaner - replace insert

Pull the air cleaner cover latch (1) to the unlocked position and remove the cover (2).

Remove the wing nut (3) from the filter element (4).

Lift out the foam filter element (8) and the filter element (4).

Dry the inside of the filter container and its cover with a damp rag. Make sure that dirt does not enter the suction pipe.

Reinstall with new filter element and secure the cover with put the latch (1) to locked position.

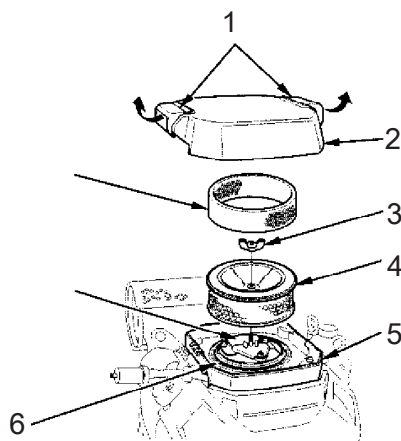

Fig. Air cleaner

1. Cover latch
2. Cover
3. Wing nut
4. Filter element
5. Case
6. Seal
7. Air chamber
8. Foam filter element



Hydraulic fluid filter - Change



Remove the filter (1) and deliver to special waste handling. This is a single-use filter and cannot be cleaned.

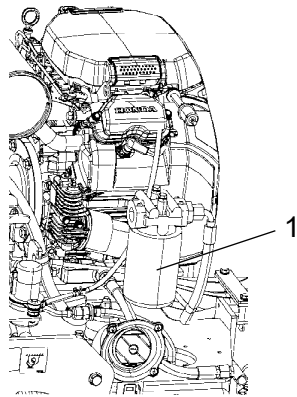

Fig. Engine compartment, left side
1. Hydraulic fluid filter

Thoroughly clean the filter holder sealing surface.

Apply a thin coat of fresh hydraulic fluid to the rubber gasket on the new filter.

Screw the filter on by hand, firstly until the filter gasket makes contact with the filter base. Then rotate a further ½ turn.



Do not over-tighten. The seal can be damaged.

Start the engine and check that the filter does not leak.



Engine oil and oil filter - Change

Run the engine until it is warm before draining the oil.



Switch off the engine and push in the reserve/parking brake knob.



Take great care when draining fluids and oils. Wear protective gloves and goggles.

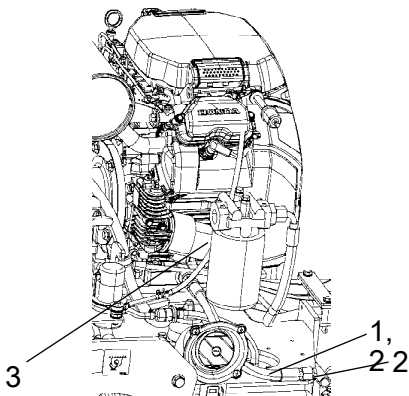

Fig. Engine compartment, left side
1. Drain hose
2. Plug
3. Oil filter

Place a receptacle that holds at least 4 liters (1 gal.) under the drain plug (2).

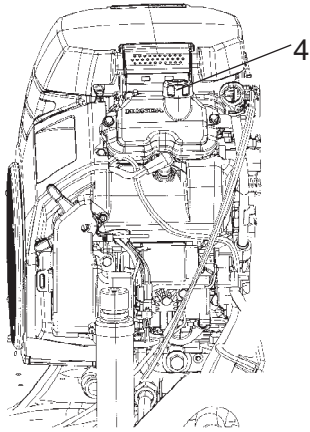

Fig. Engine compartment, right side
4. Filler cap

Undo the oil filler cap (4) and remove the plug (2) from the end of the drain hose (1); allow all the engine oil to run out.



Deliver the drained oil to special waste handling.



Refer to the engine manual for detailed instructions when changing oil and filters.

Remove the oil filter (3) and insert a new one.

Collect any spillage.

Fit the drain plug (2) to the end of the hose.

Fill with fresh engine oil (see under Lubricants heading for the correct oil grade), refit the filler cap (4) and check the level on the dipstick.

Start the engine and check the tightness around the oil filter.

Maintenance - 2000h

 **Park the roller on a level surface. When checking and making adjustments, the engine should be switched off and the emergency/parking brake should be applied, if not otherwise specified.**

 **Check that the engine cover is fully open before carrying out work underneath it.**



Spark plug - Replace

 **Switch off the engine and push in the reserve/parking brake knob.**

 **Observe care with hot surfaces. Wear gloves.**

 **Refer to the engine manual for detailed instructions.**

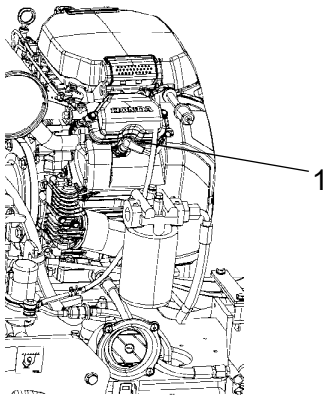

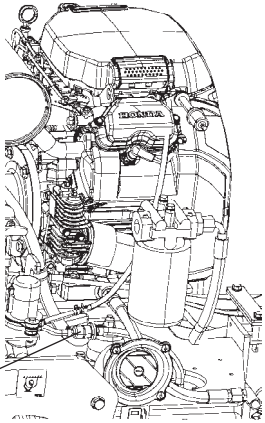

Fig. Engine compartment left side
1. Location of the spark plug on the left and right sides of the engine.

 **Dispose of used spark plugs properly.**



Engine's fuel filter - Replace



**Fig. Engine compartment left side
1. Fuel filter**



Switch off the engine and push in the reserve/parking brake knob.



Use caution. Wear gloves.

Replace the fuel filter (1).



Refer to the engine manual for detailed instructions.



Dispose of the old filter carefully.

Hydraulic fluid cooler - Cleaning (Option)

Clean the hydraulic fluid cooler's cooling flanges, ideally with compressed air. Blow the cooler clean by blowing air from the inside outwards.



Wear gloves and eye protectors when working with compressed air.



Forward/Reverse controls and joints - Check and lubrication

Unscrew the protective plate. Check the friction on the forward/reverse lever. The friction nut (1) should be applied with sufficient pressure to keep the forward/reverse lever in the set position during operation.

If the lever gets stiff after prolonged use, lubricate the lever at the bearing bushings and at the cable with a few drops of oil at each place.

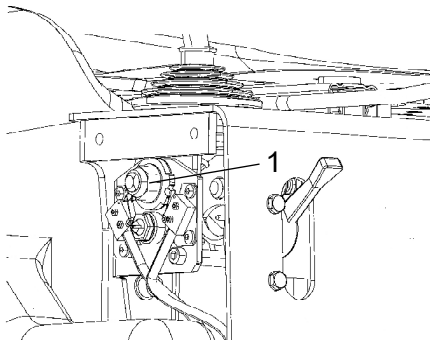

Figure. Forward/reverse lever
1. Friction nut

If the forward/reverse lever still is stiff after the above adjustments, lubricate the other end of the control cable with a few drops of oil. The cable is located on the top of the propulsion pump.

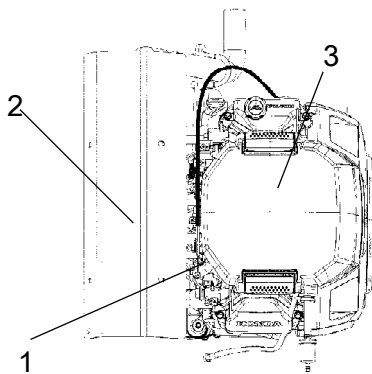

Fig. Engine compartment
1. F/R lever cable
2. Heat cover
3. Air filter



Hydraulic reservoir - Check/venting

Unscrew and make sure that the reservoir cap is not blocked. Air must have unobstructed passage through the cap in both directions.

If blocked in either direction, clean with a little diesel oil and blow with compressed air until unblocked or replace the cap with a new one.



Wear eye protectors and gloves when working with compressed air.

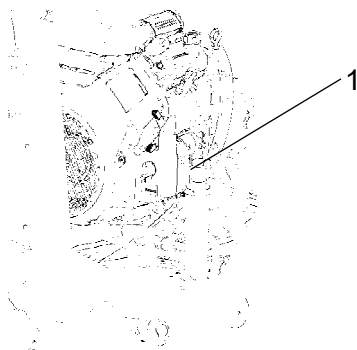

Figure. Engine compartment, right side
1. Hydraulic fluid tank cap

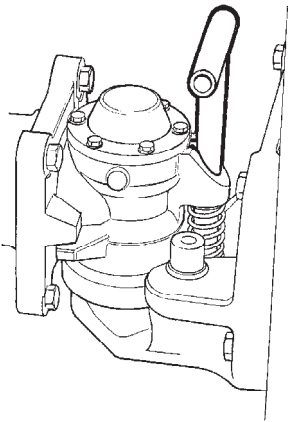

Fig. Steering joint

Steering joint - Check

Inspect the steering joint to detect any damage or cracks.

Check and tighten any loose bolts.

Check also for any stiffness and play in the steering joint. Rectify if necessary.

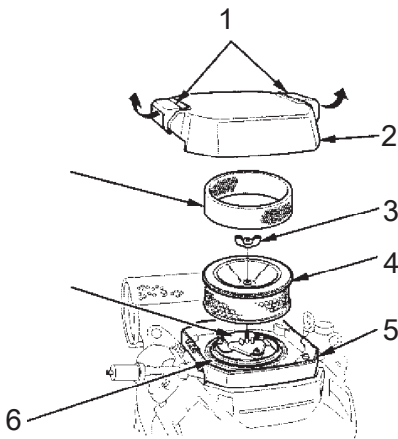

Fig. Air cleaner

1. Cover latch
2. Cover
3. Wing nut
4. Filter element
5. Case
6. Seal
7. Air chamber
8. Foam filter element

Air cleaner - replace insert

Pull the air cleaner cover latch (1) to the unlocked position and remove the cover (2).

Remove the wing nut (3) from the filter element (4).

Lift out the foam filter element (8) and the filter element (4).

Dry the inside of the filter container and its cover with a damp rag. Make sure that dirt does not enter the suction pipe.

Reinstall with new filter element and secure the cover with the latch (1) to locked position.



Hydraulic fluid filter - Change



Remove the filter (1) and deliver to special waste handling. This is a single-use filter and cannot be cleaned.

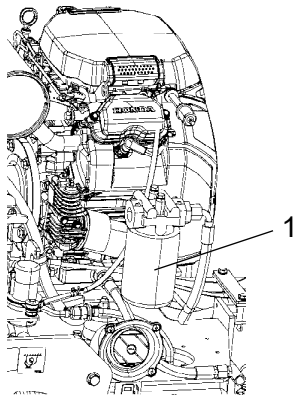

Fig. Engine compartment, left side
1. Hydraulic fluid filter

Thoroughly clean the filter holder sealing surface.

Apply a thin coat of fresh hydraulic fluid to the rubber gasket on the new filter.

Screw the filter on by hand, firstly until the filter gasket makes contact with the filter base. Then rotate a further ½ turn.



Do not over-tighten. The seal can be damaged.

Start the engine and check that the filter does not leak.



Engine oil and oil filter - Change

Run the engine until it is warm before draining the oil.



Switch off the engine and push in the reserve/parking brake knob.



Take great care when draining fluids and oils. Wear protective gloves and goggles.

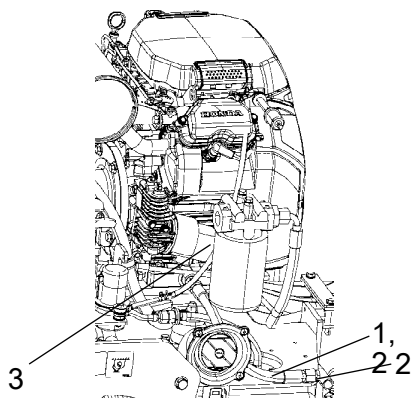

Fig. Engine compartment, left side
1. Drain hose
2. Plug
3. Oil filter

Place a receptacle that holds at least 4 liters (1 gal.) under the drain plug (2).

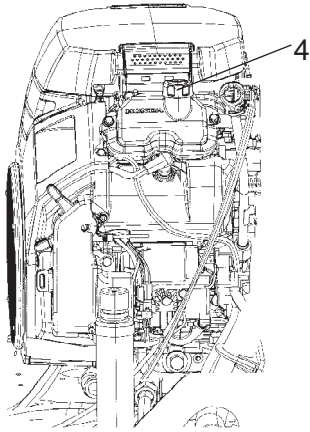

Fig. Engine compartment, right side
4. Filler cap

Undo the oil filler cap (4) and remove the plug (2) from the end of the drain hose (1); allow all the engine oil to run out.



Deliver the drained oil to special waste handling.



Refer to the engine manual for detailed instructions when changing oil and filters.

Remove the oil filter (3) and insert a new one.

Collect any spillage.

Fit the drain plug (2) to the end of the hose.

Fill with fresh engine oil (see under Lubricants heading for the correct oil grade), refit the filler cap (4) and check the level on the dipstick.

Start the engine and check the tightness around the oil filter.



Hydraulic reservoir - fluid change

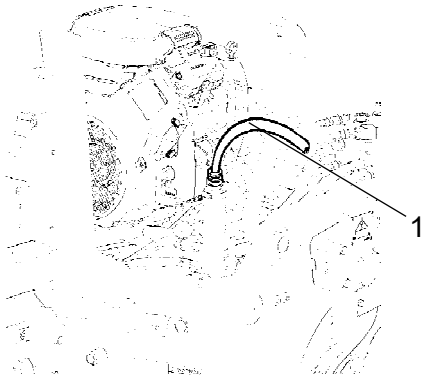

Fig. Hydraulic reservoir
1. Draining

Use an external drainage pump when draining/emptying the hydraulic reservoir.



Danger of being burned when draining hot oil.
Wear gloves and eye protectors.

Unscrew the reservoir cap. Use an external pump and check that the pump's hose reaches the bottom of the hydraulic reservoir in order to remove as much of the oil as possible. Drain the hydraulic oil into a drainage container.



Use a receptacle that holds at least 15 liters (4 gal).



Collect the oil and deliver to special waste handling.

Change the hydraulic fluid filter, see under heading 'Every 900 hours of operation'.

Fill with fresh hydraulic fluid (see under Lubricants heading for the correct grade), refit the filler cap, and check the level in the tank.

Wipe up any spillage.

Start the engine and operate the various hydraulic functions. Check the level in the reservoir and top off as required.



Front drum - Changing the oil

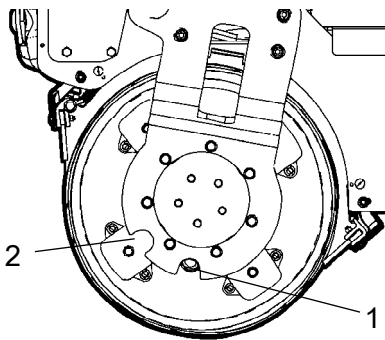



Fig. Drum, Drive side
 1. Oil plug
 2. Position for level check

Loosen the oil plug (1) slightly, when it is in position for level check (2), so that it can subsequently be unscrewed by hand.

Park the roller on a level surface, and drive the roller slowly until the plug (1) is in the bottom position.

 **Switch off the engine, disconnect the power and push in the reserve/parking brake knob.**

Place a receptacle that will hold at least 4 liters (1 gal) under the plug.

Remove the plug (1) and let the oil run out.

 Deliver the drained oil to special waste handling.

See under the section 'Every 500 hours of operation' for filling oil.



Water tank - Cleaning

 Keep in mind that there is a risk of freezing in winter. Drain the tank, pump and lines.

Empty the tank.

Clean the tank with water and a suitable detergent for plastic surfaces.

Fill the tank with water and check that the sprinkler works.

 The water tank is made of plastic (polyethylene) and is recyclable.

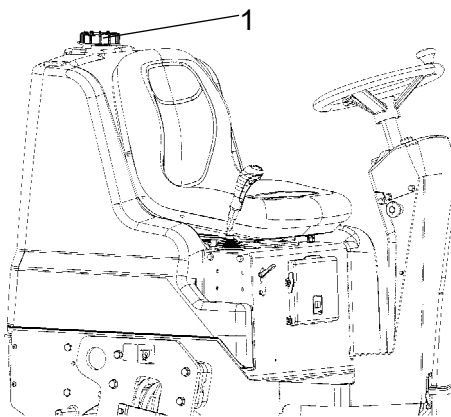

Fig. Water tank
 1. Cap